

Resource Manual

For Design & Construction Professionals



PREMIER SIPS
STRUCTURAL INSULATED PANELS

Faster. Stronger. Greener.

TABLE OF CONTENTS

Section 1: Design Resources

Structural Review DR-1
R-values & U-Factors..... DR-2
SIPS Weight..... DR-2
Spline Basics..... DR-3
Load Charts.....DR-4
Accessories: Screws, Sealant,
Tape, Building Wrap & Tools..... DR-23

Section 2: Contractor Resources

A. Ordering & Production Process

The Premier Ordering Process.....CR-2
Detailed Premier Project LifecycleCR-3
Guide For Reviewing Layout Drawings....CR-8
Premier SIPS Layout Drawings
Review Checklist.....CR-10

B. Installation Guidelines

5 Steps To Take Prior To SIP
System Delivery..... CR-11
Recommended SIPS Installation Tools..... CR-11
Quick SIPS Jobsite Installation
Best Practices..... CR-12
SIPS Delivery Preparation CR-13
Detailed Installation Recommendations.... CR-14

Section 3: Technical Bulletins

Building Code TB-2
Testing..... TB-7
Design..... TB-22
Electrical.....TB-58
Fire TB-60
Air Quality – HVAC.....TB-62
Installation.....TB-67
Moisture..... TB-76
Roof Specific TB-84
Wall Specific.....TB-98

Section 4: Construction Details

Premier 100 Series: General Details..... CD-4
Premier 200 Series: Spline Details.....CD-24
Premier 300 Series: Foundation Details...CD-34
Premier 400 Series: Wall DetailsCD-45
Premier 500 Series:
Wall to Roof Connection..... CD-60
Premier 600 Series:
Roof Bearing Details CD-75
Premier 700 Series: Roof DetailsCD-81
Premier 800 Series: Floor Details.....CD-96





INTRODUCTION

Premier Building Systems (Premier) is North America's largest manufacturer of Structural Insulated Panel Systems (SIPS). Premier has been involved in the manufacturing of Premier SIPS for more than 50 years. In fact, the same family who owns and operates Premier was instrumental in the IRC's approval of Structural Insulated Panels (SIPS) in the 1970's.

This Resource Manual covers the critical elements for Design Professionals and Contractors when using Premier SIPS to frame roofs, walls, and floors for exceptionally high performance residential and commercial buildings. Including product testing for Premier SIPS loading criteria, R-values, design and construction details, product accessory information, jobsite best practices and much more.

Local codes, climates and practices will direct the designer or contractor in the application of ventilation, building wraps, vapor barriers, exterior finishes and thermal barriers, and Premier has many resources to aid you throughout the entire process.



A HISTORY OF THIRD PARTY MONITORED TESTING

Premier credits a reputation for quality to extensive testing that began in 1968. In 1997 we charted our widest course yet by embarking on an industry leading comprehensive structural test program. These full-scale destructive tests, by independent code recognized laboratories, have allowed Premier to achieve some of the highest load capacities of any SIPs products in the industry.



EXTENSIVE TESTING DELIVERS ACCURATE DATA

Premier's testing and analysis programs have produced an extensive and comprehensive amount of data that allows us to help design professionals optimize designs with respect to both structural and energy concerns. Arming yourself with this accurate data helps you streamline the design process and make informed, dependable decisions. Premier's proprietary data is based upon hard facts, derived from extensive independent testing agencies to obtain structural design capacities contained in our load charts. That's a benefit on which you rely on throughout the life of your project. *Note: Extrapolating design capacities for conditions outside the scope of the load charts is not recommended.*



UNPARALLELED SUPPORT

Along with Premier's engineers and technical division, the entire team strives to provide you with the most current information in this quickly changing marketplace. Look to Premier's project team to help early and often to ensure that your project starts smoothly and finishes strong.

Design Resources

Faster. Stronger. Greener.



Website: premiersips.com

Toll Free: 800-275-7086

Details, illustrations, pictures, and guidelines provided in this Resource Manual give basic information and illustrate examples of Premier SIPS design & installation recommendations. The basic information provided herein is not intended to cover every potential use and application of Premier SIPS. It is the responsibility of the owner and/or the owner's representative to design the insulated wall assembly to perform in a manner ensuring function and durability. Adding an additional insulation component may change the behavior of a wall assembly regarding air movement, water vapor transmittance, bulk water management, and heating, cooling, and ventilation systems. It is the responsibility of the installer to become familiar with each specific application and determine if Premier SIPS are suitable. By commencing work, the installer accepts full responsibility for the proper and safe installation of Premier SIPS at each job site. Furthermore, it is the sole responsibility of the installer to meet all federal and local regulatory requirements for job site safety for every person on the job site while in the execution of all phases of the SIP installation.

DESIGN RESOURCES: CONTENTS

R-values & U-Factors.....	DR-2
SIP Weights.....	DR-2
Spline & SIP Connection Basics.....	DR-3
Load Charts.....	DR-4
Screw & Fastener Properties.....	DR-19
Accessory Data Sheets (Screws, Sealant, Tape, Building Wrap).....	DR-24



PREMIER SIPS STRUCTURAL REVIEW

ARCHITECT/ENGINEERING REVIEW

The Premier SIPS Load Charts in this Resource Manual have been developed from national testing standards, testing at independent laboratories, and qualified structural engineers. These charts cover most common construction requirements. Each building project should be reviewed by an architect/engineer to determine the suitability of Premier SIPS. Extrapolating design capacities for conditions outside the scope of the load charts is not recommended.

BUILDING CODES

Premier SIPS are recognized and in compliance with the 2015, 2018 and 2021 International Building Code and 2015, 2018 and 2021 International Residential Code. Premier SIPS should be designed to comply with the deflection limits of the applicable building code.

EVALUATION REPORTS

The International Code Council Evaluation Service (ICC-ES) has reviewed the independent testing, structural engineering, third party inspections, and QC program for Premier SIPS and has issued Evaluation Report ESR-4524, Listing Report ESL-1207, and Listing Report ESL-1208.



All current Code Reports can be accessed at www.premiersips.com.

PREMIER SIPS R-VALUES & U-FACTORS

SIP R-VALUES						
SIP Thickness	R-value at 75 ° F		R-value at 40 ° F		R-value at 25 ° F	
	EPS Core	GPS Core	EPS Core	GPS Core	EPS Core	GPS Core
4-1/2"	15	18	16	19	17	20
6-1/2"	23	28	24	29	26	30
8-1/4"	30	36	32	37	33	39
10-1/4"	37	45	40	47	42	49
12-1/4"	45	55	48	57	51	59

SIP U-FACTORS						
SIP Thickness	U-factor at 75 ° F		U-factor at 40 ° F		U-factor at 25 ° F	
	EPS Core	GPS Core	EPS Core	GPS Core	EPS Core	GPS Core
4-1/2"	0.066	0.055	0.062	0.052	0.058	0.050
6-1/2"	0.043	0.035	0.041	0.034	0.038	0.033
8-1/4"	0.033	0.027	0.031	0.027	0.030	0.025
10-1/4"	0.027	0.022	0.025	0.021	0.023	0.020
12-1/4"	0.022	0.018	0.020	0.017	0.019	0.016

NOTE: See Detail Premier-102 and Technical Bulletins for additional R-value & U-Factor considerations. Both are available at www.premiersips.com.

PREMIER SIPS WEIGHT

SIP WEIGHT			
SIP Thickness	OSB Facing Thickness (Both Faces)		
	7/16"	5/8"	3/4"
4-1/2"	3.3	4.6	5.5
6-1/2"	3.5	4.8	5.7
8-1/4"	3.7	5.0	5.9
10-1/4"	3.9	5.2	6.1
12-1/4"	4.0	5.4	6.2

Premier SIPS are typically manufactured with 7/16" OSB facings on both sides. Custom 5/8" or 3/4" OSB facings are available as an alternative. Substitution of one or both 7/16" OSB facings will add 0.65 psf per facing for 5/8" OSB and 1.1 psf per facing for 3/4" OSB. Consult your Premier Representative for additional Code Approved facing options.



PREMIER SIPS SPLINE BASICS

Premier SIPS are connected by splines.

There are three basic types of spline connections:

- Type S
- Type I
- Type L

SPLINE CONSIDERATIONS FOR DESIGN PROFESSIONALS:

- If splines are simply acting as a connection between panels, the “Type S” spline meets this requirement while eliminating thermal bridging.
- If the purpose of the spline is also to provide additional structural support, “Type I” or “Type L” splines can be used.
- Determination of proper spline for each application can be found by referring to the Premier SIPS Load Charts.
- Contractors should refer to SIP Layout Drawings for proper spline installation.

TYPE S SPLINE

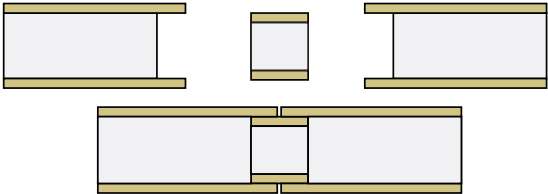

TYPE I SPLINE

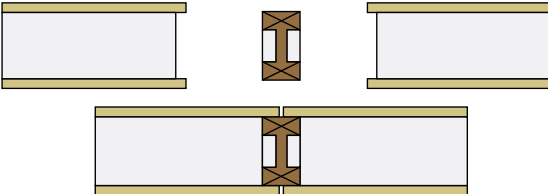

TYPE L SPLINE

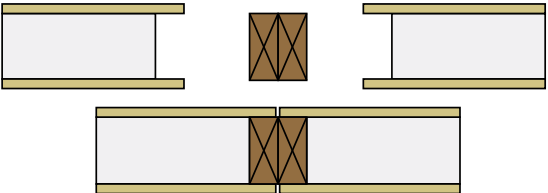

PREMIER SIPS LOAD CHARTS

LOAD CHART CONTENTS

Load Chart #1A - Uniform Axial Loads - Type S Spline DR-5

Load Chart #1B - Uniform Axial Loads - Type L Spline DR-6

Load Chart #2A - Axial Point Loads..... DR-7

Load Chart #3A - Wall Uniform Transverse Loads..... DR-8

Load Chart #3B - Curtain Wall Uniform Transverse Loads..... DR-9

Load Chart #4A - Shear Loads - Seismic Design Categories A-C DR-10

Load Chart #4B - Shear Loads - Seismic Design Categories A-F..... DR-11

Load Chart #5A - Header: SIP Header Uniform Loads..... DR-12

Load Chart #5B - Header: Premier 1 PLY Insulated Header Beams Uniform Loads... DR-13

Load Chart #5C - Header: Premier 2 PLY Insulated Header Beams Uniform Loads... DR-14

Load Chart #6A - Roof/Floor Uniform Transverse Loads - Type S Spline DR-15

Load Chart #6B - Roof/Floor Uniform Transverse Loads - Type I Spline..... DR-16

Load Chart #6C - Roof/Floor Uniform Transverse Loads - Type L Spline..... DR-17

Load Chart #7A - Roof/Floor Diaphragms Loads - Type S Spline..... DR-18



LOAD CHART #1A
Uniform Axial Loads - PLF¹⁻⁴
Type S Spline

SIP Thickness	SIP Height (ft.)					
	8'	10'	12'	16	20'	24'
4-1/2"	3500	2553	2453	2117	NA	NA
6-1/2"	4250	4043	3373	3923	2817	2183
8-1/4"	4917	4327	4473	4197	3497	3067
10-1/4"	4600	4414	4228	4417	3389	3248
12-1/4"	3889	3959	4028	4408	3837	3333

¹ Permanent loads, such as dead load, shall not exceed 0.50 times the tabulated load.

² Uniform axial loads.

³ Both facings must bear on the supporting foundation or structure.

⁴ Tabulated values for 8-foot (2.44 m) walls apply to SIPs constructed with OSB strength axis oriented either parallel or perpendicular to supports.

AXIAL LOAD

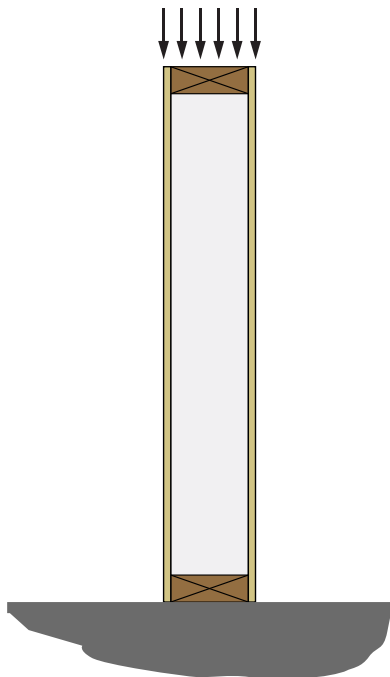

TYPE S SPLINE

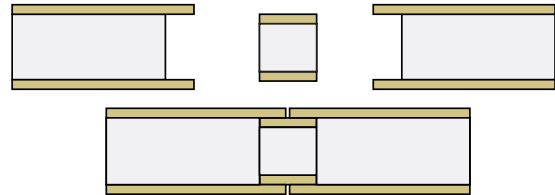

LOAD CHART #1B
Uniform Axial Loads - PLF¹⁻⁴
Type L Spline

SIP Thickness	SIP Height (ft.)					
	8'	10'	12'	16'	20'	24'
4-1/2"	4723	3903	3273	2623	NA	NA
6-1/2"	5850	5890	4277	4310	2933	2837
8-1/4"	6807	6110	5557	5180	4837	4083
10-1/4"	5473	5709	5946	5948	4729	4250
12-1/4"	5667	5474	5281	5775	4729	4223

¹ Splines consist of No. 2 or better, Hem-Fir, 1-1/2 inch (38.1 mm) wide with depth equal to the core thickness, spaced to provide no less than two members for every 48 inches (1219.2 mm) of SIPs width. Permanent loads, such as dead load, shall not exceed 0.50 times the tabulated load.

² Uniform axial loads.

³ Both facings must bear on the supporting foundation or structure.

⁴ Tabulated values for 8-foot (2.44 m) walls apply to SIPs constructed with OSB strength axis oriented either parallel or perpendicular to supports.

AXIAL LOAD

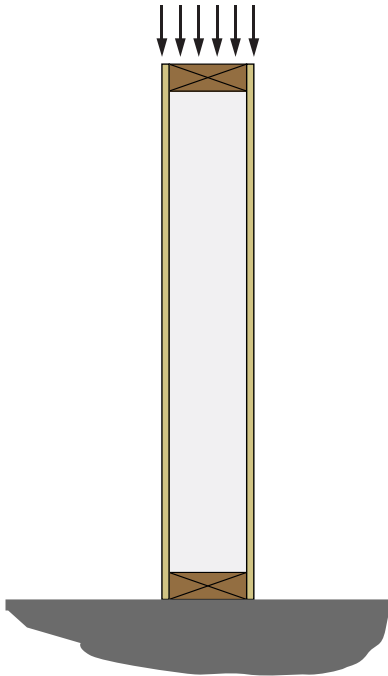

TYPE L SPLINE

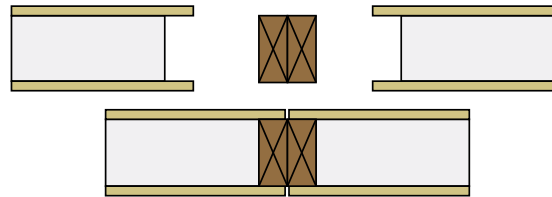

LOAD CHART #2A Axial Point Loads - LBS ¹⁻² Type S Spline		
Top Plate Configuration	1-1/2" BEARING WIDTH	3" BEARING WIDTH
Single 2x No. 2 or better Hem-Fir Plate	2040	2450
Single 2x No. 2 or better Hem-Fir Plate with 2x No. 2 or Better Cap Plate Ripped to Total Width of SIP.	4030	4678

¹ Permanent loads, such as dead load, shall not exceed 0.50 times the tabulated load.

² Tabulated values are based on the strong-axis of the facing material oriented parallel to the span direction.

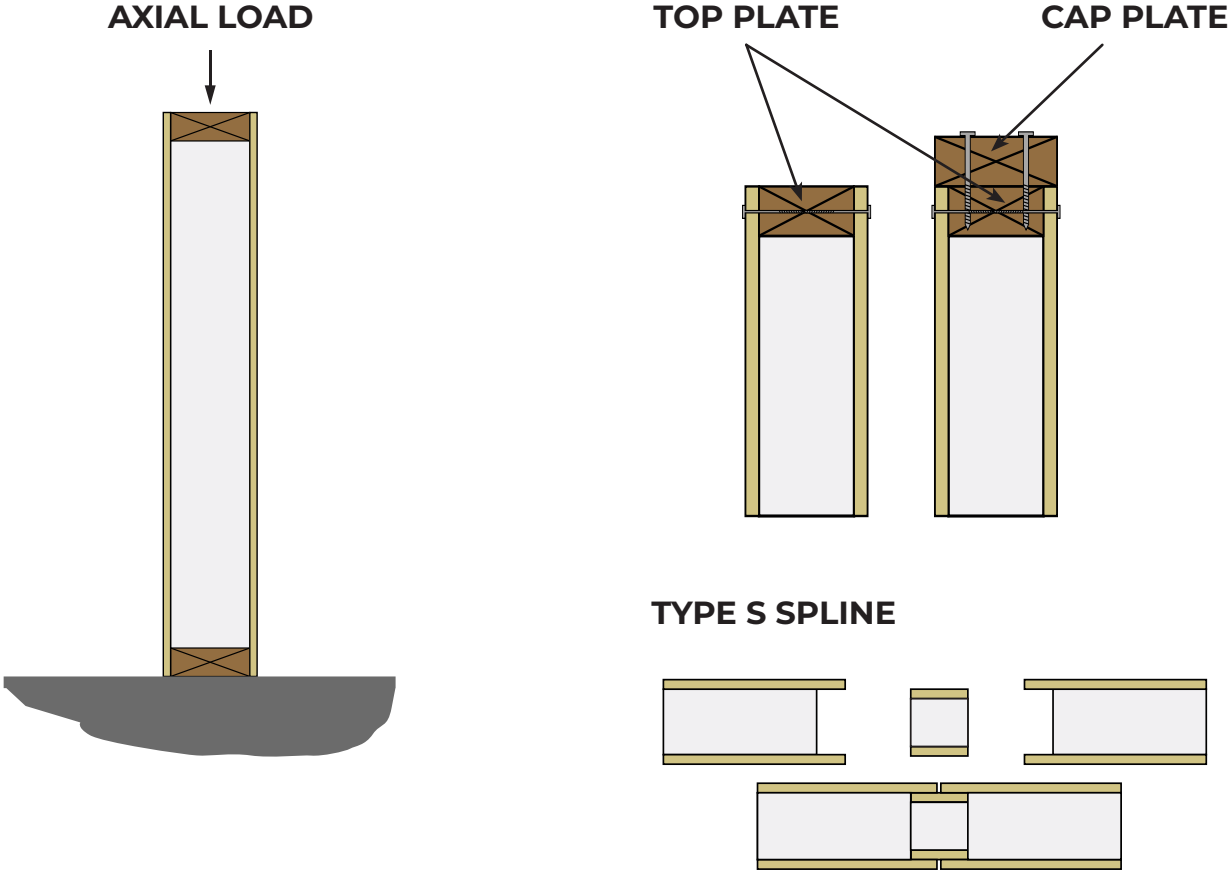

LOAD CHART #3A

Wall Uniform Transverse Loads - PSF ¹⁻³

Type S Spline

SIP Thickness	Deflection Limit	SIP Height (ft.)								
		8'	10'	12'	14'	16'	18'	20'	22'	24'
4-1/2"	L/360	32	23	18	14	11	NA	NA	NA	NA
	L/240	48	35	27	21	16	NA	NA	NA	NA
	L/180	55	44	36	28	22	NA	NA	NA	NA
6-1/2"	L/360	51	38	29	23	19	15	12	NA	NA
	L/240	67	53	44	35	28	23	19	NA	NA
	L/180	67	53	44	38	33	29	24	NA	NA
8-1/4"	L/360	67	51	40	32	26	22	18	15	13
	L/240	75	60	50	42	37	33	27	23	19
	L/180	75	60	50	42	37	33	30	26	22
10-1/4"	L/360	83	66	52	43	35	29	25	21	18
	L/240	83	66	55	47	41	36	33	30	27
	L/180	83	66	55	47	41	36	33	30	27
12-1/4"	L/360	89	72	60	51	44	37	32	27	23
	L/240	89	72	60	51	45	40	36	32	30
	L/180	89	72	60	51	45	40	36	32	30

¹ Permanent loads, such as dead load, shall not exceed 0.50 times the tabulated load.

² Deflection limit shall be selected by building designer based on the serviceability requirements of the structure and the requirements of applicable building code. Values are based on loads of short duration only.

³ Table values for 8-foot (2.44 m) spans apply to SIPs constructed with the OSB strength axis oriented either parallel or perpendicular to span direction. Table values for other spans are based on the OSB strength axis parallel to the span direction..

TRANSVERSE LOAD

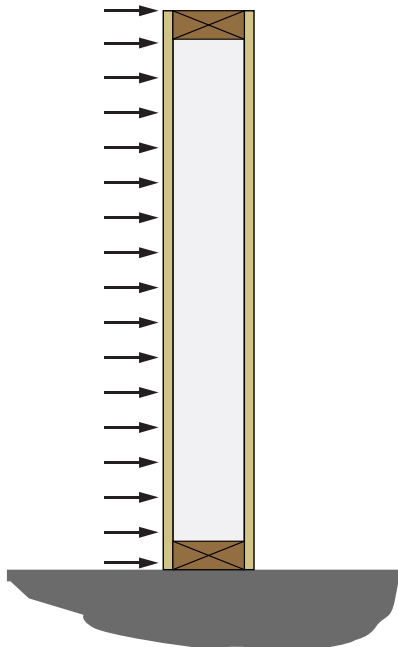

TYPE S SPLINE

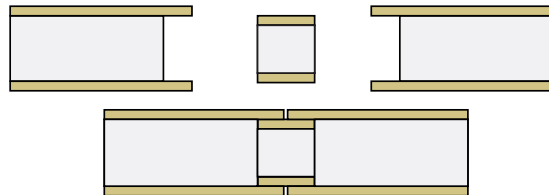

LOAD CHART #3B

Curtain Wall Uniform Transverse Loads - PSF ¹⁻³

Type S Spline

SIP Thickness	Deflection Limit	SIP Height (ft.)									
		4' ⁴	8'	10'	12'	14'	16'	18'	20'	22'	24'
4-1/2"	L/360	100	32	23	18	14	11	NA	NA	NA	NA
	L/240	143	48	35	27	21	16	NA	NA	NA	NA
	L/180	143	63	47	36	28	22	NA	NA	NA	NA
6-1/2"	L/360	105	51	38	29	23	19	15	12	NA	NA
	L/240	162	76	57	44	35	28	23	19	NA	NA
	L/180	191	80	61	50	42	36	30	24	NA	NA
8-1/4"	L/360	120	67	51	40	32	26	22	18	15	13
	L/240	179	94	71	57	48	40	33	27	23	19
	L/180	179	94	71	57	48	41	36	32	26	22
10-1/4"	L/360	131	86	66	52	43	35	29	25	21	18
	L/240	168	94	75	63	54	47	41	36	32	27
	L/180	168	94	75	63	54	47	41	36	33	28
12-1/4"	L/360	132	94	75	63	53	44	37	32	27	23
	L/240	163	94	75	63	54	47	42	37	34	31
	L/180	163	94	75	63	54	47	42	37	34	31

- ¹ Table values assume a simply supported SIP with 1-1/2 inches (38.1 mm) of continuous bearing. Permanent loads, such as dead load, shall not exceed 0.50 times the tabulated load. Values do not include the dead weight of the SIP.
- ² Deflection limit shall be selected by building designer based on the serviceability requirements of the structure and the requirements of applicable building code. Values are based on loads of short duration only and do not consider the effects of creep.
- ³ Table values for 8-foot (2.44 m) spans apply to SIPs constructed with the OSB strength axis oriented either parallel or perpendicular to span direction. Table values for other spans are based on the OSB strength axis parallel to the span direction.
- ⁴ SIPs shall be a minimum of 8-foot (2.44 m) long spanning two 4-foot (1.22 m) spans.

TRANSVERSE LOAD

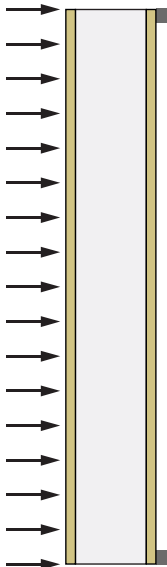

TYPE S SPLINE

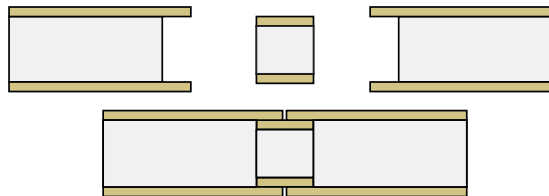

LOAD CHART #4A
Shear Loads - PLF¹⁻⁷ Seismic Design Categories A-C
Type S or Type L Spline

Framing Minimum SG	Minimum Facing Connections ⁴			Shear Load (PLF)
	Chord ^{4,5}	Plate	Spline	
0.50	0.113"x 2-1/2" nails 6" on center	0.113"x 2-1/2" nails 6" on center	(7/16" OSB Faced x 3" wide Box/Block Spline) 0.113"x 2-1/2" nails, 6" on center	410
0.50	0.113"x 2-3/8" nails 6" on center Staggered (2 rows)	0.113"x 2-3/8" nails 6" on center	(7/16" OSB Faced x 3" wide Box/Block Spline) 0.113"x 2-3/8" nails, 6" on center ⁶	460
0.42	0.113"x 2-3/8" nails 6" on center Staggered (2 rows)	0.113"x 2-3/8" nails 4" on center Staggered (2 rows)	(7/16" OSB Faced x 3" wide Box/Block Spline) 0.113"x 2-3/8" nails, 4" on center ⁶	700
0.42	0.148"x 2-3/8" nails 6" on center Staggered (2 rows)	0.148"x 2-3/8" nails 3" on center	(23/32" OSB Faced x 3" wide Box/Block Spline) 0.148"x 2-3/8" nails, 3" on center stagger (2 rows) ⁷	1000

¹ Wind and seismic loads in seismic design categories A, B, C.

² Aspect ratio (height:width) does not exceed 2:1.

³ Shear wall height-width ratios greater than 2:1, but not exceeding 3.5:1, are permitted for assemblies using lumber splines provided the allowable shear strength values in the table are multiplied by 2w/h.

⁴ Required connections must be made on each side of the SIPs. Dimensional or engineered lumber shall have an equivalent specific gravity not less than specified.

⁵ Chords, hold-downs and connections to other structural elements must be designed by a registered designer professional in accordance with accepted engineering practice.

⁶ 4 inch (101.6 mm) wide spline.

⁷ 4 inch (101.6 mm), 23/32 inch (18.25 mm) thick facing.

SHEAR LOAD

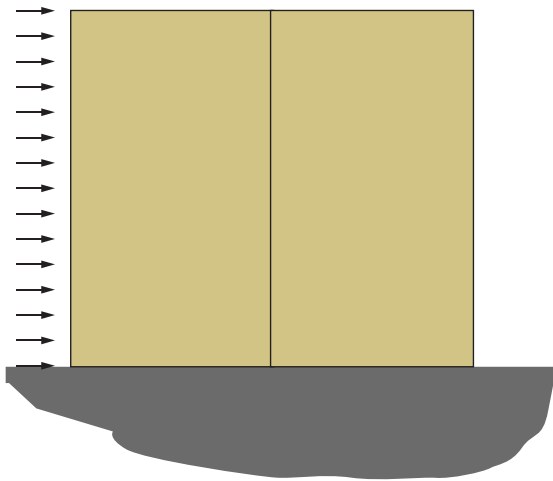

TYPE S SPLINE

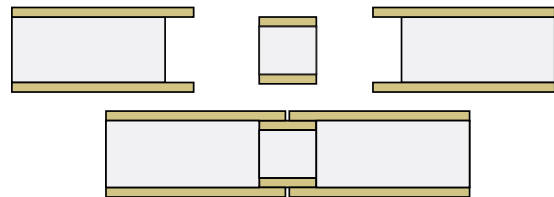

TYPE L SPLINE

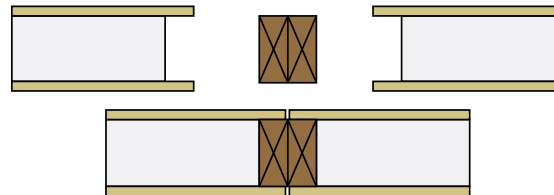

LOAD CHART #4B				
Shear Loads - PLF¹⁻⁷ Seismic Design Categories A-F • Type S or Type L Spline				
Framing Minimum SG ⁴	Minimum Facing Connections ⁴			Shear Load ²⁻³ (PLF)
	Chord ⁵	Plate	Spline ⁴	
0.50	0.113" x 2-1/4" nails, 6" on center	0.113" x 2-1/4" nails, 3" on center	(7/16" facing thickness, 3" wide Box/Block spline) 0.113" x 2-1/4" nails, 6" on center	360
0.50	0.113" x 2-1/4" nails, 6" on center	0.113" x 2-1/4" nails, 6" on center	(3/4" facing thickness, 3" wide Box/Block spline) 0.113" x 2-1/4" nails, 6" on center	360
0.50	0.113" x 2-3/8" nails, 3" on center staggered (3/8" edge distance and 3/4" edge distance)	0.113" x 2-3/8" round head nails, 3" on center staggered (3/8" and 3/4" edge distances)	(23/32" thick facing 3" wide Box/Block spline) 0.113" x 2-3/8" nails, 3" on center staggered (3/8" edge distance and 3/4" edge distance)	720
0.50	0.113" x 2-3/8" nails, 2" on center staggered (3/8" edge distance and 3/4" edge distance)	0.113" x 2-3/8" round head nails, 2" on center, staggered (3/8" and 3/4" edge distances)	(23/32" thick facing 3" wide Box/Block spline) 0.113" x 2-3/8" nails, 3" on center staggered (3/8" edge distance and 3/4" edge distance)	920

¹ Seismic loads in seismic design categories A, B, C, D, E and F. Walls shall be designed using the seismic design coefficients and limitations provided in ASCE 7-10 for light-framed walls sheathing with wood structural panels rated for shear resistance. SIP walls shall use the following factors for design: Response Modification Coefficient, R = 6.5; System Overstrength Factor, Ω_0 = 3.0; Deflection Amplification Factor, C_d = 4.0.

² Aspect ratio (height:width) does not exceed 1:1 for Type S spline or 2:1 for Type L spline.

³ Shear wall height-width ratios greater than 2:1, but not exceeding 3.5:1, are permitted for assemblies using lumber splines provided the allowable shear strength values in the table are multiplied by 2w/h.

⁴ Required connections must be made on each side of the SIP. Dimensional or engineered lumber shall have an equivalent specific gravity not less than specified in the table for the framing.

⁵ Chords, hold-downs and connections to other structural elements must be reviewed and approved by a registered design professional.

⁶ Solid chord members are required at each end of each shear wall segment. Dimensional double lumber splines must be interconnected using 10d common nails ([0.148-inch-diameter x 3 inches (3.8 mm x 76 mm)] spaced 5-inches (127 mm) on center.

⁷ 3 inch (76.2 mm) wide, 3/4 inch (19 mm) thick facing.

SHEAR LOAD

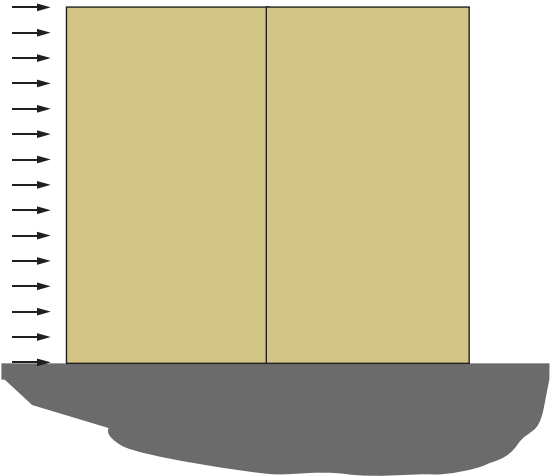

TYPE S SPLINE

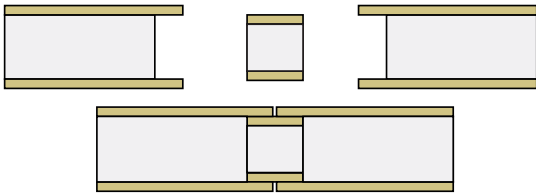

TYPE L SPLINE

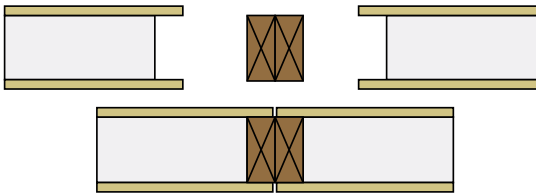

LOAD CHART #5A SIP Header Uniform Loads - PLF ¹⁻⁵						
Header Depth ³ (inches)	Header Spline ⁵	Deflection Limit ⁴	Header Span (ft.)			
			4'	6'	8'	10'
12"	NO	L/480	740	384	228	142
		L/360	740	384	229	142
		L/240	740	384	229	142
	YES ⁵	L/480	345	243	156	99
		L/360	450	295	190	125
		L/240	630	382	236	153
18"	NO	L/480	798	574	385	311
		L/360	798	574	385	311
		L/240	798	574	385	311
	YES ⁵	L/480	705	388	254	235
		L/360	750	482	302	281
		L/240	750	482	302	281
24"	NO	L/480	886	629	429	361
		L/360	886	629	429	361
		L/240	886	629	429	361
	YES ⁵	L/480	698	556	368	350
		L/360	896	556	368	350
		L/240	896	556	368	350

¹ Vertical loads only. Lateral loads shall be transferred to the edges of the openings through continuous plate(s) designed in accordance with accepted engineering practice. Permanent loads, such as dead load, shall not exceed 0.50 times the tabulated load.

² Tabulated values are based on the strong-axis of the facing material oriented perpendicular to the direction of the header span.

³ Minimum depth of facing above opening.

⁴ Deflection limit shall be selected by building designer based on the serviceability requirements of the structure and requirements of applicable building code.

⁵ SIP header may contain a spline a minimum of 6 inches from edge of opening.

HEADER LOAD

4-PIECE ASSEMBLY: NO HEADER SPLINE

Note: Engineer to review SIP header nailing

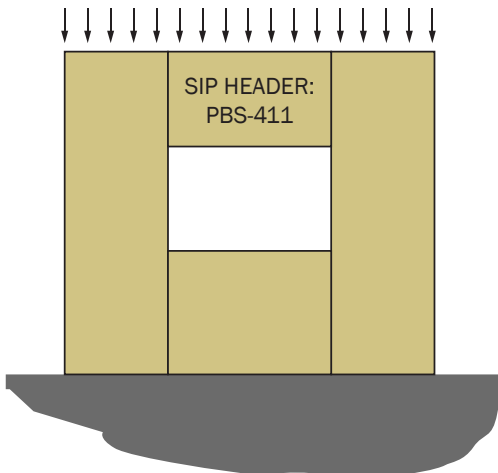

NO HEADER SPLINE

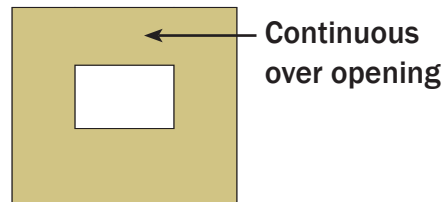

HEADER WITH SPLINE

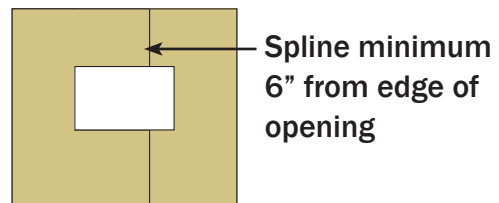

LOAD CHART #5B

Premier 1 PLY Insulated Header Beams Uniform Loads - PLF ¹

No. of Trimmer Studs	Deflection	Header Span (ft.)							
		2'	3'	4'	5'	6'	7'	8'	
1	L/480	1968	1312	984	787	656	562	492	
	L/360	1968	1312	984	787	656	562	492	
	L/240	1968	1312	984	787	656	562	492	
2	L/480	3937	2625	1968	1575	1312	1125	901	
	L/360	3937	2625	1968	1575	1312	1125	984	
	L/240	3937	2625	1968	1575	1312	1125	984	
No. of Trimmer Studs	Deflection	Header Span (ft.)							
		9'	10'	11'	12'	13'	14'	15'	16'
1	L/480	437	393	346	267	210	168	136	112
	L/360	437	393	357	328	280	224	182	150
	L/240	437	393	357	328	302	281	262	225
2	L/480	632	461	346	267	210	168	136	112
	L/360	843	615	462	356	280	224	182	150
	L/240	875	769	635	534	420	336	273	225

¹ Values listed for each deflection represent the least value of the bearing capacity of the trimmer, shear or beading capacity of the header or the actual deflection at the design load. Trimmer stud design capacities must be reviewed. LVL denotes 1-3/4" x 11-1/4" 2.0E RedLam material where E = 2,000,000 psi, Fb = 3,125 psi, Fv = 285 psi, and Fc-perp = 750 psi. Duration factors have not been applied to these capacities. The effects of long-term loading have not been included.

1 PLY HEADER

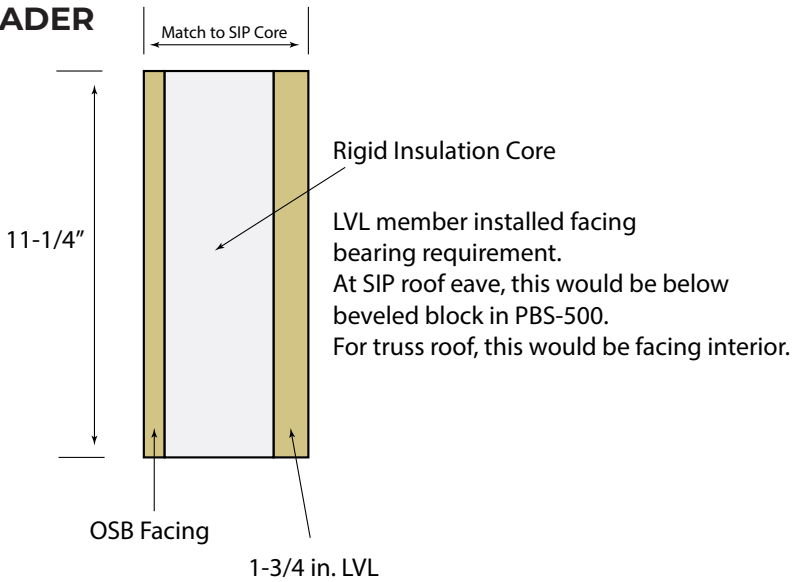

LOAD CHART #5C

Premier 2 PLY Insulated Header Beams Uniform Loads - PLF ¹

No. of Trimmer Studs	Deflection	Header Span (ft.)							
		2'	3'	4'	5'	6'	7'	8'	
1	L/480	3937	2625	1968	1575	1312	1125	984	
	L/360	3937	2625	1968	1575	1312	1125	984	
	L/240	3937	2625	1968	1575	1312	1125	984	
2	L/480	7875	5250	3937	3150	2625	2250	1802	
	L/360	7875	5250	3937	3150	2625	2250	1968	
	L/240	7875	5250	3937	3150	2625	2250	1968	
No. of Trimmer Studs	Deflection	Header Span (ft)							
		9'	10'	11'	12'	13'	14'	15'	16'
1	L/480	875	787	693	534	420	336	273	225
	L/360	875	787	715	656	560	446	364	300
	L/240	875	787	715	656	650	562	525	450
2	L/480	1265	922	693	534	420	336	273	225
	L/360	1687	1230	924	712	560	448	364	300
	L/240	1750	1538	1271	1068	840	672	546	450

¹ Values listed for each deflection represent the least value of the bearing capacity of the trimmer, shear or beading capacity of the header or the actual deflection at the design load. Trimmer stud design capacities must be reviewed. LVL denotes 1-3/4" x 11-1/4" 2.0E RedLam material where E = 2,000,000 psi, Fb = 3,125 psi, Fv = 285 psi and Fc-perp = 750 psi. Duration factors have not been applied to these capacities. The effect of long-term loading have not been included.

2 PLY HEADER

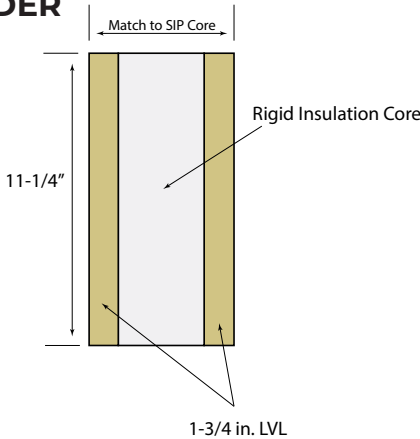

LOAD CHART #6A
Roof/Floor Uniform Transverse Loads - PSF¹⁻⁴
Type S Spline

SIP Thickness	Deflection Limit	SIP Span (ft.)									
		4' ⁴	8'	10'	12'	14'	16'	18'	20'	22'	24'
4-1/2"	L/360	100	32	23	NA	NA	NA	NA	NA	NA	NA
	L/240	143	48	35	NA	NA	NA	NA	NA	NA	NA
	L/180	143	63	47	NA	NA	NA	NA	NA	NA	NA
6-1/2"	L/360	105	51	38	29	23	NA	NA	NA	NA	NA
	L/240	162	76	57	44	35	NA	NA	NA	NA	NA
	L/180	191	80	61	50	42	NA	NA	NA	NA	NA
8-1/4"	L/360	120	67	51	40	32	26	22	NA	NA	NA
	L/240	179	94	71	57	48	40	33	NA	NA	NA
	L/180	179	94	71	57	48	41	36	NA	NA	NA
10-1/4"	L/360	131	86	66	52	43	35	29	25	21	NA
	L/240	168	94	75	63	54	47	41	36	32	NA
	L/180	168	94	75	63	54	47	41	36	33	NA
12-1/4"	L/360	132	94	75	63	53	44	37	32	27	23
	L/240	163	94	75	63	54	47	42	37	34	31
	L/180	163	94	75	63	54	47	42	37	34	31

- ¹ Table values assume a simply supported SIP with 1-1/2 inches (38.1 mm) of continuous bearing. Permanent loads, such as dead load, shall not exceed 0.50 times the tabulated load. Values do not include the dead weight of the SIP.
- ² Deflection limit shall be selected by building designer based on the serviceability requirements of the structure and the requirements of applicable building code. Values are based on loads of short duration only and do not consider the effects of creep.
- ³ Table values for 8-foot (2.44 m) spans apply to SIPs constructed with the OSB strength axis oriented either parallel or perpendicular to span direction. Table values for other spans are based on the OSB strength axis parallel to the span direction.
- ⁴ SIPs shall be a minimum of 8-foot (2.44 m) long spanning two 4-foot (1.22 m) spans.

TRANSVERSE LOAD

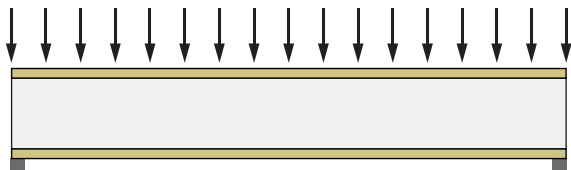

TYPE S SPLINE

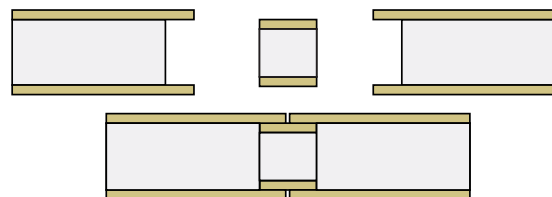

LOAD CHART #6B
Roof/Floor Uniform Transverse Loads - PSF¹⁻⁴
Type I Spline

SIP Thickness	Deflection Limit	SIP Span (feet)									
		4 ⁴	8	10	12	14	16	18	20	22	24
10-1/4"	L/360	197	164	124	72	67	61	48	34	29	24
	L/240	336	164	124	107	96	84	70	49	43	36
	L/180	336	164	124	107	96	84	76	65	56	47
12-1/4"	L/360	258	143	103	86	83	77	61	42	37	32
	L/240	318	143	103	93	85	77	68	59	54	46
	L/180	318	143	103	93	85	77	68	59	54	49

¹ Table values assume a simply supported SIP with 1-1/2 inches (38.1 mm) of continuous bearing. Permanent loads, such as dead load, shall not exceed 0.50 times the tabulated load. Splines consist of Premier I-beam, 2-1/4 inch (57.2 mm) wide flange (minimum) with a depth equal to the core thickness, spaced not to exceed 48 inches (1219.2 mm) on center.

² Deflection limit shall be selected by building designer based on the serviceability requirements of the structure and the requirements of applicable building code.

³ Table values for 8-foot (2.44 m) spans apply to SIPs constructed with the OSB strength axis oriented either parallel or perpendicular to span direction. Table values for other spans are based on the OSB strength axis parallel to the span direction.

⁴ SIP shall be a minimum of 8 foot (2.44 m) long spanning a minimum of two 4-foot (1.22 m) spans.

TRANSVERSE LOAD

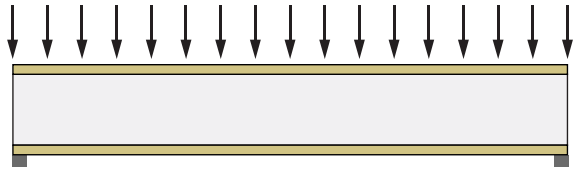

TYPE I SPLINE

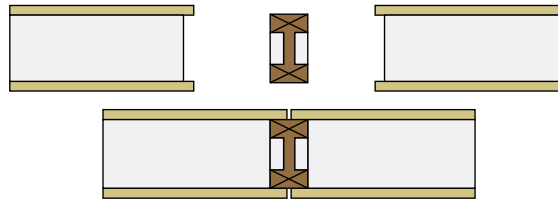

LOAD CHART #6C
Roof/Floor Uniform Transverse Loads - PSF¹⁻⁴
Type L Spline

SIP Thickness	Deflection Limit	SIP Span (feet)									
		4 ⁴	8	10	12	14	16	18	20	22	24
4-1/2"	L/360	103	45	33	24	NA	NA	NA	NA	NA	NA
	L/240	225	68	47	34	NA	NA	NA	NA	NA	NA
	L/180	297	91	61	45	NA	NA	NA	NA	NA	NA
6-1/2"	L/360	307	129	57	42	34	25	20	NA	NA	NA
	L/240	307	182	87	61	49	37	30	NA	NA	NA
	L/180	307	182	112	80	65	49	39	NA	NA	NA
8-1/4"	L/360	253	171	82	66	54	41	32	23	NA	NA
	L/240	288	188	128	100	81	61	48	35	NA	NA
	L/180	288	188	133	117	105	80	63	45	NA	NA
10-1/4"	L/360	286	188	117	101	80	58	47	36	32	27
	L/240	326	188	147	134	120	90	71	52	47	41
	L/180	326	188	147	134	121	106	93	68	61	53
12-1/4"	L/360	327	188	167	141	116	91	75	58	47	36
	L/240	327	188	167	153	132	110	97	83	69	53
	L/180	327	188	167	153	132	110	97	83	83	70

- ¹ Table values assume a simply supported SIP with 1-1/2 inches (38.1 mm) of continuous bearing. Permanent loads, such as dead load, shall not exceed 0.50 times the tabulated load. Splines consist of No. 2 or better Hem-Fir, 1-1/2 inches (38.1 mm) wide with a depth equal to the core thickness, spaced to provide not less than two members for every 48 inches (1219.2 mm) of SIP width.
- ² Deflection limit shall be selected by building designer based on the serviceability requirements of the structure and the requirements of applicable building code.
- ³ Table values for 8-foot (2.44 m) spans apply to SIPs constructed with the OSB strength axis oriented either parallel or perpendicular to span direction. Table values for other spans are based on the OSB strength axis parallel to the span direction.
- ⁴ SIP shall be a minimum of 8 foot (2.44 m) long spanning two 4-foot (1.22 m) spans. No single span condition is allowed.

TRANSVERSE LOAD

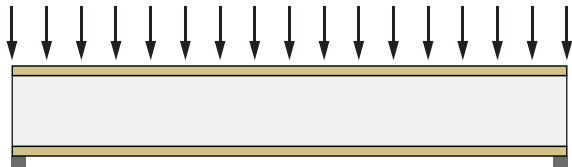

TYPE L SPLINE

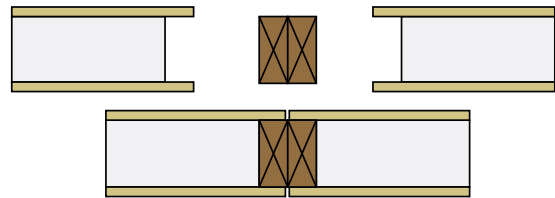

LOAD CHART #7A

Roof/Floor Diaphragms Loads - PLF ^{1, 5} • Type S Spline

Minimum Connections ²				Allowable Shear Load (PLF)	G' Apparent Shear Stiffness (lbf/in)	Maximum Aspect Ratio
Interior Supports ²	Spline ³	Boundary ⁴				
		Support	Spline			
PBS No. 14 SIP Screw with 1" penetration 12" on center	0.113" x 2-1/2" nails, 3" on center 7/16" x 3" OSB Box/Block Spline	PBS No. 14 SIP Screw with 1" penetration 12" on center	0.113" x 2-1/2" nails, 6" on center	430	24000	4:1
PBS No. 14 SIP Screw with 1" penetration 12" on center	0.113" x 2-1/2" nails, 3" on center, 2 rows, staggered 7/16" x 3" OSB Box/Block Spline	PBS No. 14 SIP Screw with 1" penetration 3" on center	0.113" x 2-1/2" nails, 4" on center	460	30300	4:1
PBS No. 14 SIP Screw with 1" penetration 2" on center	0.113" x 2-1/2" nails, 3" on center, 2 rows, staggered 7/16" x 3" OSB Box/Block Spline	PBS No. 14 SIP Screw with 1" penetration 2" on center	0.113" x 2-1/2" nails, 1-1/2" on center	655	41300	4:1
PBS No. 14 SIP Screw with 1" penetration 4" on center	0.113" x 2-1/2" nails, 3" on center, 2 rows, staggered 7/16" x 3" OSB Box/Block Spline	PBS No. 14 SIP Screw with 1" penetration 4" on center	0.113" x 2-1/2" nails, 3" on center	795	93700	3:1
PBS No. 14 SIP Screw with 1" penetration 4" on center	0.113" x 2-1/2" nails, 6" on center, 2 rows, staggered 23/32" x 4" OSB Box/Block Spline	PBS No. 14 SIP Screw with 1" penetration 4" on center	0.113" x 2-1/2" nails, 6" on center	1130	110600	3:1

- ¹ The maximum diaphragm length-to-width ratio shall not exceed 4: 1. Load may be applied parallel to continuous panel joints.
- ² Interior supports shall be spaced not to exceed 12 feet (3.66 m) on center and have a minimum width of 3-1/2 inches (88.9 mm) and a specific gravity of 0.42 or greater. Specified fasteners are required on both sides of panel joint where panels are joined over a support. See Figure 4A.
- ³ Box/Block Spline fastened at top only, at interior panel-to-panel joints. Specified fasteners are required on both sides of panel joint. See Figure 4B.
- ⁴ Boundary spline shall be solid 1-1/2 inches (38.1 mm) wide, minimum, and have a specific gravity of 0.42 or greater. Boundary supports shall have a minimum width of 3-1/2 inches (88.9 mm) and a specific gravity of 0.42 or greater. Specified spline fasteners are required through both facings. See Figure 4C.
- ⁵ Diaphragms shall be designed by a registered design professional in accordance with accepted engineering practice.

DIAPHRAGM LOAD

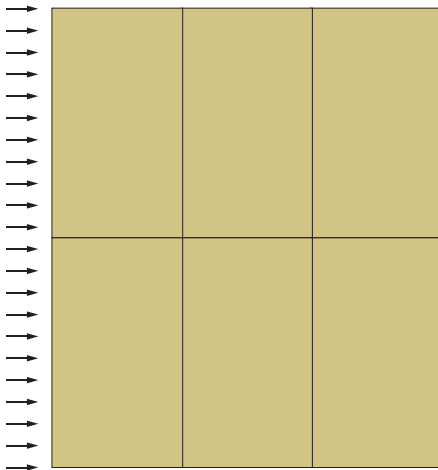

TYPE S SPLINE

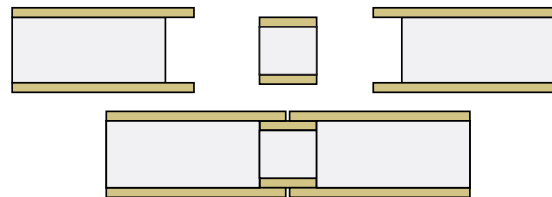

PREMIER WOOD SCREWS

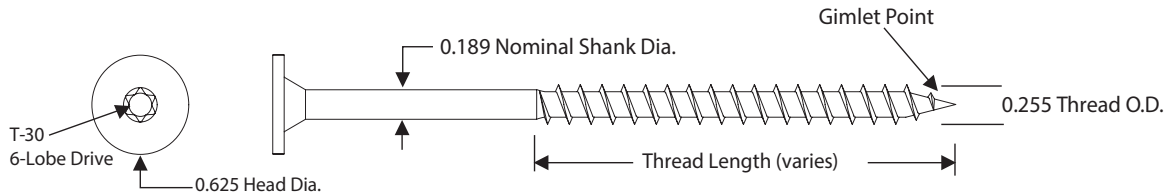

WOOD SCREW PROPERTIES			
Tensile (lbs) AISI S904	Shear (lbs) AISI S904	Bending Yield Strength - Fyb (psi) ASTM F1575	Corrosive Resistance ASTM D6294, ETAG 006
3555	2580	185,000	<15% Red Rust after 30 cycles

WITHDRAWAL: LUMBER & ENGINEERED WOOD - LBS./IN. ^{1,2}							
SPF/HF (0.42)		DF/SP (0.50)		LVL (0.50)		LSL (0.50)	OSB (7/16")
Face Grain	Edge Grain	Face Grain	Edge Grain	Face Grain	Edge Grain	Face Grain	Face
799	615	899	702	556	495	711	265

¹ Load values include fastener tip.

² 1" fastener embedment into face / edge grain.

WITHDRAWAL: CONCRETE & CMU - LBS. ¹		
2500 psi Concrete	5000 psi Concrete	CMU ²
682	869	713

¹ Fastener penetrates 1" into concrete or CMU block, including the tip.

² Concrete Masonary unit (CMU) conforming to ASTM C90.

HEAD PULL-THRU - LBS.	
7/16" OSB	SIP
490	630

LATERAL LOAD RESISTANCE - LBS.		
Main Member	Side Member	Load
SPF ^{1,2}	4-1/2" to 12-1/4" SIP	943

¹ 1-3/4" fastener embedment into edge grain, including tip.

² 1" fastener embedment into face grain, including tip.

NOTE:

Premier Wood Screw properties are provided. All values are average ultimate values. As determined by the project architect/engineer, appropriate safety factors must be used in design.



PREMIER LIGHT DUTY METAL SCREWS

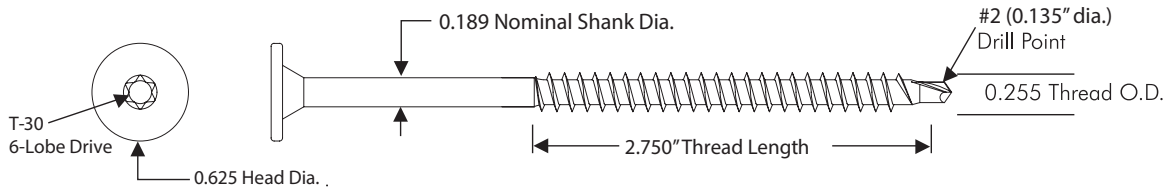

LIGHT DUTY METAL SCREW PROPERTIES			
Tensile (lbs) AISI S904	Shear (lbs) AISI S904	Bending Yield Strength - Fyb (psi) ASTM F1575	Corrosive Resistance ASTM D6294, ETAG 006
3390	2490	185,000	<15% Red Rust after 30 cycles

WITHDRAWAL: CORRUGATED STEEL DECK - LBS.						
24 ga. (36 ksi)	22 ga. (36 ksi)	22 ga. (85 ksi)	20 ga. (36 ksi)	18 ga. (36 ksi)	16 ga. (36 ksi)	16 ga. (100 ksi)
250	381	435	449	694	896	1186

* Minimum 3/4" penetration of fastener through deck from underside of deck.

WITHDRAWAL: LUMBER & ENGINEERED WOOD - LBS./IN. ¹							
SPF/HF (0.42)		DF/SP (0.50)		LVL (0.50)		LSL (0.50)	OSB (7/16")
Face Grain	Edge Grain	Face Grain	Edge Grain	Face Grain	Edge Grain	Face Grain	Face
662	497	732	720	540	469	646	284

¹ Load values include fastener tip.

HEAD PULL-THRU - LBS	
7/16" OSB	SIP
490	630

NOTE:

Premier Light Duty Metal Screw properties are provided. All values are average ultimate values. As determined by the project architect/engineer, appropriate safety factors must be used in design.

PREMIER HEAVY DUTY METAL SCREWS

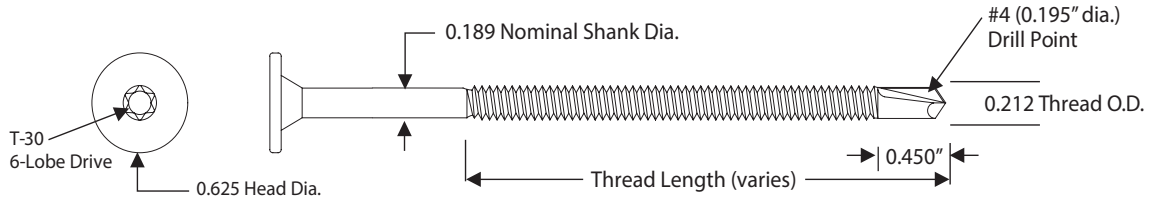

HEAVY DUTY METAL SCREW PROPERTIES			
Tensile (lbs) AISI S904	Shear (lbs) AISI S904	Bending Yield Strength - Fyb (psi) ASTM F1575	Corrosive Resistance ASTM D6294, ETAG 006
3855	2625	185,000	<15% Red Rust after 30 cycles

WITHDRAWAL: CORRUGATED STEEL DECK - LBS. ¹					
16 ga. (36 ksi)	16 ga. (100 ksi)	12 ga. (50 ksi)	1/8" (36 ksi)	3/16" (60 ksi)	1/4" (60 ksi)
491	794	1255	1454	3098	3814

¹ Minimum (3) threads of penetration of fastener through deck as measured from underside of steel.

HEAD PULL-THRU - LBS.	
7/16" OSB	SIP
490	630

LATERAL LOAD RESISTANCE - LBS.		
Main Member	Side Member	Load
1/8" Structural Steel ¹	4-1/2" to 12-1/4" SIP	929

¹ Minimum (3) threads of penetration of fastener through steel as measured from underside of steel.

NOTE:

Premier Heavy Duty Metal Screw properties are provided. All values are average ultimate values. As determined by the project architect/engineer, appropriate safety factors must be used in design.

SCREW WITHDRAWAL CAPACITIES OF OSB

To finish a project that utilizes Premier SIPS for the walls and roof of a structure, many types of materials need to be fastened to SIPs. These materials can include siding, roofing materials, other structural elements, cabinets and a host of others.

In many of these applications screws are the preferred method of fastening. To help quantify the performance of screw withdrawal from OSB, a major manufacturer of OSB generated test data on various screw types and sizes withdrawn from various thicknesses of OSB. Prior to the withdrawal testing, the OSB was exposed to three different environmental conditions – dry, wet, wet/dry. Fifteen repetitions of both direct and lateral withdrawal from the environmentally conditioned OSB were conducted on the screw types and sizes shown in the charts below. The following tables summarize the lowest ultimate average value achieved for each screw type and size when withdrawn from three different thicknesses of environmentally conditioned OSB.

Average Direct Withdrawal (Pullout) - lbs.

Screw Size	7/16" OSB	5/8" OSB	3/4" OSB
#6 Deck Screw	177	272	324
#8 Deck Screw	182	309	359
#10 Deck Screw	198	355	363
#12 Roofing Screw	190	312	360
#14 Roofing Screw	177	340	393

These values are ultimate values. Appropriate safety factors should be applied to obtain design values.

Average Lateral Withdrawal (Shear) - lbs.

Screw Size	7/16" OSB	5/8" OSB	3/4" OSB
#6 Deck Screw	198	273	295
#8 Deck Screw	118	197	224
#10 Deck Screw	143	260	301
#12 Roofing Screw	436	581	561
#14 Roofing Screw	466	630	797

These values are ultimate values. Appropriate safety factors should be applied to obtain design values.

NAIL WITHDRAWAL CAPACITIES OF OSB

With the use of Premier SIPS, the attachment of finishing materials such as roof shingles, siding, drywall, etc., is required. The application of these materials is typically accomplished with conventional nail products. An independent code recognized testing agency conducted withdrawal tests following ASTM D1037 procedures to provide data on the direct withdrawal resistance of nail fasteners when driven into the 7/16" OSB face of SIP. The following is a summary of the average ultimate values achieved for various nail fasteners.

Average Direct Withdrawal (Pullout) – Lbs.

Nail Size & Description	Avg. Ultimate Pullout	Nominal Shank Diameter
4d ring shank-drywall nail	133	0.109"
6d smooth galvanized	59	0.12"
Roofing Nail-smooth galvanized	51	0.11"
8d smooth coated sinker	150	0.134"
8d smooth galvanized spiral shank	112	0.12"
8d galvanized ring shank	77	0.12"
8d smooth galvanized	65	0.134"
8d bright box	107	0.148"
10d galvanized ring shank	164	0.165"
16d smooth galvanized	63	1.35"
16d bright box	90	TBD

These values are ultimate values. Appropriate safety factors should be applied to obtain design values.

This data has been compiled to provide manufacturers, designers and engineers with values for the assessment of fastener requirements.

PREMIER SIPS ACCESSORIES

Premier Building Systems has designed, developed, and tested compatible accessories for your Premier SIPS products to achieve the maximum performance. With decades of use in the field, you can be sure these accessories have proven themselves year after year.

ACCESSORIES CONTENTS

- Premier SIPS Screws.....DR-24
- Premier Screw Length Guide.....DR-24
- Premier SIPS Sealant.....DR-25
- Premier SIPS Tape.....DR-26
- Premier SIPS Building Wrap.....DR-27



PREMIER SIPS SCREWS

Premier SIPS screw fasteners are factory made and supplied with your order. The screws were developed specifically for connecting Premier SIPS to each other, beams, purlins and posts of wood and light gauge metal.

ADVANTAGES

- Corrosion resistant coating
- Excellent pull-out resistance
- State-of-the-art tempering and coating technology
- Sizes from 5" to 18" in increments of 1"

APPLICATIONS

- Fasten siding, roofing, structural elements, cabinets and many other components
- To clarify the performance of screws installed in OSB, refer to the "Screw Withdrawal Load Tables" that follow
- Dimensional 2x's require a minimum 1" penetration
- Wall connections require that screws be used 2' o.c.
- Roof connections require that screws be used 1' o.c.
- Frequency of screw fasteners depends on the imposed loads the that SIPS must resist. Installers must follow the requirements specified on Layout Drawings.

PREMIER SCREW

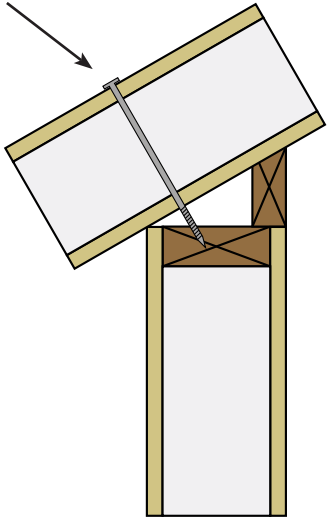

PREMIER SCREW LENGTH GUIDE

SIP THICKNESS ¹					
Slope	4-1/2"	6-1/2"	8-1/4"	10-1/4"	12-1/4"
2/12	6"	8"	10"	12"	14"
4/12	6"	8"	10"	12"	14"
6/12	7"	9"	10"	12"	14"
8/12	7"	9"	11"	13"	15"
10/12	8"	10"	12"	14"	16"
12/12	8"	10"	12"	14"	16"

¹ Minimum 1" thread penetration required.

NOTE:
Premier Screw Length Guide provides recommended Premier SIPS Screw length required based on SIP thickness and roof slope.

PREMIER SIPS SEALANT

Premier SIPS Sealant (as shown on details and in our specification) is supplied by Premier Building Systems with your order. Specifically formulated to help seal SIP connections, Premier SIPS Sealant consists of polymers that are designed to remain flexible and provide a seal against water vapor transmission and infiltration. **All Premier SIPS details call for 3/8" lines of sealant. It is critical that installers follow this direction and apply per manufacturers construction details and instruction.**

ADVANTAGES

- Sealant for all types of SIP construction
- Permanent, non-brittle formula
- Gunable at low temperatures
- Withstands cold and freeze-thaw cycles
- Retains flexibility with age
- Resistant to moisture, dampness, and temperature fluctuation
- Impervious to water wash-out
- Seals EPS and GPS foam, wood products and many other materials

SEALANT QUANTITY ESTIMATING

One 20 ounce tube of sealant applied at a 3/8" bead will yield 27 lineal feet. Periodically check your application to ensure that you are applying sealant at the correct rate.

ADDITIONAL RESOURCES

See Details, Technical Bulletins, and Installation Videos for additional guidance. Current versions are always available online at www.premiersips.com.

RECOMMENDATION

Using electric and pneumatic caulk guns will assist in forming proper bead size and speed up installation.

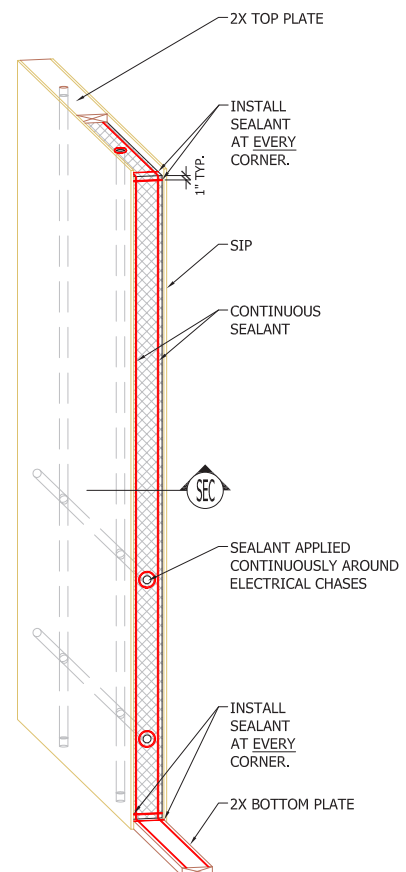
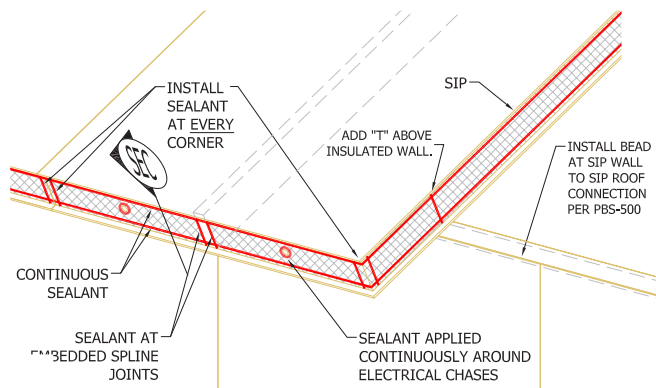

PREMIER SIPS TAPE

Premier SIPS Tape is a patented pressure sensitive, highly durable and superior tape that prevents moist air from penetrating the seams between SIPS and along roof lines. The tape is formulated with a permeance of less than 1, has no VOCs, and offers excellent adhesion to OSB (tested to ASTM D-3330) and most common building materials. The combination of the OSB skins and the Premier SIPS Tape meets the building code requirements for vapor retarders. The Premier SIPS tape shown on our plans and in our specification is supplied by Premier Building Systems with your order. Consult tape details for proper tape width for various wall, roof, and floor joint applications.

ADVANTAGES

- Developed for Premier SIPS panelized construction as a durable, all-weather, air and vapor tight joint sealing tape
- Innovative hybrid synthetic rubber specially formulated to develop a strong bond with OSB and engineered wood products
- High initial tack for immediate bond, offering excellent adhesion to OSB
- Facing is thermally stable, smooth and conformable to irregular surfaces
- High peel and shear strength
- VOC free
- No odors or fumes – meets air quality criteria for use as an interior sealant
- Resists common mold growth
- Does not stain
- Working temperature -40°F to 180°F (-40°C to 82°C)
- Quick & easy installation, no priming required
- For surface preparation and tape installation guidelines refer to Details #Premier-105A and 105B

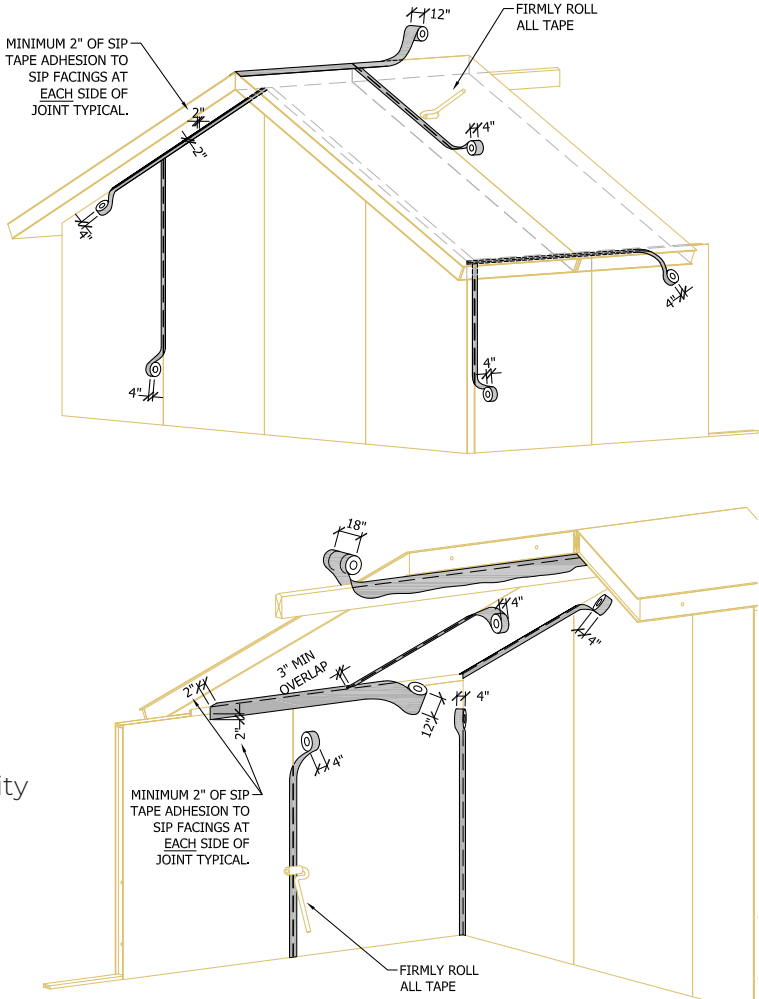

ADDITIONAL RESOURCES

See Details, Technical Bulletins, and Installation Videos for additional guidance. Current versions are always available online at www.premiersips.com.

PREMIER SIPS BUILDING WRAP

OVERVIEW

Premier Building Wrap is a code compliant woven and coated polyethylene fabric with micro-perforations engineered as a Water-Resistive Barrier for use in residential and commercial wall construction (See ICC ESR-2496). Used in conjunction with code approved flashings, helps prevent moisture related issues.

ADVANTAGES

- Twice the tensile strength of most competitive products
- Translucent: easy to cut, fit, fasten
- Protects from harmful ultra-violet rays
- Water Vapor Permeance exceeds 9 perms for breathability
- Large rolls – 10 ft x 150 ft, 27 lbs each



PROPERTIES

PROPERTY	RESULT	TEST METHOD
Tensile Strength	MD 50 (lbs/in) & CD 46	ASTM D882
Air Penetration Resistance	<0.02 L/s/m ² @ 75 Pa <0.004cfm/ft ² @ 1.57 psf	ASTM D779
Water Resistance	Pass	ASTM D779
Water Vapor Transmission	63.1 (grams /sq. meter)	ASTM E96
Water Vapor Permeance	9.1 (perm)	ASTM E96
Canadian Water Ponding	Pass	CCMC 07193
Pliability	Pass	SBCCI
Flame Spread	Class A	ASTM E84
Smoke Developed	Class A	ASTM E84

Contractor Resources

Faster. Stronger. Greener.



Website: premiersips.com

Toll Free: 800-275-7086

Details, illustrations, pictures, and guidelines provided in this Resource Manual give basic information and illustrate examples of Premier SIPS design & installation recommendations. The basic information provided herein is not intended to cover every potential use and application of Premier SIPS. It is the responsibility of the owner and/or the owner's representative to design the insulated wall assembly to perform in a manner ensuring function and durability. Adding an additional insulation component may change the behavior of a wall assembly regarding air movement, water vapor transmittance, bulk water management, and heating, cooling, and ventilation systems. It is the responsibility of the installer to become familiar with each specific application and determine if Premier SIPS are suitable. By commencing work, the installer accepts full responsibility for the proper and safe installation of Premier SIPS at each job site. Furthermore, it is the sole responsibility of the installer to meet all federal and local regulatory requirements for job site safety for every person on the job site while in the execution of all phases of the SIP installation.

CONTRACTOR RESOURCES: CONTENTS

ORDERING & PRODUCTION PROCESS

- The Premier Ordering Process.....CR-2
- Detailed Premier Project LifecycleCR-3
- Guide For Reviewing
Layout Drawings..... CR-8
- Premier SIPS Layout Drawings
Review Checklist.....CR-10

INSTALLATION GUIDELINES

- 5 Steps To Take Prior To SIP
System DeliveryCR-11
- Recommended SIPS Installation Tools...CR-11
- Quick SIPS Jobsite Installation
Best Practices.....CR-12
- SIPS Delivery Preparation CR-13
- Detailed Installation
Recommendations.....CR-14



ORDERING & PRODUCTION PROCESS

THE PREMIER ORDERING PROCESS

You are on your way to building one of the highest performing building envelopes available. When you choose Premier SIPS you are making a positive impact to create more energy efficient, stronger, and healthier commercial and residential structures. The SIP Layout Drawing and Production process depends on a number of factors. The most important thing to remember is that this is a two step process: First we must work with you, our client, and possibly 3rd parties to create the SIP Layout Drawings, and once completed we enter the production schedule.

The text box colors in each stage of the process have been broken into two categories:

Client Responsibility

Premier Building Systems Responsibility

Due to the extreme variability in the time it takes for projects to progress through the drawing process, it isn't possible for us to reserve a production slot until step #6.



DETAILED PREMIER PROJECT LIFECYCLE

On behalf of Premier Building Systems (Premier), we would like to thank you for placing your confidence in our products. You have chosen what many in the building industry believe to be the future of building – SIPS! We feel you are purchasing the best structural insulated panels manufactured in America today.

The process used to create a structure using SIPS is a bit different than traditional construction. Premier SIPS are manufactured with extreme precision in our state-of-the-art manufacturing factories. Just like a window and cabinet package is custom manufactured to each project, successful SIPS installations require pre-planning before factory production and jobsite delivery. This upfront pre-planning can significantly reduce the installation time in the field.

This document is designed to walk you through the steps in this process. As we work together to complete your project, the following pages outline the process and explains what to expect during the project lifecycle. Please refer to these guidelines often as we progress through the milestones of your Premier SIPS project.

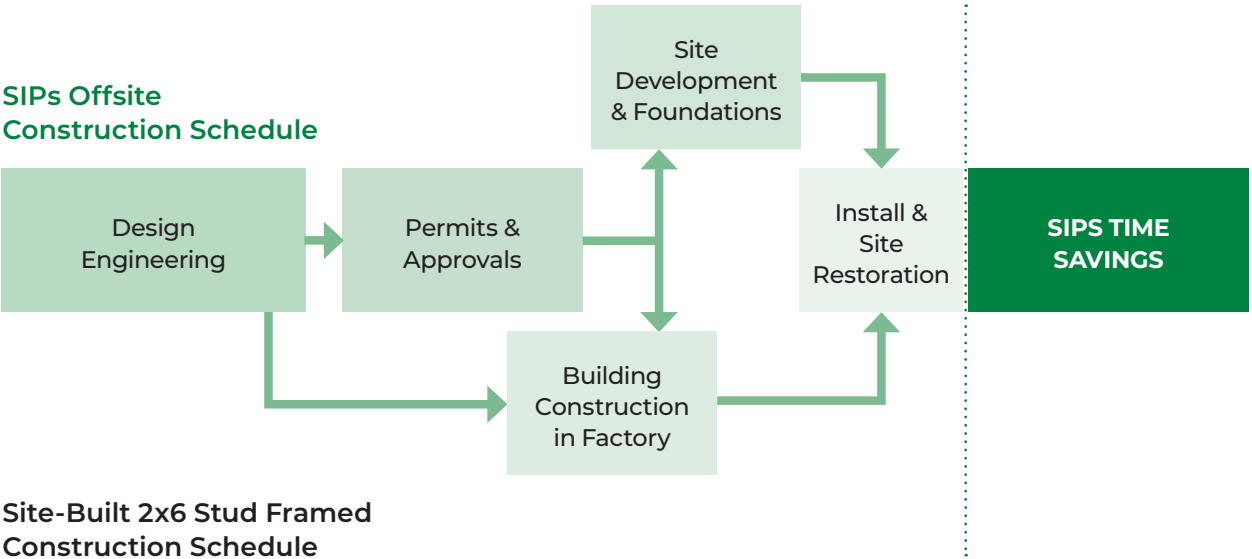

THE PROCESS ... STEP-BY-STEP

1. SUBMITTAL OF PLANS FOR AN ESTIMATE

Architectural or designer building plans are submitted to your local Premier SIPS Representative to establish a Project Estimate (electronic file formats, such as a .PDF are appreciated). In most cases your Premier Representative will provide a project estimate within 5-10 business days. The more detailed your building plans, the more accurate we can be in providing you an accurate estimate. However, Premier is providing an estimate based on the initial information provided. There are often changes made by the customer, architect, engineer or builder, as well as alterations to layout requirements that are very difficult to estimate prior to final SIP drawings being signed and approved.

2. APPROVING THE ESTIMATE

Along with pricing, the “Project Estimate” includes the terms and conditions from which both parties will be operating. It will be necessary to sign and return the document, acknowledging you understand these terms and conditions and that you would like Premier to proceed. For an Estimate to be approved and the project to begin, Premier requires the following:

- Signed estimate with the attached Terms and Conditions by legal/authorized project representative.
- A non-refundable deposit to initiate the drafting and project management process.

3. PREMIER POINT OF CONTACT

You will be assigned a dedicated Premier SIPS Project Manager. Your “PM” will be your primary point of contact throughout the duration of your project. He or she will provide you with interpretive SIP Layout Drawings (Layout Drawings), typically within 10 business days of Premier’s receipt of the completed elements in #2, for your review and approval.

4. CUSTOMER REVIEW OF SIP LAYOUT DRAWINGS

Your review of the Layout Drawings is the most critical component of the entire process. It will set the stage for Premier manufacturing to fabricate the SIPS to your specifications. The Layout Drawings you receive from your PM are interpretations of the building plans you have provided. It is ultimately your responsibility to review these Layout Drawings for accuracy and approve them by signing each drawing in the set. We strongly encourage you to utilize a lead design professional, either an architect or experienced builder, while reviewing your drawings.

5. SIPS ENGINEERING

If Engineering is required, an additional deposit may be required at time of service (Contact your PM). If some engineering cost was included as part of the estimate, when the actual engineering costs are determined, they will be included on the Contract of Sale (COS) with the additional deposit being applied against the total price on the COS.

6. REVISION PROCESS

It is very likely you will have modifications to the Layout Drawings you receive. Once Premier receives your “red-lined” (marked-up) changes, we will make every effort to get the drawings revised and back to you within 5 business days. A marked-up set of Layout Drawings is the preferred method to communicate changes or corrections. Verbal changes or an emailed list may delay revisions or cause an additional set of revisions. It is important to review your entire set of revised drawings, as a revision to one component may affect adjacent SIPs.

There are occasions where this process of revisions may take more than one cycle. Depending on the number of revisions made, the review process will vary in length. As the reviewer, you have a great deal of influence on the overall revision process and its effect on the total project lifecycle. Two rounds of revisions/edits are included in the initial pre-production services portion of the Premier SIPS estimate. Additional revisions may incur additional fees.

7. RECEIPT OF FINAL APPROVED DRAWINGS

Once your Premier SIPS PM receives the final approved and signed SIP Layout Drawings, they are then turned into production-ready drawings, known as “Production Details” from which Premier Manufacturing will fabricate your SIPs. This step also requires “nesting” of the panels for best utilization; safe stacking; and any sequencing requirements you may have. Your PM determines the final material requirements based on these production drawings, develops a final “Contract of Sale” (COS) incorporating the final price (including revisions and any change orders). The COS will be submitted to you within 5 business days for your signed approval.

8. APPROVAL TO PROCEED WITH PRODUCTION

Your approval and return of the signed Contract of Sale (COS), along with a down payment in the amount of 50% of the project’s contract price will initiate the production process. Projects will not go into production without this down payment. Payments can be made via credit card (3% fee applied to credit card transactions), wire transfer or check. However, if paying by check, there is the possibility of delays based on the time it takes for the check to clear. Please keep this in mind as production will not begin until the check has cleared.

At this point, it is extremely important that you are completely ready to proceed. Your project is unique and custom fabricated, which means Premier is unable to resell or restock your products after manufacturing. As a result, by giving approval to manufacture, you will be liable for the project, even if for some unforeseeable reason you must cancel. If you have any questions, please contact your PM prior to submitting the COS.

9. PRODUCTION

After the signed COS & 50% down payment have been received and funds have cleared, the project will be put into the production schedule. Important note: We need to have signed Layout Drawings, signed COS (or PO for applicable customers), and down payment prior proceeding any further. Projects will ship from our manufacturing facility based on our current lead time (Contact your PM). Lead time is determined after receipt of the signed COS and the clearing of funds (item #8). Once your project has entered production, any changes made to the project at this time may result in a delayed shipment (and additional charges), as changes cannot be made to SIPS once fabrication has begun.

10. SCHEDULING DELIVERY OF PREMIER SIPS

Within 10 business days of your project entering production, the Premier Shipping Manager will contact you to confirm/schedule your delivery date (based on the date in your COS). The final balance due must be paid in full (and all funds made via check must clear) before the Shipping Manager can release your completed project for shipment – unless other arrangements have been made.

11. PAYMENT OF OUTSTANDING BALANCE

Payment of the balance for the project is due prior to shipping unless previous arrangements have been made. If paying by check, please allow time for transit and time for check to clear. Delays in payment may result in delays or cancellations of shipment, which in turn may cause additional charges as noted below in item #14.

12. PREPARING FOR RECEIPT OF YOUR PREMIER SIPS

The last two pages of the COS provide a detailed overview concerning the delivery of your Premier SIPS. We strongly encourage you to revisit this document a few days prior to delivery to insure you are in position to receive the product.

Unlike the many pieces used in conventional framing, SIPS take up a large footprint. Planning through this stage for your construction site will make it easier for SIPS installation.

13. RECEIVING YOUR PREMIER SIPS

It will be necessary to have someone on site to receive the shipment. This person must physically inventory the Premier SIPS and other materials delivered based on the packing list provided with the shipment. If anything is missing or damaged, you must make note of it on the "Packing Slip" provided by the Delivery Driver. Then notify your Premier PM immediately in order to assist with remedying the situation. There are occasions, due to the customization of each SIP and particularly with smaller SIPs, that it might appear a SIP is missing, when in actuality, it resides within the shipping load, but nested among other SIPs. Through our load diagrams and pictures taken during load-out of the trucks, our shipping staff should be able to help if something is believed to be missing. Again, it is critical to document damaged or missing pieces on the "Packing Slip" and to notify your Premier PM immediately if there are any possible concerns with the load.

Per the Terms and Conditions included with the estimate document, it is necessary to notify Premier, in writing, within 15 days of delivery, should you find any perceived defects or non-conformance of the product you received. Beyond this period, the product will be considered to have been received without exception. If, for any reason, you do not plan on installing the Premier SIPS within 15 days of delivery, an inspection and notification of any non-conformance, would still be required within this time period for a claim to be considered.

14. DELAYS TO DELIVERY

We recognize delays occur with projects. At the same time, it is very difficult for us to store and maintain projects in a protected environment once they have been produced.

To accommodate slight schedule delays, Premier will store panels up to 1 week beyond the scheduled delivery date at no charge. Beyond this period, there will be a weekly charge of \$300 (per truckload) per week for storage. If the project is delayed beyond one month, Premier will invoice the customer to pay the full balance due upon invoice receipt. Additionally, any delays to delivery within 48 hours of the scheduled shipment will result in an additional \$350 freight rescheduling fee. It is in no way Premier's desire to pursue these fees, but the liability of storing and the inability to restock custom manufactured products affects Premier's ability to operate effectively.

LAYOUT DRAWINGS & CONSTRUCTION DETAILS

As mentioned throughout the process, each custom Premier SIPS package will be delivered with Layout Drawings, which include specific Construction Details for each project. Keep these in a safe place on the jobsite, as Contractors and Installers will refer to these often.

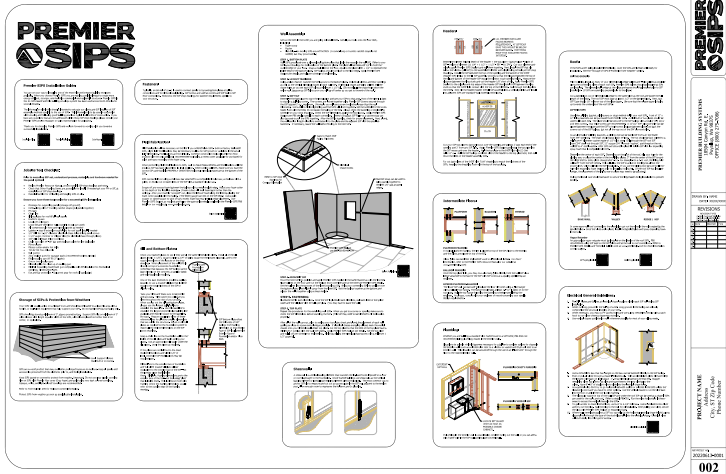

We hope these guidelines help layout the process from approval to proceed with drafting through the receipts of your Premier SIPS order. Typically, you can expect a project to take from 4-12 weeks, but that time frame can vary significantly for a variety of reasons. The customer review, permit process, engineering changes, customer approval and payment steps are elements over which, you as the customer, have control, and when not performed in an expedient manner, can add days, weeks, or even months to the project timeline.

It is our overriding mission to provide you with the product you want, when you want it, to the standards you expect. You have shown, by purchasing Premier SIPS, that you are willing to invest in the very best products available to construct your building envelope. We are honored to have the opportunity to be a part of this investment. Please contact us with any questions before, during, or after construction.

GUIDE FOR REVIEWING LAYOUT DRAWINGS

1. The SIP Layout Drawings for each project are based on the information furnished to Premier Building Systems (Premier). Proper installation of Premier SIPS should be done by a licensed Contractor. It is the Contractor's responsibility to comply with all applicable federal, state, and local codes, regulations, and safety measures.
2. Premier SIP Layout Drawings are for illustration purposes and SIP assembly. As such, these SIP Layout Drawings are not to be considered a replacement for the expertise of an Architect or Engineer, nor their drawings. These SIP Layout Drawings exclude any design of site, foundation, mechanical, electrical, or plumbing. SIP Layout Drawings are to be used in conjunction with Architectural and Structural Drawings. If anything is not clear or there are questions they should be immediately directed to the Architect or Engineer of record.
3. Premier makes every effort to supply complete SIP Layout Drawings from the original Architectural and / or Structural Drawings provided to us. It is the responsibility of the Contractor or Owner to check and verify all dimensions, notes and details on the SIP Layout Drawings for compatibility with the Architecturals and other consultants' drawings and existing conditions prior to commencement of work (check list for this follows). Premier SIPS are fabricated per these SIP Layout Drawings. Any discrepancies or missing items in these Layout Drawings should be noted.
4. Should any discrepancies or omissions be found, the Contractor or Owner must notify your Premier Representative in writing, as soon as possible so that corrections can be made before SIP fabrication begins. A Contractor should look through the plans carefully to ensure that all aspects of the SIP package can be constructed through their preferred means and methods prior to signing off on the SIP Layout Drawings.
5. The Contractor or Owner shall notify premier in writing of any changes to the site and field condition which may affect the SIP layout, prior to the start of SIP fabrication.
6. It is the Contractor's or Owner's responsibility to provide a level and square foundation to ensure a good fit of the Premier SIPS. Premier does not assume responsibility for any variances from the final signed Layout Drawings, including any specifications or adjustments required resulting from the conditions encountered on the job site.
7. The details on the Layout Drawings may not be all inclusive. SIPS must be installed per the Premier SIPS Resource Manual. All available construction details can be found in the Resource Manual or at www.premiersips.com.
8. Some dimensions can not be verified until constructed. Therefore, Premier takes no responsibility for field fabrication. Some field fabricated areas may have been highlighted on the SIP Layout Drawings, but may not be limited to only those areas.
9. It is the Contractor's responsibility to determine all materials necessary for SIP installation. This includes verifying that the materials Premier will be providing (per the Contract of Sale) are adequate for the project and sourcing any additional materials required for SIP installation. All dimensional or engineered lumber, steel, etc. used for any purpose and not noted on the Layout Drawings, shall be supplied by others. Required support beams, columns, dimensional lumber and headers not noted on the Layout Drawings must be designed and supplied by others. Contractors should contact your Premier Representative for clarification on any material needs – ideally prior to SIPS production.

10. SIP wall and/or roof Layout Drawings include locations of factory electrical chases as indicated in the legend below. Additional “custom” electrical chases may be added for a fee. All field cuts, including electrical and plumbing chases, must be in accordance with the Premier SIPS Resource Manual, or pre-approved by Premier.
11. The Contractor or Owner is responsible for verifying all SIP Layout Drawing dimensions to ensure compliance with Architectural and Structural Drawings. All corrections must be “red-lined,” including accurate dimensions, on SIP Layout Drawings in order for Premier to revise the Drawings. If applicable, indicate which end of the dimension will be relocating. Unchecked dimensions may result in the need for field fabrication.
12. Premier accepts no responsibility for Construction, Architecture, or Engineering.
13. Execution of work for installing a SIP package may require coordination with other trades (i.e. Electrician, HVAC,, Plumber, Window/Door Installer, etc.). This coordination is the responsibility of the Contractor.
14. All elevations drawn are viewed from the exterior unless otherwise noted.
15. When built properly a SIP building provides a tight envelope. It is the responsibility of the Contractor to ensure that the SIP structure is properly ventilated to ensure proper air quality and humidity levels.
16. It is the Contractor’s sole responsibility to ensure that all spline connections are properly seated into the SIP recesses and completely sealed with Premier Sealant and SIPS Tape per Premier SIPS Construction Details. Voids between spline connections/joints are not acceptable in a proper SIP installation. Only use expanding spray foam where indicated within Premier SIPS Construction Details, including but not limited to, penetrations, lifting holes, electrical boxes, top of SIP wall/roof connections, etc.
17. The Contractor is responsible to determine the proper weather barrier (i.e. building wraps, flashing, roof underlayment, etc..) to dry in the building envelope.
18. You may experience dimensional variances from the Layout Drawings as SIPS are assembled having gaps at SIP joints and additional miscellaneous construction variables such as fabrication tolerances, lumber post thickness variances, etc. Minor field cutting of the SIPS, to conform with the approved design, may be required to ensure that the total wall or roof assembly is completed per the construction drawings. Premier will add gaps as indicated on SIP Constuction Details between panel joints (typically 1/8” gap).
19. Consult your Premier Sales Representative or Project Manager if field modifications to the SIPS are required due to deviation from the approved SIP Layout Drawings for any reason.

PREMIER SIPS LAYOUT DRAWINGS REVIEW CHECKLIST

Two rounds of revisions/edits are included in the initial pre-production services portion of the Premier SIPS Estimate. Additional revisions may incur additional fees.

When you have finished verifying the SIP Layout Drawings and have made any changes/corrections, copy those changes directly on the Layout Drawings and send back to Premier for revisions prior to production.

This checklist is being provided for the express purpose of assisting our customers in the review of these SIP Layout Drawings against the plan set currently on file and for accuracy and completeness. This helps ensure the quality of the product and ease of construction in the field. Please feel free to contact your premier project manager with any questions or concerns that may arise during the review process.

- Confirm window rough opening locations & dimensions
- Confirm door rough opening locations & dimensions
- Confirm wall plate height dimensions
- Confirm roof pitches
- Confirm roof overhang dimensions
- Confirm beam sizes and locations
- Confirm design value criteria (this page)
- Confirm overall wall dimensions including steps in foundation if applicable
- Confirm floor thickness and dimensions
- Confirm SIP floor panels have solid blocking at point loads
- Denote any custom electrical chase locations with dimensions
- Sign the signature block in lower right corner of this sheet

Any and all discrepancies related to SIPs on site are the responsibility of Owner unless there is a difference between fabricated SIPs and signed SIP Layout Drawings. Premier holds first right of decision to replace, repair or pay for repair of all products in discrepancy with final SIP Layout Drawings.

INSTALLATION GUIDELINES

SIPS DELIVERY PREPARATION

We do our best to ship SIPs sequenced per client request. However, we must also make best use of the available space on each shipment, and ensure that the load is safe for transportation. Bear in mind that all SIPs have markings which make for an easy identification process. If you desire a special loading plan, that request, and layout, must be made concurrent with the return of the signed SIP Layout Drawings and may be subject to an additional fee due to impact on yield, and the total number of shipments required. Premier SIPs are fabricated at 4' & 8' widths and up to 24' lengths. 6' Forks are required for 8' wide SIPs (refer to the contract of sale for more information or ask pbs for a delivery information sheet).

As a supplier of materials only, PBS does not assume responsibility for errors in design, engineering, or dimensions. Owner/agent (architect, contractor, and/or installer) shall verify all dimensions and sizes, and by signing these plans, the owner takes full responsibility for their accuracy. I understand that this structure is to be assembled in accordance with the Premier SIPs Resource Manual.

5 STEPS TO TAKE PRIOR TO SIP SYSTEM DELIVERY

1. Understand the process, gather the materials and hardware needed for a successful SIP panel system installation. NOTE: Regional Representatives may be available for job start assistance to provide recommendations on best practices.
2. Review the resources in this manual, as well as each set of project specific SIP Layout Drawings, Construction Details and notes.
3. Check that other required framing items are accessible for install.
4. If needed, ask your Premier Representative at completion of SIP Layout Drawings for clarification on any of the above.
5. Ensure a Material Handler is available for offloading and staging SIPs on site.

RECOMMENDED SIPS INSTALLATION TOOLS

Ensure you have these tools onsite for a successful SIPS installation:

- Dunnage for supporting panels (storage off ground, set on level surface, max 4' on center)
- Come-along with 2" trucking ratchet straps (pull panels together)
- Pry bars
- Chalk line
- Lifting plates for roof & tall wall panels
- Framers square
- Levels (6' or longer)
- Loose 8d and 16d sinker nails (specific to nail gun used)

- Air compressor air hose and electrical cords as needed
- Ladders - step & extension scaffolding for roof panel install if needed
- 1/2" drill for 1-1/2" diameter electrical chase holes & long panel screws
- 1 1/2" auger, forstner or chipper bits (for electrical chase through plates)
- 3/8" drill or impact driver (cordless)
- Chain saw with 14"-16" bar and chainsaw guide for site fabrication
- Power planer
- Recess cutter and/or hot knife
- T25 & T30 Torx driver bit
- Nail gun(s)
- 20oz sealant guns for sausage packs (recommend cordless electric)
- Reciprocating saw (6" & 12" blades)
- One or two circular saws
- Mineral spirits for clean up of caulking gun
- Minimal expanding foam/foam gun compatible with EPS insulation for mechanical openings, window/door jams
- Eye and Ear protection - Fall arrest gear for roofs (if applicable)
- Forklift Notes: 6' Forks are required for 8' wide SIPs

QUICK SIPS JOBSITE INSTALLATION BEST PRACTICES

1. Handle SIPs with appropriate care. Protect SIP corners and avoid lifting SIPs by edge of top facing.
2. Store SIPs and accessories a minimum of 3 inches above ground/surface. Support SIPs flat on minimum of 3" wide stickers with length equal to the width of the SIPs with stickers placed no further than four feet on center, or equivalent.
3. Protect SIPs and accessories from weather with breathable opaque, white, or light-colored coverings. **IMPORTANT!** Do not use clear or colored plastic films to cover SIPs. Keep SIPs covered to avoid exposure to weather for an extended period of time. Exposure to moisture can cause wood products to swell making installation more difficult. Protect SIPs from weather as soon as practical after installation.
4. Install fasteners flush to SIP facing surface. Be sure not to overdrive screw heads into SIP facings.
5. If field cutting openings be sure that the edge of the opening cuts stop at a common corner. Continuation of the cut past the corner significantly decreases the structural capacity of the SIP.
6. Provide level and square foundations and/or supporting floors. Remove debris from sill plate before SIP installation.
7. Install SIPs in accordance with approved drawings. Double check SIP sizes and electrical chase orientation with SIP Layout Drawings before installation.
8. Details specifying SIP tape and sealant application must be followed.
9. Provide adequate bracing of SIPs during installation.
10. Follow proper nailing requirements according to details and job specific engineering. Be sure to adjust your nail gun so that nail head is flush to SIP facings.

11. Use factory provided electrical chases in SIP rigid insulation core or surface mount conduit. SIP facing should not be cut in the field without consultation with Premier Representative.
12. Make sure to pre-drill top and bottom plates for the vertical electrical chases in the wall SIPs. Pre-drill vertical members at horizontal chase locations.
13. SIPs can be heavy. Lift and place SIPs with appropriate equipment.
14. When using 2x, engineered wood, or I-joist splines, use only continuous members; structural splines must be continuous between supports.
15. Provide appropriate bearing for roof SIPs per details.
16. For climates where SIPS tape is applied on interior joints, this should be done after roofing material has been applied.
17. Before covering roof system make certain that OSB moisture content of top+ bottom facings, and spline material doesn't exceed a maximum moisture content recommendations.
18. Make sure SIPs are clean and dry before applying interior or exterior materials.
18. All SIP roof penetrations should be reviewed by a licensed structural engineer.
20. Use code recognized flashings and exterior wall and roof coverings.
21. Use code recognized thermal barriers on interior per building codes.
22. Plumbing should not be installed within SIPs; see PBS-112 and PBS-111 for alternatives.
23. Fill all voids with expanding foam compatible with eps.
24. SIP structures should be reviewed by a licensed structural engineer. SIP supplier is not responsible for errors in design or engineering.
25. Engineered details take precedence over generic details.
26. Project must meet local code.
27. Field modifications to SIPs, such as openings and penetrations, should be reviewed by a licensed structural engineer.
28. Do not, under any circumstances, cut into the facing of a SIP without speaking to your Premier Representative. If this happens, alert a structural engineer to determine if any areas are structurally compromised.

DETAILED INSTALLATION RECOMMENDATIONS

STORAGE OF SIPS & PROTECTION FROM WEATHER

Your Premier SIPS will usually arrive on a flatbed truck and should be off-loaded to a clean flat area with a forklift, or equivalent equipment that fully support your SIPS. Do not handle SIPS by top facing only.

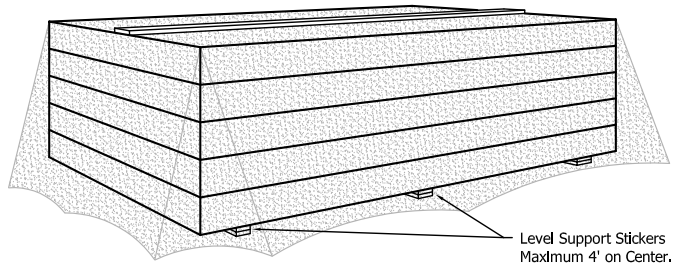

SIPs should be stored a minimum of 3" above ground/surface. Support SIPs flat on minimum of 3" wide stickers with length equal to width of the SIPS, with stickers placed no further than 4' on center, or equivalent.

SIPs are a wood product that may swell after prolonged exposure to moisture. Keep all panels and accessories protected from the elements prior to, and during installation.

Keep SIPS tarped or covered to protect from weather. Important! Do not use clear plastic covering film on SIPS with Premier Max cores (Gray foam) and avoid using very dark colored coverings. Opaque, white, and light-colored coverings are recommended.

Refer to Tech Bulletin I-3 for moisture content information.

Protect SIPS from weather as soon as possible after installation.

FASTENERS

Typically, an 8d nail 6" (o.c.) is used to connect panels to top and bottom plates at spline connections and for dimensional plating. SIP Screws are used at corners and SIP Wall to SIP Roof connections. Reference the SIP Layout Drawings for fastener requirements specific to your structure.

FIELD FABRICATION

Field fabrication will be necessary on the site if you ordered blank SIPS. Even on factory fabricated SIPS, slight field modifications may be necessary to allow for SIP growth or variations in the actual field dimensions. Modifications are not difficult. Common construction tools will suffice for most projects with the only additional recommended tool being a recess cutter (available for purchase) for quick and easy recessing of the foam core.

When performing field modifications to SIPS, wait to make measurements and modifications until the previous SIP has been placed into its final position. When cutting wall SIPS, make sure you have the correct SIP, and that it is PROPERLY ORIENTED (horizontal electrical chases are at the bottom of the SIP).

SIPs can be field cut using a chainsaw bar attached to a compatible circular saw, a chainsaw with a guide, or double cut on both sides of the SIP with a standard circular saw. Because SIPS are a structural assembly consult with our Premier Representative before initiating cuts to facings.

Scrape off any excess foam between the facings with a metal straight edge. Adjust your foam cutter to the depth of the installed member. (Foam cutters will melt foam back further than the setting.) After your foam is "scooped" out, clean the leftover foam along the sides by

placing the foam cutter parallel with the facing. (The depth gauge can rest on the SIP edge.) Use a paint scraper or speed square to take off any excess foam that may inhibit lumber placement. Use Premier SIPS Sealant as required and follow the appropriate details outlined in the Premier SIPS details or our website at: www.premiersips.com.

SILL AND BOTTOM PLATES

Check your bottom plates to see if they are all the same dimension in width. Install all of the sill plates level ($\pm 1/8"$), square (within a $1/4"$ of being square on the longest diagonal), and to the exact dimensions of the layouts on the Layout Drawings. When placement of the wall SIPs is directly on top of a concrete foundation, remember that because the SIP facings cannot bear directly on the concrete, a capillary break and solid bearing is required for both SIP facings.

One of the best methods to provide a capillary break is to use a treated sill plate that is either equal to the total thickness of the SIP or slightly wider.

Take your time and make sure to be precise and accurate. Time spent now will save you time throughout the rest of your project. When you lay out the sill and bottom plates, always use the longest building line to establish the base line. Use this base line to establish the largest perpendicular building line available and make it square to the base line. Be exact. Measure parallel to either of these reference lines for all other smaller dimensions that are within the structure. Adjust or shift sill plates as required on the foundation system to match all the desired dimensions on the SIP layout drawings.

Snap a chalk line on the foundation wall for the inside of the sill plate and begin setting your plates. Use an appropriate sill sealer (Premier SIP Sealant) under the sill plates.

If the plates are not laid out to the exact desired dimensions and within $1/8"$ of level, extensive SIP modifications may be required later.

Dimensions to the exterior face of foundation and full width treated sill plate will be equivalent to the exterior face of the SIP—not the lumber plate that is inside them. Similarly, framing dimensions are to the exterior face of the SIP—not the lumber plate that is inside them. This is different from stick framing where the framing dimensions usually refer to the outside edge of the framing member.

Reference detail PBS-305 (located in the Premier Resource Manual or at www.premiersips.com) for additional information.

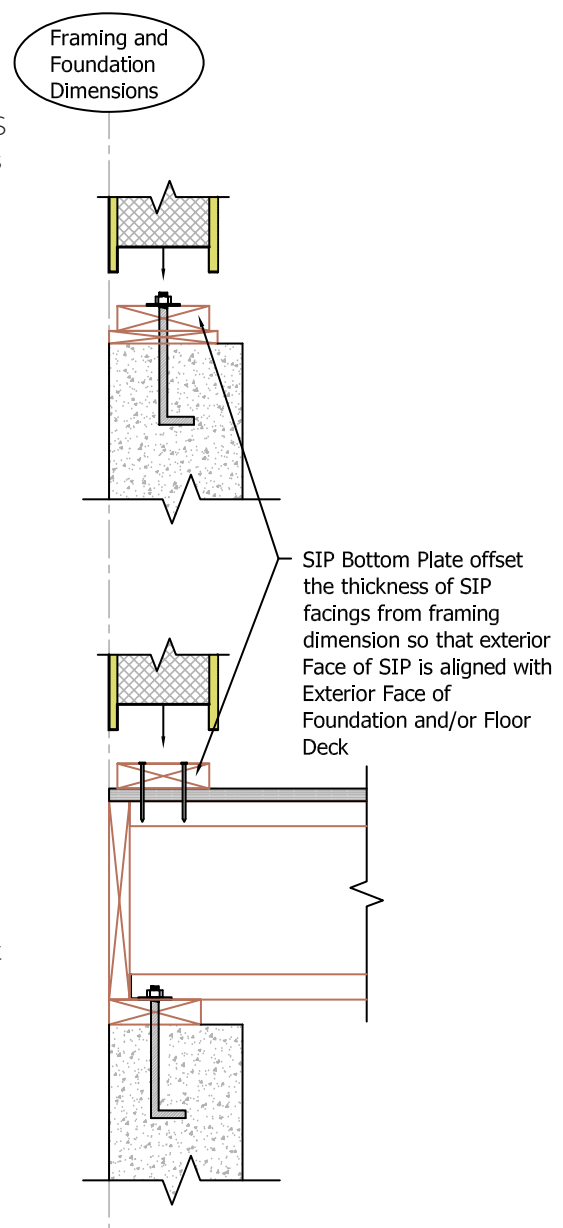

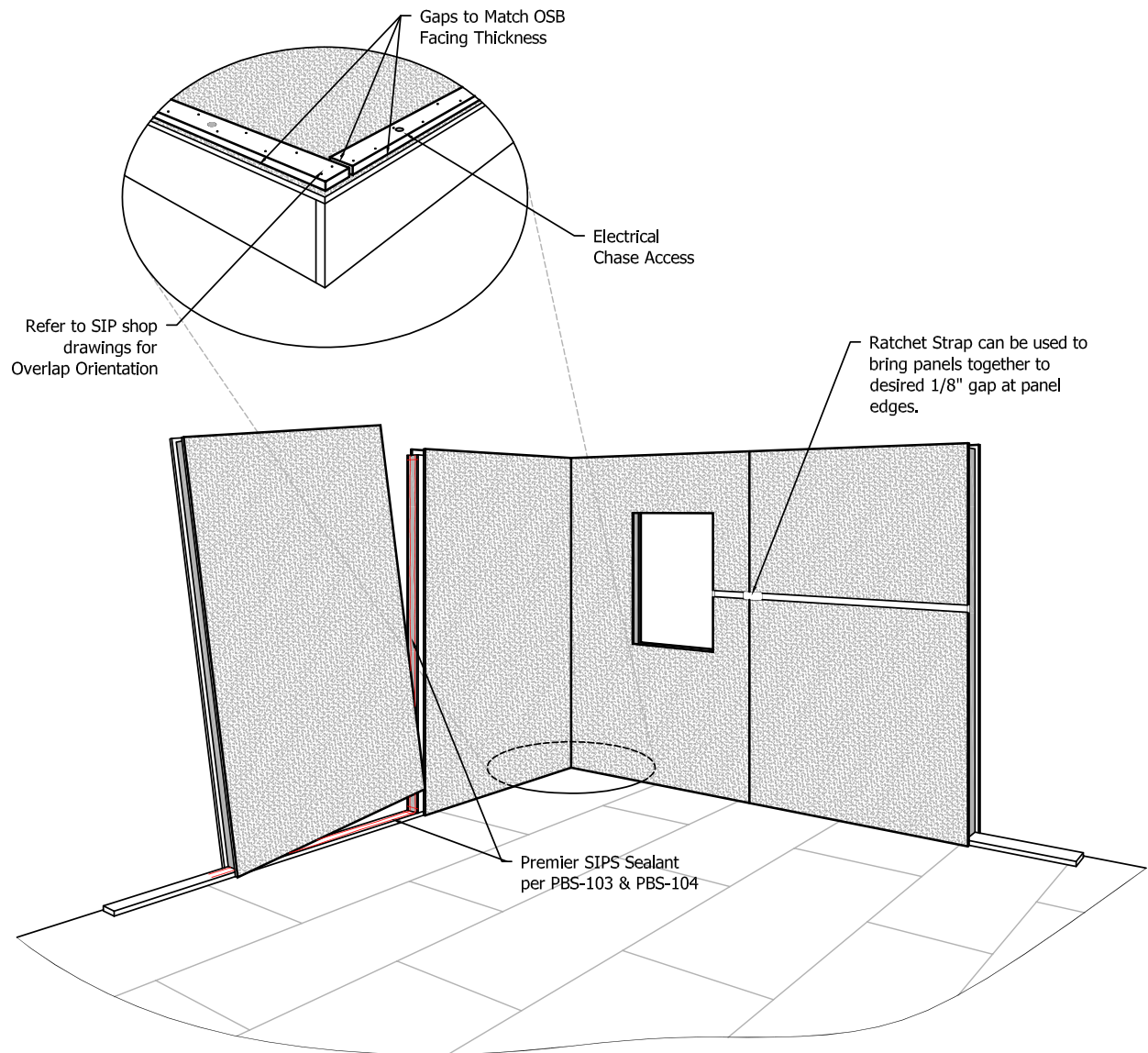

WALL ASSEMBLY

Set out the SIPs in the order you are going to install them. Get all your tools onto the floor deck, including:

- Foam scoop
- Marker
- Flat dolly—for moving SIPs around the deck
- Come-along

STEP 1. BOTTOM PLATE

Wall SIPs are placed over a dimensional bottom plate that fits in the recess in the wall SIP. Refer to your SIP layout drawings for the location of the bottom plate. The plate will be measured $\frac{1}{2}$ " from the outside edge of your floor. Snap a chalk line on the floor, equal to the plate width + $\frac{1}{2}$ "

to represent the inside edge of the bottom plate. SIP facings should run flush to the floor edge. Apply Premier SIPS Sealant per details and nail per schedule or engineering.

STEP 2. LAYOUT TRANSFER

Using a black marker, transfer the SIP layouts to the bottom plate. Include all window and door openings as well as the vertical electrical chases in each wall SIP. If electrical chases are being utilized, drill the chase holes as you set each SIP using a minimum 1 1/2" bit. (Do not drill all the chase holes down the entire wall, because as SIP joints grow you will be off center as you get to the end of the wall.)

STEP 3. SIP TILT

Determine the best place to start the installation and get your SIPs to that area. Most of the time it is best to start in a building corner. The corners are locked together using Premier SIPS Screws secured through the SIP spaced 2' o.c. maximum. (Normally you will use a screw two inches longer than the wall thickness.) Use a drill to finish tightening and the SIPs will cinch together. Set the underside of the screw heads flush with the OSB, do not break the OSB facing of the SIP. Always check the fastening or engineering schedule on your Layout Drawings. Check the SIP dimensions against the floor layout. Apply Premier SIPS Sealant per Premier details specific to each connection. A come-along or ratchet strap can also be used to pull the SIPs together. After the SIP is standing, check for proper placement. Next, plumb the wall section in both directions and fasten it to the plate and the adjacent SIP with the specified fasteners. If necessary, brace the wall before moving to the next SIP.

STEP 4. ADJACENT SIP

Move the next SIP into position and apply Premier SIPS Sealant in the same manner as with the first SIP. Place splines on the floor and run the sealant down one side and up the other per Premier SIPS details. Set the splines into the grooves of the fixed (standing) SIP. Bring your connecting SIP into position over the bottom plate, tilted slightly away from the fixed SIP. Butt the facings together at the bottom and scissor the walls together using a sharp motion.

Reference detail PBS-103 (located in the Premier Resource Manual or at www.premiersips.com) for additional information.

STEP 5. FASTENING

Plumb the SIP in both directions. Once the SIP is plumb in both directions, nail both sides of the spline seam and the sill plate with 8d nails per plan. (You may have to brace the wall.)

STEP 6. TOP PLATE

Repeat the procedures for the remaining wall SIPs. When you get to a corner or opening make sure to check the SIP dimensions before standing the SIP. (This SIP may need to be trimmed to fit the location properly.)

After all of the walls are up, prior to setting your top plate, check and plumb the alignment of each wall, getting as close to square and plumb as possible. If electrical chases are being utilized, mark the vertical chases onto your dimensional lumber top plate. Cut the top plate so that the ends of the top plate have a minimum 2' overlap with the wall SIP seams. Apply Premier SIPS Sealant per provided construction details. Set the top plate and nail it off per schedule or engineering. Finish by drilling the electrical chase access with a minimum 1 1/2" auger bit.



VIEW VIDEO:
Premier
SIPS Sealant
Application

SHEARWALLS

A shearwall is a vertical bracing element that transfers the in-plane forces imposed on a floor or roof diaphragm to the foundation. Wood framed buildings use shearwalls as the vertical bracing element or lateral load resisting element almost exclusively. The most common way to anchor SIPs is to measure and cut out an access plate in the SIP wall adjacent to the tension post. Allow enough room to maneuver the holdown and 2x blocking.

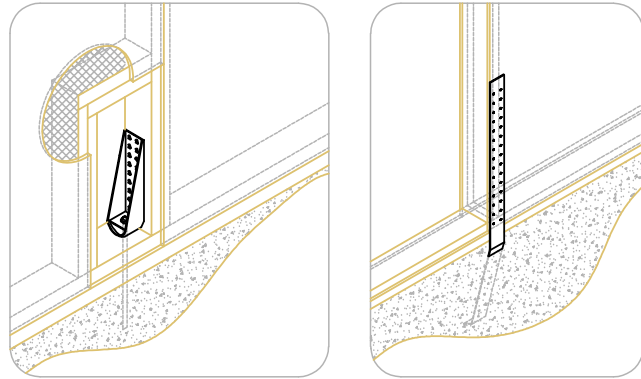

HEADERS

LVL MEMBER INSTALLED FACING BEARING REQUIREMENT. AT SIP ROOF EAVE THIS WOULD BE BELOW BEVELED BLOCK. FOR TRUSS ROOF THIS WOULD BE FACING INTERIOR.

Reference detail PBS-411 (located in the Premier Resource Manual or at www.premiersips.com) for additional information.

IHDR-2 PLY

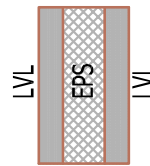

IHDR-1 PLY

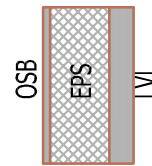

Determine trimmer height: depth of the header + the top plate + bottom plate - height of SIP = height of trimmer ($11\frac{1}{4}'' + 1\frac{1}{2}'' + 1\frac{1}{2}'' - 96'' = 81\frac{3}{4}''$). Cut your trimmer and cripple, apply Premier SIPS Sealant and nail them together. Next, install the SIP that sits below the window (sill SIP) to the assembled trimmer and cripple using 8d nails per SIP Layout Drawings. Install the SIP between the top of the opening and the bottom of the IHDR (header SIP) similar to the sill SIP assembly process so that the distance between the top of the sill and bottom of the header SIP equal the window rough opening height. Measure the distance between the king studs and cut the header $\frac{1}{8}''$ short of this. Apply Premier SIPS Sealant to the cripples and top edge of the Header SIP then install IHDR between the king studs so that the IHDR is in contact with the top of the trimmers. Nail through the kings into the IHDR. Next tilt the header/header SIP/sill SIP assembly into a vertical position and install into adjacent SIP per standard wall assembly techniques.



VIEW VIDEO:
Premier
SIPS Sealant
Application

Cut your SIP top plate to be continuous over the opening and at least 2' past each end of the opening and 2' from any SIP joint. Apply Premier SIPS Sealant and install the top plate into the SIP recess and over the header. Nail the top plate to the IHDR first with (2) 16d nails 12" o.c. Nail the SIP facings on either side of the header to the top plate next, then nail down the sides of the header assembly SIPs.

Fur out both sides of the IHDR with $\frac{7}{16}''$ sheathing to match the thickness of the SIPs, keeping the sheathing flush with the top of the top plate.

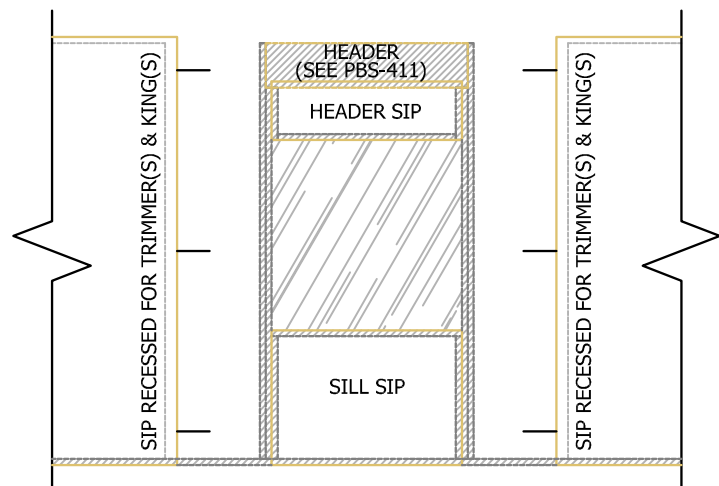

INTERMEDIATE FLOORS

PLATFORM FRAMING

In typical platform framing, the rim is placed on top of the SIP, flush to the exterior, and the joists are placed on top of the SIP.

(Floor joists can be either engineered wood or dimensional lumber. For more information, refer to the Premier SIPS resource manual or our website at www.premiersips.com)

BALLOON FRAMING

Once the top plate is in, you may now also hang joists directly from the wall SIP via a ledger attached to the face of the SIP with SIP screws at a spacing specified by an engineer.

HYBRID PLATFORM-BALLOON

The lower SIP wall can be used to insulate the floor rim when using a joist hanger with a nailable top flange. The flange should bear at least 1.5" (2" is best) on to the top plate. Nail the top flange following the fastening schedule specified by the engineer. As always, consult with your engineer of record concerning your specific design requirements.

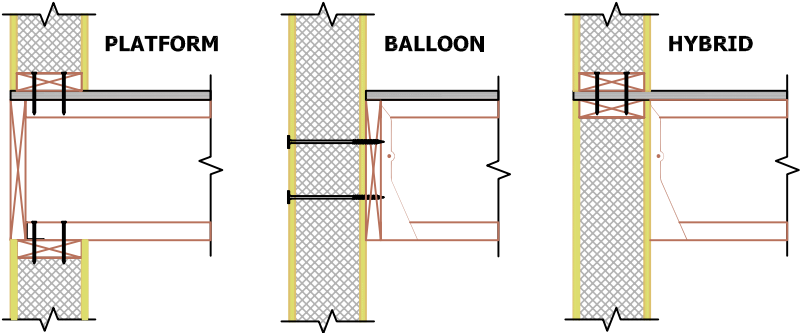

PLUMBING

Whether you are building a standard stick frame house or a SIP home, Premier does not recommend placing plumbing chases in the exterior walls.

Situations do arise in which it becomes necessary for a builder to consider options for chases in the exterior walls such as a kitchen sink next to a window or washer and dryer unit next to an exterior wall. This situation can be answered through the use of an “island vent” through the floor to the nearest interior wall.

If plumbing in the exterior wall is unavoidable, consider furring out the wall, or you can add a stick frame void in the SIP wall and insulate conventionally.

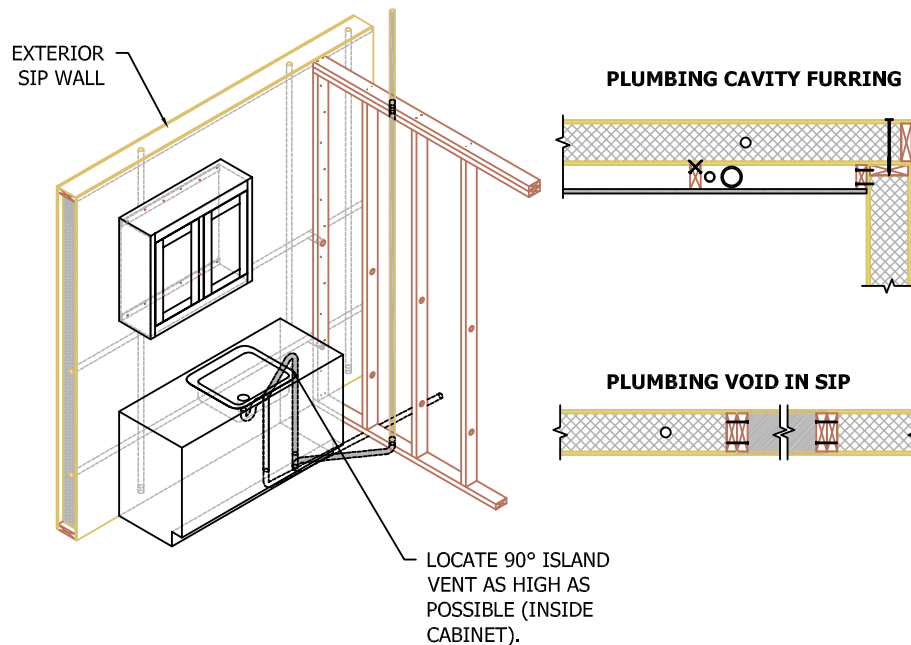

ROOFS

If the SIPs aren't being installed immediately, cover the SIPs and lumber until ready for installation. See the “Storage of SIPs & Protection from Weather” section.

ON THE GROUND

Prior to lifting, install as many of your dimensional lumber splines and I-joint splines as possible along the connecting sides of each roof SIP. Premier SIPs splines should be installed as SIPs are installed. The dimensional lumber at the ridge and eaves should be installed prior to SIP installation. (If SIPs are spanning perpendicular to the ridge.)

Cut a bevel block out of dimensional lumber to the same pitch as the roof and fasten the full length of the ridge. The roof SIP must bear at least 1 1/2” on the beveled block. Next, tack Premier SIP Tape that is 18” wide on top of the ridge beam per provided construction details.. (Be sure that the release paper is facing up towards the underside of the roof SIPs.)



VIEW VIDEO:
Premier
SIPs Tape
Application

LIFTING SIPS

Use either a lifting bracket, picking eye, or strap method to lift your roof. A 12" x 12" lifting bracket can be purchased from Premier SIPS. The plate should be secured to the SIP facings with a total of (35) #10 deck screws. Star drive screws are recommended. A 12"x12" 3/4" plywood shim can be placed between the plate and the SIP to hold screws in place between picks; just back the screws out of the SIP facings, but not all the way out of the 3/4" plywood shim, and it will speed up the process on the next roof SIP to be lifted into place.

As an alternative to lifting brackets, a picking eye can be fashioned from a 4" eye made from 3/4" steel rod. The shaft should be at least 14" long. The nut should be tack welded to a minimum 4" diameter washer made of 1/2" thick steel. Drill through the roof SIP, insert the 3/4" steel rod through the full section of the SIP, apply a 12" square 3/4" Plywood "washer", and thread on the nut welded to the 4" steel washer.

After SIPs are secured in place, remove all the lifting hardware and fill the hole in SIP with low expanding foam that is compatible with EPS. Determine the center of each SIP. Depending on the pitch of the roof, drill your hole for the picking eye, or place the center of the lifting plates, 3" from the center of the SIP toward the ridge end for every pitch change after 4:12. For example: On a 7:12 roof, the lifting hole will be 9" from the SIP center. This will allow the SIP to arrive on the ridge at almost the proper pitch, which will help the SIP installation. If you use the picking eye, be sure to fill the hole with low expanding foam prior to installing roofing felt. (If the roof SIP has installed lumber, the placement of the lifting eye or plate may need to be adjusted.) During the install care should be taken to secure the ridge beam during installation to prevent bowing.

Note: It is the sole responsibility of the contractor and lift operator to select the appropriate methods and means for placing the SIPs of the structure. Further, the contractor and lift operator are responsible for the proper installation of the SIPs following product label instructions and for using all safety precautions during installation to avoid injury to anyone on the project site. The Premier SIPS manufacturer does not accept any responsibility for improper or defective installation workmanship.

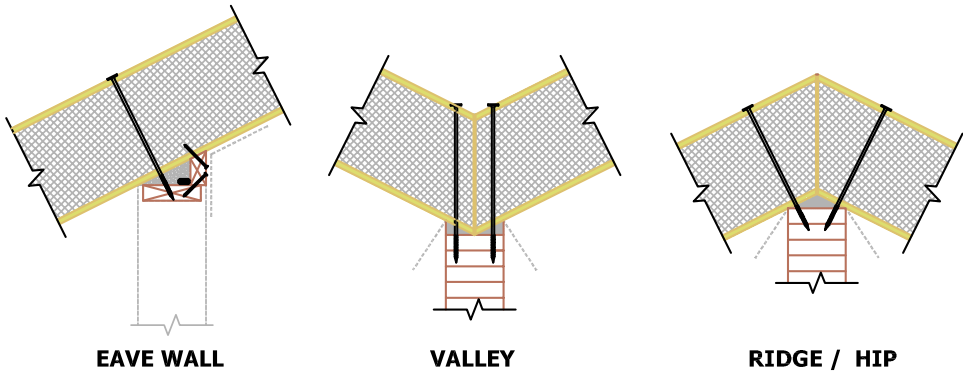

VIEW VIDEO:
Premier
SIPS Tape
Application

In some eave wall/roof connections the electrician can run the wires in the void created by the beveled block. Once the wires are in place, install the beveled block and spray expanding foam in the void.

VAPOR RETARDER

An appropriate vapor retarder must be installed on the interior of the roof SIPs. Premier recommends using Premier SIP Tape on the SIP joints and at the wall to roof connections. Refer to Premier SIPS Details and Technical Bulletins at www.premiersips.com for more information on this subject.

ELECTRICAL GENERAL GUIDELINES

1. Pre-Drill Plates and Splines at electrical chase locations within each SIP wall during SIP installation.
2. Never cut long grooves in the facing of a SIP. Long grooves in the facing can seriously compromise the structural integrity of your SIPs.
3. When necessary, you may cut 4" access holes and use a long remodelers flex bit with a catch hook to run wires where a chase may not exist.
4. Use vertical chases and interior walls whenever possible for most of your wiring needs.

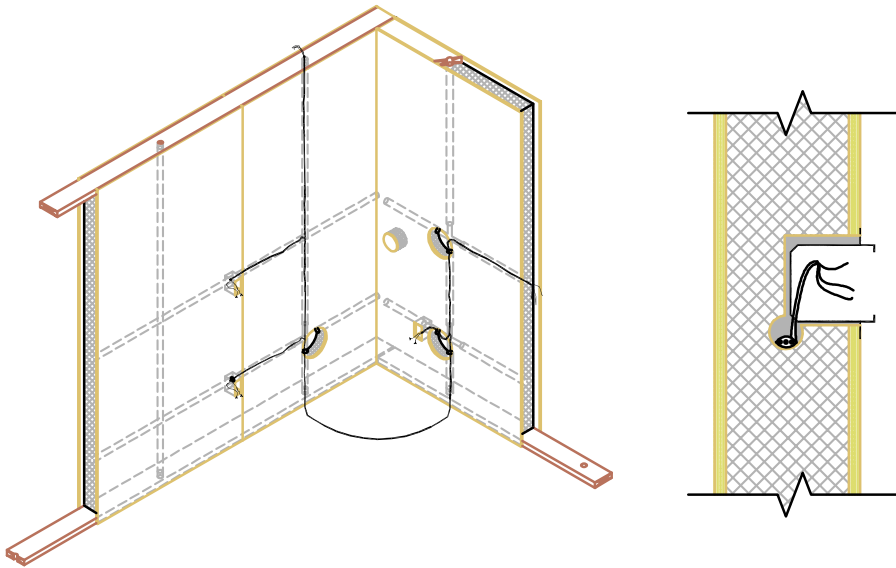

VIEW VIDEO:
Running
Electrical
Wiring in SIPs

5. Use a remodeler's box that has flanges so the box can be fastened directly to the SIP facing.
6. Push or pull all wires through a chase simultaneously. With an electrician's pliers fold and crimp the longest wire back on itself about 1". Wrap electrical tape around that end. Stagger remaining wires flat side to flat side and tape these to the long wire below the crimp. Have 8"-10" of straight wire to slide into the electrical chase holes.
7. As a general rule, don't try to go horizontal between outlets or switches in the SIPs unless the distance is short and you have no other options. Use the vertical chases to run the wire back into the floor or attic if the roof is stick framed.
8. The triangular space on top of the wall SIP and under the roof SIP can be used as a chase if SIPs are used for the walls and roof. Refer to detail PBS-500. Run the wires horizontally in these areas to access the vertical chases in the SIPs.
9. To gain access to chase intersections, use a 4" to 4 1/8" hole saw. Use a flat blade screw driver and pry out the plug. Nail the plug to the wall for reinstallation. After pulling your wires, secure the plug with Premier SIPS Sealant or expanding foam.
10. Where walls terminate against a SIP you can drill (at the horizontal electrical chase height) a long diagonal hole through the face of the stud diagonally into the electrical chase. Electrical wires will stuff easily into this type of access.



VIEW VIDEO:
Premier
SIPS Sealant
Application

Technical Bulletins

Faster. Stronger. Greener.



Website: premiersips.com

Toll Free: 800-275-7086

Details, illustrations, pictures, and guidelines provided in this Resource Manual give basic information and illustrate examples of Premier SIPS design & installation recommendations. The basic information provided herein is not intended to cover every potential use and application of Premier SIPS. It is the responsibility of the owner and/or the owner's representative to design the insulated wall assembly to perform in a manner ensuring function and durability. Adding an additional insulation component may change the behavior of a wall assembly regarding air movement, water vapor transmittance, bulk water management, and heating, cooling, and ventilation systems. It is the responsibility of the installer to become familiar with each specific application and determine if Premier SIPS are suitable. By commencing work, the installer accepts full responsibility for the proper and safe installation of Premier SIPS at each job site. Furthermore, it is the sole responsibility of the installer to meet all federal and local regulatory requirements for job site safety for every person on the job site while in the execution of all phases of the SIP installation.

TECHNICAL BULLETINS

1. BUILDING CODE

BC-1: IECC Insulation U-Factor Requirements.....	TB-2
---	------

2. TESTING

T-1: Premier SIPS Testing Summary.....	TB-7
T-2: OSB Formaldehyde Levels.....	TB-10
T-3: SIP Screw Use in ACQ Treated Lumber.....	TB-21

3. DESIGN

D-1: Premier SIPS Engineering Properties.....	TB-22
D-2: HVAC Design and Energy Calculations.....	TB-24
D-3: Point Loading Walls.....	TB-28
D-4: Premier SIPS Wall Loads (combined axial & transverse loading).....	TB-30
D-5: Shear Wall & Diaphragm Capacity of Premier SIPS.....	TB-34
D-6: Premier SIPS in Floor Applications..	TB-37
D-7: Wind Speed vs. Pressure.....	TB-41
D-8: Sound Transmission of Premier SIPS.....	TB-42
D-9: Splines (minimum width).....	TB-46
D-10: Premier SIPS With Type S (Block) Splines.....	TB-49
D-11: Premier SIPS With Type I (I-Joists) Splines.....	TB-50
D-12: Premier SIPS With Type L (Lumber) Splines.....	TB-52
D-13: Premier SIPS Joint Detailing.....	TB-54
D-14: Premier SIPS Header Options.....	TB-56
D-15: Premier SIPS Screws.....	TB-57
D-16: Screw Withdrawal Capacities of OSB.....	TB-61
D-17: Nail Withdrawal Capacities of OSB.....	TB-62
D-18: Window Installation Details.....	TB-63

4. ELECTRICAL

E-1: Wiring Premier SIPS.....	TB-64
E-2: Recessed Lighting in Premier SIPS..	TB-65

5. FIRE

F-1: Fire Resistive Assemblies.....	TB-66
F-2: Combustion Toxicity of Premier SIPS.....	TB-67

6. INSTALLATION

I-1: Exposure to Excessive Temperature.....	TB-68
I-2: Exposure to Solvents.....	TB-70
I-3: Recommended Exposure to SIPS OSB Skins.....	TB-71

7. MOISTURE

M-1: Sealing Premier SIPS.....	TB-77
M-2: Sealing Requirements for SIPS Used in Commercial Applications.....	TB-78
M-3: Vapor Retarders with Premier SIPS.....	TB-80
M-4: Water-Resistive Barriers Over Premier SIPS.....	TB-82
M-5: Moisture Content of Lumber Used Within Premier SIPS.....	TB-84
M-6: FrameGuard Mold Resistance.....	TB-85

8. ROOF SPECIFIC

R-1: Venting of Premier SIPS Used in Roofs.....	TB-87
R-2: Roof SIPS in Cantilever Conditions.....	TB-88
R-3: Roofing Underlayments Over Premier SIPS.....	TB-91
R-4: Asphalt Shingles Applied to SIP Roof Substrates.....	TB-93
R-5: Low Slope Roofing Over Premier SIPS.....	TB-94
R-6: Metal Roofing Attachment.....	TB-96
R-7: Ventilation of Metal Roofing with Enkamat.....	TB-98

9. WALL SPECIFIC

W-1: Exterior Cladding to Premier SIPS Walls.....	TB-100
W-2: EIFS & Premier SIPS.....	TB-102

SUBJECT: IECC INSULATION U-FACTOR REQUIREMENTS

Premier SIPS are a versatile construction material used as walls, ceilings/roofs, and floors of buildings. Premier SIPS provide both structural capacity and insulation for building envelopes and are available in a wide range of thicknesses to ensure that building owners can meet the most advanced energy code requirements – such as those published by the International Code Council (ICC). This technical bulletin provides a summary of the prescriptive U-factor requirements of the 2021 edition of the International Energy Conservation Code (IECC) published by the ICC. Please refer to the 2021 IECC for further detailed information.

The IECC is a leading energy code that is applicable to both commercial and residential buildings and is often adopted as a code requirement at the state level. State adoption of IECC may also be to the prior versions of the IECC issued in 2015 and 2018.

The tables within this bulletin provide the U-factor requirements of the 2021 IECC Table R402.1.2 (residential) and Table C402.1.4 (commercial) detailed by climate zone (map below) and demonstrates which Premier SIPS thickness meets or exceeds the requirements for each climate zone. The U-factor is the rate of heat transfer per unit area, and per unit temperature difference, and the units are BTU/hr·ft²·F. The lower the U-factor, the greater resistance to heat flow. U-factors equal to or less than that specified in the tables are permitted as an alternative to the R-value requirements of the 2021 IECC Table R402.1.2 or Table C402.1.4.

Alternative paths for conformance through comparison to 2021 IECC “R-value Tables” and detailed analysis are also available within the standard. Premier recommends that the U-factor path be followed since these accounts most appropriately for insulation performance of SIPs in comparison to lumber framing with traditional insulations.

Premier SIPS are available with standard rigid insulation (EPS) core.

Premier SIPS MAX have GPS (Graphite Polystyrene) Insulation core offering higher thermal values.

2021 CLIMATE ZONES

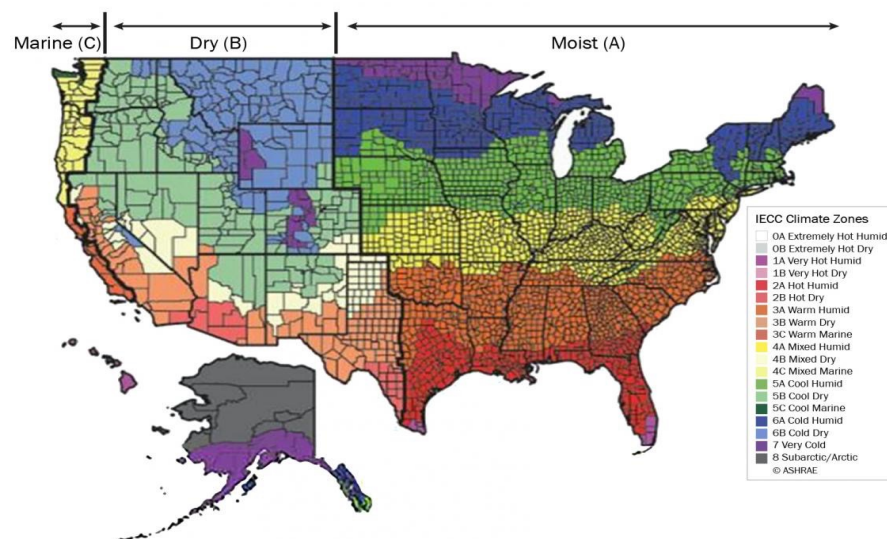

2021 IECC TABLE R402.1.2 EQUIVALENT U-FACTORS ¹							
Residential Walls							
Zone	Wood-Framed Wall Requirement	Premier SIPS					
		4 ½"	Comply?	6 ½"	Comply?	8 ¼"	Comply?
0 - 1	0.084	0.060	Yes	0.041	Yes	0.033	Yes
2	0.084	0.060	Yes	0.041	Yes	0.033	Yes
3	0.060	0.060	Yes	0.041	Yes	0.033	Yes
4	0.045	0.060	No	0.041	Yes	0.033	Yes
4 Marine	0.045	0.060	No	0.041	Yes	0.033	Yes
5	0.045	0.060	No	0.041	Yes	0.033	Yes
6	0.045	0.060	No	0.041	Yes	0.033	Yes
7	0.045	0.060	No	0.041	Yes	0.033	Yes
8	0.045	0.060	No	0.041	Yes	0.033	Yes

¹Premier SIPS U-Factors include inside air film, ½" gypsum wallboard, Premier SIP & outside air film. Values are calculated at 75 degrees.

2021 IECC TABLE R402.1.2 EQUIVALENT U-FACTORS ¹							
Residential Roof/Ceilings							
Zone	Roof/Ceiling Requirement	Premier SIPS					
		8 ¼"	Comply?	10 ¼"	Comply?	12 ¼"	Comply?
1	0.035	0.032	Yes	0.026	Yes	0.022	Yes
2	0.026	0.032	No	0.026	Yes	0.022	Yes
3	0.026	0.032	No	0.026	Yes	0.022	Yes
4	0.024	0.032	No	0.026	No	0.022	Yes
4 Marine	0.024	0.032	No	0.026	No	0.022	Yes
5	0.024	0.032	No	0.026	No	0.022	Yes
6	0.024	0.032	No	0.026	No	0.022	Yes
7	0.024	0.032	No	0.026	No	0.022	Yes
8	0.024	0.032	No	0.026	No	0.022	Yes

¹Premier SIPS U-Factors include inside air film, ½" gypsum wallboard, Premier SIP, asphalt singles & outside air film. Values are calculated at 75 degrees.

2021 IECC TABLE C402.1.4 EQUIVALENT U-FACTORS ¹							
Commercial Walls							
Zone	Wood-Framed Wall Requirement	Premier SIPS					
		4 ½"	Comply?	6 ½"	Comply?	8 ¼"	Comply?
0 - 1	0.064	0.060	Yes	0.041	Yes	0.033	Yes
2	0.064	0.060	Yes	0.041	Yes	0.033	Yes
3	0.064	0.060	Yes	0.041	Yes	0.033	Yes
4	0.064	0.060	Yes	0.041	Yes	0.033	Yes
4 Marine	0.051	0.060	No	0.041	Yes	0.033	Yes
5	0.051	0.060	No	0.041	Yes	0.033	Yes
6	0.051	0.060	No	0.041	Yes	0.033	Yes
7	0.051	0.060	No	0.041	Yes	0.033	Yes
8	0.051	0.060	No	0.041	No	0.033	Yes

¹ Premier SIPS U-Factors include inside air film, ½" gypsum wallboard, Premier SIP & outside air film. Values are calculated at 75 degrees.

2021 IECC TABLE C402.1.4 EQUIVALENT U-FACTORS ¹							
Commercial Roof/Ceilings							
Zone	Roof/Ceiling Requirement	Premier SIPS					
		8 ¼"	Comply?	10 ¼"	Comply?	12 ¼"	Comply?
0 - 1	0.039	0.032	Yes	0.026	Yes	0.022	Yes
2	0.029	0.032	Yes	0.026	Yes	0.022	Yes
3	0.035	0.032	Yes	0.026	Yes	0.022	Yes
4	0.032	0.032	Yes	0.026	Yes	0.022	Yes
4 Marine	0.032	0.032	Yes	0.026	Yes	0.022	Yes
5	0.032	0.032	Yes	0.026	Yes	0.022	Yes
6	0.032	0.032	Yes	0.026	Yes	0.022	Yes
7	0.028	0.032	No	0.026	Yes	0.022	Yes
8	0.028	0.032	No	0.026	Yes	0.022	Yes

¹ Premier SIPS U-Factors include inside air film, ½" gypsum wallboard, Premier SIP, asphalt shingles & outside air film. Values are calculated at 75 degrees.

2021 IECC TABLE R402.1.2 EQUIVALENT U-FACTORS ¹							
Residential Walls							
Zone	Wood-Framed Wall Requirement	Premier SIPS MAX					
		4 ½"	Comply?	6 ½"	Comply?	8 ¼"	Comply?
0 - 1	0.084	0.052	Yes	0.036	Yes	0.027	Yes
2	0.084	0.052	Yes	0.036	Yes	0.027	Yes
3	0.060	0.052	Yes	0.036	Yes	0.027	Yes
4	0.045	0.052	No	0.036	Yes	0.027	Yes
4 Marine	0.045	0.052	No	0.036	Yes	0.027	Yes
5	0.045	0.052	No	0.036	Yes	0.027	Yes
6	0.045	0.052	No	0.036	Yes	0.027	Yes
7	0.045	0.052	No	0.036	Yes	0.027	Yes
8	0.045	0.052	No	0.036	Yes	0.027	Yes

¹Premier SIPS U-Factors include inside air film, ½" gypsum wallboard, Premier SIP MAX & outside air film. Values are calculated at 75 degrees.

2021 IECC TABLE R402.1.2 EQUIVALENT U-FACTORS ¹							
Residential Roof/Ceilings							
Zone	Roof/Ceiling Requirement	Premier SIPS MAX					
		8 ¼"	Comply?	10 ½"	Comply?	12 ¼"	Comply?
1	0.035	0.026	Yes	0.021	Yes	0.018	Yes
2	0.026	0.026	Yes	0.021	Yes	0.018	Yes
3	0.026	0.026	Yes	0.021	Yes	0.018	Yes
4	0.024	0.026	No	0.021	Yes	0.018	Yes
4 Marine	0.024	0.026	No	0.021	Yes	0.018	Yes
5	0.024	0.026	No	0.021	Yes	0.018	Yes
6	0.024	0.026	No	0.021	Yes	0.018	Yes
7	0.024	0.026	No	0.021	Yes	0.018	Yes
8	0.024	0.026	No	0.021	Yes	0.018	Yes

¹Premier SIPS MAX U-Factors include inside air film, ½" gypsum wallboard, Premier SIP MAX, asphalt singles & outside air film. Values are calculated at 75 degrees.

2021 IECC TABLE C402.1.4 EQUIVALENT U-FACTORS ¹							
Commercial Walls							
Zone	Wood-Framed Wall Requirement	Premier SIPS MAX					
		4 ½"	Comply?	6 ½"	Comply?	8 ¼"	Comply?
0 - 1	0.064	0.052	Yes	0.036	Yes	0.027	Yes
2	0.064	0.052	Yes	0.036	Yes	0.027	Yes
3	0.064	0.052	Yes	0.036	Yes	0.027	Yes
4	0.064	0.052	Yes	0.036	Yes	0.027	Yes
4 Marine	0.051	0.052	No	0.036	Yes	0.027	Yes
5	0.051	0.052	No	0.036	Yes	0.027	Yes
6	0.051	0.052	No	0.036	Yes	0.027	Yes
7	0.051	0.052	No	0.036	Yes	0.027	Yes
8	0.051	0.052	No	0.036	No	0.027	Yes

¹ Premier SIPS U-Factors include inside air film, ½" gypsum wallboard, Premier SIP & outside air film. Values are calculated at 75 degrees.

2021 IECC TABLE C402.1.4 EQUIVALENT U-FACTORS ¹							
Commercial Roof/Ceilings							
Zone	Roof/Ceiling Requirement	Premier SIPS MAX					
		8 ¼"	Comply?	10 ¼"	Comply?	12 ¼"	Comply?
0 - 1	0.039	0.026	Yes	0.021	Yes	0.018	Yes
2	0.039	0.026	Yes	0.021	Yes	0.018	Yes
3	0.035	0.026	Yes	0.021	Yes	0.018	Yes
4	0.032	0.026	Yes	0.021	Yes	0.018	Yes
4 Marine	0.032	0.026	Yes	0.021	Yes	0.018	Yes
5	0.032	0.026	Yes	0.021	Yes	0.018	Yes
6	0.032	0.026	Yes	0.021	Yes	0.018	Yes
7	0.028	0.026	Yes	0.021	Yes	0.018	Yes
8	0.028	0.026	Yes	0.021	Yes	0.018	Yes

¹ Premier SIPS MAX U-Factors include inside air film, ½" gypsum wallboard, Premier SIP, asphalt shingles & outside air film. Values are calculated at 75 degrees.

SUBJECT: PREMIER SIPS TESTING SUMMARY

Premier SIPS are Building Code Recognized as complying to national and local building codes that are guided by the International Code Council’s (ICC) series of I Code’s, including the International Residential Code (IRC), International Building Code (IBC) and the International Energy Conservation Code (IECC).

To provide testing and quality control data required by the ICC to achieve I Codes recognition and compliance, Premier SIPS has conduct numerous tests of Structural Capacity, Fire Duration Performance, Energy/Sound values and ratings and the qualification and quality Control of the Components and process of SIP manufacturing.

The summary of Premier SIPS’ testing data and technical information is provided in this Technical Bulletin.

STRUCTURAL						
STANDARD	ASTM E72	ICC-ES AC04	ASTM E455	ASTM E695	ASTM E2322	ASTM E2126
TEST TITLE:	STRENGTH TESTS OF PANELS FOR BUILDING CONSTRUCTION	ICC-ES SANDWICH PANEL ACCEPTANCE CRITERIA	ROOF DIAPHRAGM CONSTRUCTIONS	RESISTANCE TO IMPACT LOADING	CONCENTRATED FLOOR LOAD	CYCLIC (REVERSED) LOAD TEST FOR SHEAR RESISTANCE OF WALLS
ALSO KNOWN AS:	ASTM E1803				IBS SECTION 1607.1	
RESULTS:	<ul style="list-style-type: none"> • Axial Load • Transverse Load • Racking Shear <p>¹ See Premier SIPS Load Charts for structural capabilities.</p>	<p>Premier SIPS meet AC04 requirements</p> <p>⁴ See Premier SIPS ICC-ESR Evaluation Report.</p>	<p>Diaphragm design capacity up to 1,130 plf</p> <p>¹ See Premier SIPS Load Charts for structural capabilities.</p>	<p>Panel supported on short ends withstood repetitive impacts to the center of 90 ft. lbs., 240 ft. lbs., and 600 ft. lbs. with no deleterious effects.</p>	<p>Meets 2,000 lb. concentrated floor load requirement. Floor panels successfully supported 6,000 lbs. placed on 30"x30" area at various locations on the panel and panel joints.</p>	<p>Shear resistance capacity up to 1,000 plf designs for seismic categories A through F.</p>

FIRE					
STANDARD	ASTM E84	UL 1715	ASTM E119	ASTM E119	ASTM E119
TEST TITLE:	SURFACE BURNING CHARACTERISTICS	CORNER ROOM BURN	FIRE TEST OF BUILDING CONSTRUCTION AND MATERIALS	FIRE TEST OF BUILDING CONSTRUCTION AND MATERIALS	FIRE TEST OF BUILDING CONSTRUCTION AND MATERIALS
ALSO KNOWN AS:	UL 723 NFPA 255	FM 4880 NFPA 286	UL 263 NFPA 251	UL 263 NFPA 251	UL 263 NFPA 251
RESULTS:	³ EPS Core Flame Spread: 20 Smoke Developed: 150-300 Interior of panel covered with ½" gypsum board Flame Spread: 10 Smoke Development: 0	PASS Using ½" gypsum board on the interior of the Premier SIP	20 Min. Fire Resistant wall assembly	² 60 Min. Fire Resistant wall assemblies	^{2, 4} 60 Min. Fire Resistant Roof/Ceiling Assembly
			½" gypsum board as interior finish	2 layers 5/8" Type X gypsum board as fire side finish. Passed 30 PSI hose stream Double 2X connection and 1 layer 5/8" Type C gypsum board as fire side finish. Passed 30 PSI hose stream	2 layers 5/8" Type X gypsum board as interior finish

COMPONENTS					
COMPONENT	OSB	ADHESIVE	ADHESIVE	EPS CORE	EPS CORE
TEST TITLE:	WOOD-BASED STRUCTURAL PANELS	ADHESIVES FOR STRUCTURAL LAMINATED WOOD PRODUCTS	SANDWICH PANEL ADHESIVES	SPECIFICATION FOR POLYSTYRENE INSULATION	TERMITE EXPOSURE
STANDARD:	DOC PS2-92 APA PR-N610	ASTM D 2559	ICC-ES AC05	ASTM C578 ICC-ES AC10	ICC-ES AC239
RESULTS:	OSB meets Exposure I - 24/16 span rating qualified as facing of structural insulated panels.	Adhesive meets strength requirements of Class 2 Type II adhesive.	Adhesive used in Premier SIPS manufacture meets ICC-ES Acceptance Criteria for sandwich panel adhesive.	Premier SIPS EPS core (termite treated) exceeds the minimum values in ASTM C578.	^{2, 5} Premier SIPS EPS core with termite treatment recognized by UL to be in compliance with ICC acceptance criteria 239.

^{1, 2, 3, 4, 5, 6} SEE LAST PAGE FOR FOOTNOTES.

ENERGY/SOUND					
STANDARD	ORNL	ASTM C236	ORNL	ASTM E90	ASTM C423
TEST TITLE:	STEADY STATE THERMAL PERFORMANCE OF BUILDING ASSEMBLIES	STEADY STATE THERMAL PERFORMANCE OF BUILDING PANELS BY GUARDED HOT BOX	BLOWER DOOR	SOUND TRANSMISSION CLASS (STC)	SOUND ABSORPTION
ALSO KNOWN AS:	WHOLE WALL R-VALUE	R-VALUE	AIR INFILTRATION		
RESULTS:	4 ½" Premier SIP with ½" gypsum board and plywood siding R = 14.1 2x4 and batt insulation with ½" gypsum board and plywood siding R = 9.6 2x6 and batt insulation with ½" gypsum board and plywood siding R = 13.7	6 ½" Premier SIP with ½" gypsum board mechanically fastened to the interior of the panel R = 21.2 Typical 2x6 construction using fiberglass batts tested under same standard R = 17.2	Controlled room built with 4 ½" Premier SIP = 9 cfm air leakage Typical 2x6 construction using fiberglass batts tested under same configuration = 126 cfm air leakage	6 Achieved STC ratings from STC 28 to STC 59 using various facing assemblies of gypsum, air spaces, fiberglass and isolation cups	6 ½" Premier SIP Noise Reduction Coefficient = 0.15 Sound Absorption average = 0.17

FOOTNOTES:

- ¹ See Premier SIPS Load Charts for complete details.
- ² See ICC-ES report, contact your Premier SIPS supplier for a current copy.
- ³ See UL certificate for complete details.
- ⁴ For specific Fire Resistance, see ICC-ESR 4524.
- ⁵ See rigid insulation literature for complete details.
- ⁶ See Premier Technical Bulletins for assembly details.

ABBREVIATIONS:

ASTM = American Society for Testing and Materials
 IBS = International Building Code
 ICC-ES = International Code Council Evaluation Service
 NFPA = National Fire Protection Agency
 UL = Underwriters Laboratories Inc.
 FM = Factory Mutual

NOTE:

Data for this testing summary derived from the contribution of Premier Building Systems' SIPs Manufacturing Businesses.

QUALITY ASSURANCE

Premier SIPS are made to the standards of an industry leading quality control program monitored by ICC-NTA and recognized by national code agencies.

SUBJECT: OSB FORMALDEHYDE LEVELS

The Oriented Strand Board (OSB) used as the facings for Premier SIPS include very low levels of phenol formaldehyde. Formaldehyde is present in very small amounts of the phenol formaldehyde adhesives used to adhere the structural bond between the OSB wood strands.

Data collected by HUD (HUD CFR 3280.308) indicated that emission levels from moisture resistant phenol formaldehyde adhesives used for structural plywood - OSB were very low; therefore, HUD regulations explicitly excluded plywood / OSB made with phenol formaldehyde adhesives.

The APA, representing the Engineered Wood Association, has researched formaldehyde emissions from APA trademarked products thoroughly and has conducted tests using a large-scale test chamber method for measuring formaldehyde emissions. In this test, OSB is placed within a heated chamber and monitored for formaldehyde emission. Both newly produced OSB and OSB several months after production were tested. The amount of OSB placed within the heated test chamber was significantly greater than the amount of OSB that would be normally used to construct a typical structure.

The testing by the APA, as well as other laboratories, showed that OSB emits less than 0.1 parts per million (ppm) of formaldehyde within the large-scale heated test chamber. This is for both new and aged OSB. Formaldehyde that is emitted by OSB is below HUD standards for allowable emissions.

Attached on the following pages, please find a bulletin authored by the APA and the Engineered Wood Association concerning formaldehyde and engineered wood products.

The APA Bulletin can also be found at www.apawood.org (form J330 “Structural Plywood, OSB exempt from new formaldehyde ruling”).



TECHNICAL NOTE

Formaldehyde and Engineered Wood Products

Number J330E
January 2022

Formaldehyde is a naturally occurring organic airborne chemical that can be synthesized for certain industrial uses, such as adhesives used for wood products, and in the manufacture of many other household goods, such as medical products, carpets and cosmetics. Because elevated levels of formaldehyde may lead to health concerns, regulations exist to limit exposure. These include limits on formaldehyde emissions from some types of wood products. In addition, some green building specifications create a preference for low emitting products. This Technical Note provides facts on formaldehyde and regulations applicable to engineered wood products.

Formaldehyde

At room temperature, formaldehyde is a colorless gas that has a pungent smell at higher concentrations. Small amounts of formaldehyde are naturally produced by humans, animals and plants and may be emitted by fruits, vegetables, trees and raw wood. Formaldehyde is naturally present in outdoor air. Compared to rural air, urban outdoor air concentrations of formaldehyde are typically higher due to human activities, such as traffic and other combustion sources. Indoor air may contain formaldehyde from products that emit formaldehyde, as well as from combustion sources, such as cigarette smoking, cooking or heating fuels. Table 1 shows levels of formaldehyde exposure measured from some typical household activities.

When formaldehyde is emitted into air, it is broken down into carbon dioxide, usually within hours. Formaldehyde is naturally attracted to water, where it is readily absorbed and breaks down. Formaldehyde does not build up in humans or plants. Further information on formaldehyde is cited in the reference section of this publication.

Formaldehyde and Engineered Wood Products

WHAT IS FORMALDEHYDE?

Formaldehyde is a simple chemical made of hydrogen, oxygen and carbon. It occurs naturally and is the product of many natural processes. It is made by human bodies and is in the air. Plants and animals also produce formaldehyde. It is in many fruits and vegetables and is a byproduct of cooking certain vegetables, such as brussels sprouts and cabbage. This chemical breaks down quickly and is metabolized to simple carbon dioxide. Our bodies readily break down the low levels to which people are exposed every day. Formaldehyde is also a product from combustion associated with the burning of kerosene and natural gas, automobile emissions and cigarettes. It is an important industrial chemical used in the manufacture of numerous consumer products, including permanent press fabrics and even toothpaste.

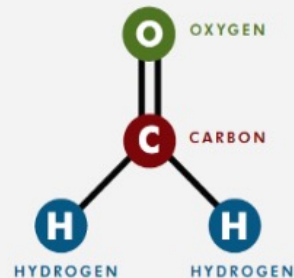

TABLE 1

VARIOUS FORMALDEHYDE EXPOSURE LEVELS

Source/Description	Expected Exposure, parts per billion (ppb)	Footnote (see below)
Painting a 12 ft x 12 ft x 9 ft room	968	(a)
Wallpapering a 12 ft x 12 ft x 9 ft room	2051	(a)
Broil fish using a gas or electric range	105	(b)
Gas range in self-clean mode	337	(b)
Electric range in self-clean mode	183	(b)
One cigarette in small room	49	(c)
Human breath	Around 2	(d)
Typical indoor air	10-30	(e)
Urban air	5-100	—
Rural air	0.8-5	—
Raw wood (emission chamber)	20	—

- Calculated from data taken from the Batelle report for the California Air Resources Board, *Determination of Formaldehyde & Diisocyanate Emission from Residential Indoor Sources*, Contract No. 93-9315, Final Report 1996.
- Indoor Air Quality Residential Cooking Exposures Final Report*, prepared for the California Air Resources Board, CARB Contract Number 97-330, prepared by Ray Fortmann, Peter Kaniher, and Russ Clayton, ARCADIS, Geraghty & Miller, Inc, November 30, 2001.
- Reference taken from the *International Programme on Chemical Safety, Environmental Health Criteria 89* published under the joint sponsorship of The United Nations Environment Programme, The International Labour Organization, The World Health Organization, Geneva, 1989.
- Mass Spectrometric Profile of Exhaled Breath* – field study by PTR-MS, Berthold Moser, Florian Bodrogi, Guenther Eibl, Matthias Lechner, Josef Rieder, Philipp Lirk, 2004.
- Interim Findings on Formaldehyde Levels in FEMA-Supplied Travel Trailers, Park Models and Mobile Homes* from the Centers for Disease Control and Prevention, February 29, 2008.

Formaldehyde Standards and Regulations of Wood Products

Because some adhesives used to produce composite wood products contain formaldehyde, limits on emissions from pressed wood products have been developed in product standards and state and national regulations. In the U.S., formaldehyde regulations of composite wood products began in the early 1980s for particleboard and decorative plywood panels used in manufactured homes (HUD CFR 3280.308). Data indicated that emission levels from moisture-resistant phenol formaldehyde adhesives used for structural plywood were very low; therefore the HUD regulations explicitly excluded plywood made with phenol formaldehyde adhesives.

This Technical Note provides information on formaldehyde regulations that apply to U.S. and Canadian structural engineered wood products. For purposes of this Technical Note, “engineered wood products” are defined as wood products recognized in the U.S. and Canadian building codes for structural applications. Because the vast majority of North American construction involves site-built conditions where exposure to weather is expected, the standards for engineered wood products require moisture-resistant adhesive systems. The inherent structural and moisture durability of these adhesive systems naturally results in very low formaldehyde emissions.

Formaldehyde and Engineered Wood Products

Table 2 provides definitions of the standards, adhesive systems and applications for engineered wood products.

TABLE 2
DESCRIPTION OF U.S. AND CANADIAN ENGINEERED WOOD PRODUCTS

Product	Applicable Standard(s) ^a	Adhesives	Uses
Structural Plywood	U.S. Voluntary Product Standard PS 1 Structural Plywood, U.S. Voluntary Product Standard PS 2 Performance Standard for Wood Structural Panels, CSA O121 Canadian Douglas-fir Plywood and CSA O151 Canadian Softwood Plywood	Phenol formaldehyde	Sheathing for walls, floors, roofs and other industrial and construction uses
Oriented Strand Board (OSB)	U.S. Voluntary Product Standard PS 2 Performance Standard for Wood Structural Panels and CSA O325, Construction Sheathing	Phenol formaldehyde, pMDI ^b	Sheathing for walls, floors, roofs and industrial uses
Structural Glued Laminated Timber (Glulam)	ANSI A190.1 Structural Glued Laminated Timber, CSA O122 Structural Glued-Laminated Timber and CSA O177 Qualification Code for Manufacturers of Structural Glued Laminated Timber	Phenol resorcinol formaldehyde (PRF), melamine, polymer isocyanate, polyurethane ^c	Beams, headers, columns, trusses
Prefabricated Wood I-joists	ASTM D5055 Standard Specification for Establishing and Monitoring Structural Capacities of Prefabricated Wood I-Joists	Phenol formaldehyde, melamine, polymer isocyanate ^d	Floor joists, roof rafters
Structural Composite Lumber (SCL) ^e	ASTM D5456 Standard Specification for Evaluation of Structural Composite Lumber Products	Phenol formaldehyde, pMDI ^f	Beams, headers, studs, flanges of I-joists
Specialty Products – Cross Laminated Timber (CLT), ^g Rim Board ^g , Engineered Wood Siding	ANSI/APA PRG 320 Standard for Performance-Rated Cross-Laminated Timber, ANSI/APA PRR 410 Standard for Performance Rated Engineered Wood Rim Boards, ANSI/APA PRP 210 Standard for Performance Rated Engineered Wood Siding and ICC ES AC 321	Phenol formaldehyde, pMDI, melamine, polymer isocyanate, polyurethane ^g	Specialty construction uses

a. Complete citation of standards is provided in the reference section at the end of this publication.
 b. pMDI = Polymeric Methylene Diphenyl Diisocyanate.
 c. Adhesives must also meet ANSI 405 and ASTM D2559.
 d. Adhesives used to adhere components must meet ASTM D2559 and D7247 in the U.S., and CSA O112.7, O112.9 or O112.10 in Canada.
 e. SCL includes laminated strand lumber (LSL), laminated veneer lumber (LVL), parallel strand lumber (PSL) and oriented strand lumber (OSL).
 f. Adhesives must meet ASTM D2559, D5456 and D7247 in the U.S. and CSA O112.6, O112.9 or O112.10 in Canada.
 g. Adhesives must meet ANSI/APA PRG 320.

Formaldehyde and Engineered Wood Products

Table 3 provides formaldehyde emission results from a limited APA test program, where engineered wood products were tested using the ASTM E1333 large chamber test method.

TABLE 3

TEST RESULTS OF FORMALDEHYDE EMISSIONS FROM ENGINEERED WOOD PRODUCTS.^a

Product	Test Chamber Loading Ratio (ft ² /ft ³) ^b	Range of Test Results (ppm)
Structural Plywood	0.130	0.01-0.04
OSB	0.130	0.02-0.03
LVL	0.016	0.00-0.01
I-joists	0.210	0.01-0.08

a. APA Report T2018L-18, Benchmarking Formaldehyde Emissions From Structural Plywood, OSB, LVL and I-joists.

b. Test chamber loading ratio in ASTM E1333 is defined as the surface divided by the chamber volume. The test method specifies loading ratios for some wood products, but does not specify loading ratios for structural engineered wood products. Loading ratios for structural engineered wood products were based on technical analysis of the surface area to air volume ratio of the products used in construction applications.

U.S. and Canadian Formaldehyde Regulations Applicable to Engineered Wood Products

1. U.S. HUD Manufactured Home Construction and Safety Standard (CFR 3280.308)

This standard specifies a 0.20 ppm emission limit for plywood and a 0.30 ppm limit for particleboard when tested with the ASTM E1333 Large Chamber Method. The intent was to regulate the specific nonstructural panel types. Testing during development of the regulations confirmed PS 1 structural plywood readily meets the plywood emission limit; therefore the regulations explicitly exempt phenolic-bonded plywood from ongoing testing and certification. Therefore, the engineered wood products in Table 2 are either not covered by, or are explicitly exempt from, the HUD regulations.

2. California Air Resources Board (CARB) Airborne Toxic Control Measure (ATCM) for Composite Wood Products (also known as Title 17, California Code of Regulation 93120)

These regulations were developed by a division of the California EPA and took effect in 2009. The scope of the standard covers particleboard, MDF and hardwood plywood. The demonstrated low emission levels of the engineered wood products listed in Table 2 led the CARB regulations to explicitly exempt structural plywood specified to PS 1, structural panels specified to PS 2, OSB specified to PS 2, structural composite lumber specified to ASTM D5456, structural glued laminated timber specified to ANSI A190.1 and prefabricated wood I-joists specified to ASTM D5055. These exemptions apply to the product trademarked or audited by APA under the APA quality assurance program, regardless of whether the product is used in a construction application or in an industrial (manufacturing) application. Note that although CLT is not listed as an exempted product, CLT certified to ANSI/APA PRG 320 is made with moisture-resistant adhesives and has a low formaldehyde emission.

3. U.S. Formaldehyde Standards for Composite Wood Products Act (also known as EPA TSCA Title VI)

This Federal Act was signed into law in July 2010. The EPA published draft implementation rules in July 2016 for implementation of the law in 2018. The emission standard mirrors the standard established by the California Air Resources Board and it explicitly exempts structural plywood specified to PS 1, structural panels specified to PS 2, OSB specified to PS 2, structural composite lumber specified to ASTM D5456, structural glued-laminated timber specified to ANSI A190.1 and prefabricated wood I-joists specified to ASTM D5055, as trademarked or audited by APA under the APA quality assurance program. Note that although CLT is not listed as an exempted product, CLT certified to ANSI/APA PRG 320 is made with moisture-resistant adhesives and has a low formaldehyde emission.

4. Canadian Formaldehyde Emissions from Composite Wood Products Regulations

The Canadian government published the *Formaldehyde Emissions from Composite Wood Products Regulations* on June 17, 2021. The regulation comes into force 18 months afterward, and the requirements for laminated products will apply five years after the regulations come into force.

The regulations were developed following CARB and EPA TSCA Title VI to allow for uniform requirements for both the U.S. and Canada. Therefore, the Canadian regulations also do not apply to structural plywood specified to PS 1, CSA O121 or CSA O151; OSB specified to CSA O325 or PS 2; structural glued laminated timber specified to CAN/CSA O122 or ANSI A190.1; prefabricated wood I-joists specified to ASTM D5055; structural composite lumber, including laminated strand lumber (LSL), laminated veneer lumber (LVL), parallel strand lumber (PSL) and oriented strand lumber (OSL) specified to ASTM D5456; and cross-laminated timber (CLT) specified to ANSI/APA PRG 320. CSA O160, *Formaldehyde Emission Standard for Composite Wood Products*, is a voluntary standard providing the requirements for product sampling, emissions testing, marking and labeling for composite wood products in compliance with formaldehyde regulations in Canada.

International Regulations for Engineered Wood Products

Wood product standards in other countries often group structural and nonstructural panel types into a common standard, whereby the moisture resistance and formaldehyde emission characteristics are evaluated to specific criteria. Some North American engineered wood products have been evaluated to these international formaldehyde emission standards. Following are summary conclusions:

1. The Japanese Agricultural Standards (JAS) use the JIS A1460 test method that measures the emissions for wood products when enclosed in a desiccator. The most stringent formaldehyde limit is the F**** designation whereby the product must have average emission level below 0.30 mg/l. U.S. and Canadian structural plywood (PS 1, PS 2, CSA O121 or CSA O151), OSB (PS 2 or CSA O325), structural glued laminated timber (ANSI A190.1, CSA O177 or CSA O122) and structural composite lumber (ASTM D5456) easily and consistently meet the F**** requirements when evaluated to the respective JAS standard. This formaldehyde level is considered one of the most stringent limits in the world.
2. U.S. and Canadian OSB and plywood panels sold in Europe for construction uses must meet the specific product standard for the panel type (such as EN 300 for OSB and EN 636 for plywood) and the general panel standard EN 13986 used for construction applications throughout the European Union. The European standard for formaldehyde emissions is EN 717-1, which uses a one cubic meter chamber to measure emission levels. U.S. and Canadian structural plywood (PS 1, PS 2, CSA O121 or CSA O151) and OSB (PS 2 or CSA O325) easily meet the 0.124 mg/m³ limit of the E1 class, the most stringent formaldehyde class based on EN 717-1.
3. Laminated veneer lumber (LVL) is regulated in Australia by evaluation of formaldehyde emissions using the AS/NZS 4357.4 test method. This method is very similar to the JIS A1460 test method used in the JAS standards. U.S. and Canadian LVL made to ASTM D5456 has easily and consistently met the 0.5 mg/l limit, which qualifies it for the E0 rating, the most stringent rating in AS/NZS LVL standards.
4. The Korean Standard KS M 1998:2009 for determination of formaldehyde in building interior products is a method very similar to the JIS A1460 desiccator method. The most stringent formaldehyde limit for timber building products in Korea is the SE₀, with an average below 0.3 mg/l. U.S. and Canadian structural plywood (PS 1, PS 2, CSA O121 or CSA O151), OSB (PS 2 or CSA O325), structural glued laminated timber (ANSI A190.1, CSA O177 or CSA O122) and structural composite lumber (ASTM D5456) easily and consistently meet the SE₀ requirements when evaluated to methods similar to the Korean standard.

In summary, when tested to international formaldehyde emission limits, North American engineered wood products have consistently met the most stringent emission regulations.

Green Building Specifications

Green building rating systems often include criteria to address indoor air quality goals, including mitigation of formaldehyde concentrations or formaldehyde-emitting products. Some of these specifications are relevant to engineered wood products as follows:

1. U.S. Green Building Council (USGBC) LEED v4

This popular rating system uses a point rating system for green buildings. The indoor Environmental Quality Credit includes “Low-Emitting Materials—Composite Wood.” The criteria specifies products that meet the California Air Resources Board (CARB) Airborne Toxic Control Measure for Formaldehyde Requirements for Ultra Low-Emitting Formaldehyde (ULEF) Resins or “no added formaldehyde resin” (NAF). LEED Interpretation (LI) 10466 was issued to clarify the applicability of structural engineered wood products in the LEED v4 low-emitting materials credit. It also clarifies that the scope of California Department of Public Health (CDPH) Standard v1.1 does not apply to structural products. **Products specifically considered compliant as LEED low emitting materials include the referenced standards in Table 2 for structural plywood, oriented strand board, structural glued laminated timber, prefabricated wood I-joists, structural composite lumber and cross-laminated timber.**

2. National Green Building Standard ICC 700-2020

This national green rating program was developed as a consensus standard and adopted by the International Code Council as a reference standard for adoption by member code groups for residential construction. The criteria for formaldehyde emissions from composite wood products are similar to CARB. **The engineered wood products listed in Table 2 are eligible for the points in Section 901.4(5) which require that a minimum of 85 percent of material within the product group is manufactured from composite wood products that contain no added urea-formaldehyde or are in accordance with the CARB regulations.**

3. CALGreen

This standard has been adopted into California state building law as a method to verify structures meet state environmental goals for buildings. The 2019 edition of CALGreen requires all new buildings (residential and nonresidential) as well as all remodels and additions to existing nonresidential buildings exceeding 1,000 square feet or \$200,000 (Section 301.3 of CALGreen) must meet the mandatory requirements of CALGreen. CALGreen specifies that composite wood products used in the interior or the exterior of a building meet the CARB regulations. Similar to the CARB regulations, all structural engineered wood products are explicitly exempt from the requirement. **The engineered wood products in Table 2 are not within the scope of the CALGreen formaldehyde limits and are therefore permitted.**

4. The EPA Indoor airPLUS Program

The EPA Indoor airPLUS program is a voluntary partnership and labeling system that helps new home builders improve the quality of indoor air by requiring construction practices and product specifications that minimize exposure to airborne pollutants and contaminants. EPA created the Indoor airPLUS program to help builders meet the growing consumer preference for homes with improved indoor air quality. Indoor airPLUS builds on the foundation of EPA's ENERGY STAR® requirements for new homes and provides additional construction specifications to provide comprehensive indoor air quality protections in new homes. Section 6.1 of the Indoor airPLUS program provides information for composite wood. For structural plywood and OSB, the program prescriptively recognizes that PS 1 and PS 2 panels meet the requirements of the program.

References

Engineered Wood Product Standards

U.S. Voluntary Product Standard PS 1 Structural Plywood

U.S. Voluntary Product Standard PS 2 Performance Standard for Wood Structural Panels

ANSI A190.1 Structural Glued Laminated Timber

ANSI/APA PRP 210, Standard for Performance-Rated Engineered Wood Siding

ANSI 405 Standard for Adhesives for Use in Structural Glued Laminated Timbers

ANSI/APA PRG 320 Standard for Performance-Rated Cross-Laminated Timber

ANSI/APA PRR 410 Standard for Performance-Rated Engineered Wood Rim Boards

ASTM D2559 Standard Specification for Adhesives for Bonded Structural Wood Products for Use Under Exterior Exposure Conditions

ASTM D5055 Standard Specification for Establishing and Monitoring Structural Capacities of Prefabricated Wood I-Joists

ASTM D5456 Standard Specification for Evaluation of Structural Composite Lumber Products

ASTM D7247 Standard Test Method for Evaluating the Shear Strength of Adhesive Bonds in Laminated Wood Products at Elevated Temperatures

ASTM E1333 Standard Test Method for Determining Formaldehyde Concentrations in Air and Emission Rates from Wood Products Using a Large Chamber

CSA O112 Standards for Wood Adhesives

CSA O121 Canadian Douglas-fir Plywood

CSA O122 Structural Glued-Laminated Timber

Formaldehyde and Engineered Wood Products

CSA O151 Canadian Softwood Plywood

CSA O177 Qualification Code for Manufacturers of Structural Glued Laminated Timber

CSA O325 Construction Sheathing

Formaldehyde Emission Standards (for Wood Products)

AS/NZS 4357.4 Structural Laminated Veneer Lumber, Part 4: Determination of Formaldehyde Emissions

CSA O160 Formaldehyde Emission Standards for Composite Wood Products

EN 717-1 Wood-Based Panels, Determination of Formaldehyde Release, Formaldehyde Emission by the Chamber Method

JAS/JIS A 1460 Building Boards, Determination of Formaldehyde Emission—Desiccator Method

KS M 1998:2009 Determination of the Emission Rate of Formaldehyde and Volatile Organic Compounds in Building Interior Products

U.S. Formaldehyde Regulations

CALGreen: <https://www.dgs.ca.gov/BSC/CALGreen>

CARB: <https://ww2.arb.ca.gov/our-work/programs/composite-wood-products-program>

EPA Federal Act: <https://www.regulations.gov/document/EPA-HQ-OPPT-2016-0461-0001>

HUD: standard is available at www.gpo.gov/fdsys/pkg/CFR-2010-title24-vol1/content-detail.html
(search for cfr 3280, Manufactured Housing Construction Safety Standard)

Canadian Formaldehyde Regulations

Health Canada: <https://canadagazette.gc.ca/rp-pr/p2/2021/2021-07-07/html/sor-dors148-eng.html>

Formaldehyde Guidance

ACC website: www.formaldehydefacts.org

U.S. Consumer Product Safety Commission: <https://www.cpsc.gov/Regulations-Laws--Standards>

U.S. EPA: www.epa.gov/iaq/formaldehyde.html

U.S. EPA Integrated Risk Information System: <https://www.epa.gov/iris>

U.S. Green Building Council LEED Interpretation website: <https://www.usgbc.org/leed-interpretations>

U.S. Green Building Council website: <https://www.usgbc.org/>

SUBJECT: SIP SCREWS USED IN ACQ TREATED LUMBER

In 2004, the treated wood industry halted production of lumber pressure treated with Chromated Copper Arsenate (CCA) for residential applications in response to EPA concerns about arsenic (a known carcinogen). The primary product replacing CCA is Alkaline Copper Quaternary or ACQ. While ACQ is deemed safer because of its non-arsenic content, studies have shown it may be more corrosive to metal fasteners than CCA. The corrosive nature of ACQ and its impact on metal fasteners has created concern in the construction industry. Initial efforts by the manufacturers of ACQ treated lumber to identify acceptable metal fasteners resulted in the recommendation that stainless steel fasteners or hot-dipped galvanized fasteners be used with ACQ treated wood products.

Premier Building Systems also recommends that 8d nails used with Premier SIPS be stainless steel or hot-dipped galvanized fasteners when ACQ lumber is used. Considering the ACQ issue, Premier SIPS Wood Screws and Metal Fasteners have been evaluated by an independent third party to perform accelerated corrosion resistance tests in ACQ treated lumber. These independent test results indicate that Premier SIPS Wood Screws and Metal Fasteners barrier coatings perform well in ACQ treated lumber and even outperform hot-dipped galvanized fasteners. As a result of these performance tests, Premier SIPS can recommend that Premier SIPS Wood Screws and Metal Fasteners are “compatible for ACQ” treated wood applications.

As with any fastener in an ACQ treated lumber application, estimates of its service life cannot be provided due to the many variables that the fastener is exposed to, including (but not limited to) the chemical retention level in the wood, species of wood and environment.

Note: Premier SIPS Wood Screws and Metal Fasteners are intended for use with Premier SIPS as described in the Premier SIPS details and are not intended for other applications.

Current Premier SIPS Details, and additional Technical Bulletins with different Screw and Nail Properties can be found at www.premiersips.com.

SUBJECT: PREMIER SIPS ENGINEERING PROPERTIES

Premier SIPS are recognized as a structural component for use as wall, roof, or floor panels that resist structural loads. The structural capacity of Premier SIPS has been determined through extensive testing with leading independent third-party accredited testing laboratories. The results of these tests have published in Premier SIPS Load Charts and recognized in ICC ES ESR-4524, ESL-1207 and ESL-1208.

The complete package of structural information that supports Premier SIPS Load Charts #3A and #6A have been analyzed and reviewed to provide basic SIP Engineering Properties for Premier SIPS. These Premier SIPS Engineering Properties (See Tables 1 and 2 on this Technical Bulletin) are suitable for use with NTA IM 14 TIP 01, “Engineered Design of SIP Panels using NTA Listing Report Data.” A copy of NTA IM 14 TIP 01, as well as all current Premier SIPS Load Charts can be accessed at www.premiersips.com.

TABLE 1: PREMIER SIPS ENGINEERING ^{1,2}	
Property	Value ³
Facing Tensile Strength, F_t (psi)	495
Facing Compressive Strength, F_c (psi)	550
Elastic Modulus (Bending), E_b (psi)	1,677,107
Shear Modulus, G (psi)	284
Core Shear Strength, F_v (psi)	4.7
Core Compressive Modulus, E_c (psi)	400
Shear Reference Depth, h_o (in.)	4.5
Shear Depth Factor Exponent, m	0.59
Face-peeling Factor, C_p	0.975
Apparent Foam Compression Strength (psi)	21

¹ All properties are based on a minimum panel width of 24-in.

² Refer to NTA IM14 TIP 01 SIP Design Guide for details on engineered design using basic properties.

³ Values apply to panels constructed with the OSB strength axis oriented either parallel or perpendicular to supports.

TABLE 2: PREMIER SIPS SECTION PROPERTIES

Panel Thickness, h (in.)	Core Thickness, c (in.)	Dead Weight, W_d (psf)	Facing Area, A_f (in. ² /ft.)	Shear Area, A_v (in. ² /ft.)	Moment of Inertia, I (in. ⁴ /ft.)	Section Modulus, S (in. ³ /ft.)	Radius of Gyration, r (in.)	Centroid -to- Facing Dist., y_c (in.)
4.5	3.63	3.2	10.5	48.8	43.3	19.3	2.03	2.25
6.5	5.63	3.4	10.5	72.8	96.5	29.7	3.03	3.25
8.25	7.38	3.5	10.5	93.8	160.2	38.8	3.91	4.13
10.25	9.38	3.7	10.5	117.8	252.7	49.3	4.91	5.13
12.25	11.38	3.9	10.5	141.8	366.3	59.8	5.91	6.13

SUBJECT: HVAC DESIGN AND ENERGY CALCULATIONS

HVAC professionals require substantiated design information to properly select the mechanical systems installed in Premier SIPS residential projects. HVAC professionals rely on ACCA (Air Conditioning Contractors of America) Manual J as the design guide to calculate the requirements for the heating and cooling systems in residential structures. These Manual J calculations are computer software based and have defaults for R-value and air changes per hour (ACH). However, if a proper evaluation of a home built with SIPs is to be accurate, the HVAC professional needs to manually input the following two factors to arrive at a meaningful result: Premier SIPS higher R-value and air tightness.

Premier SIPS energy savings can be attributed to two main factors:

1. Increased stable R-value do to the high performance rigid insulation core
2. Lowered air infiltration due to few and tighter joints on the envelope.

Manual J based calculations require the R-value of the insulation material and the air infiltration rate, or air leakage rate. The R-value of Premier SIPS needs to be manually inputted into Manual J calculations based on their Whole Wall R-value. Additionally, the air infiltration rate for Premier SIPS must be accounted for properly. Design guidelines for Manual J calculations suggest a reasonable air leakage assumption between 0.35 to 0.50 natural air-changes per hour at 50 pascals. This recommendation is for stick-built homes.

Premier Building Systems has blower door test data generated from homes using SIPs for the exterior walls and roof of homes that tested between .04 to .06 ACH. These SIP home ACH values are on the order of 10 times better than what the Manual J design guidelines suggest for natural air changes per hour.

Therefore, based on Premier SIPS achieving verified ACH test values between 0.04 to .06, Premier recommends that a value of .05 natural air changes per hour be used when performing Manual J heat loss calculations on homes using Premier SIPS as the exterior walls and roof. If the software being used does not allow for numerical input, select the tightest option possible.

Applying Manual J calculations provides for the increased R-value and the reduced air infiltration of buildings constructed with SIPs. These two factors will allow for down-sizing/right sizing of the heating and cooling equipment. This will provide initial cost savings at the time of construction. In addition right-sizing of the HVAC system will provide a more comfortable environment for the occupants.

Architects/engineers, builders, building owners and other building professionals have learned from experience that energy savings for a well-built Premier SIPS structure can be 30 to 50%, or more.

FRESH AIR VENTILATION OF SIP STRUCTURES

Reducing air leaks in a structure is central to achieving maximum energy and clean air performance. Many building strategies such as house wraps, vapor retarders, rigid insulation sheathing, tapes and sealants are designed to reduce air leakage. Premier SIPS are one of the best building systems available to provide low air leakage and overall building energy efficiency. Moisture, fumes from adhesives, smoking and other gases and particulates can become trapped within the structure. When these pollutants accumulate to high levels, they could potentially contribute to an unhealthy living environment. Heat Recovery Ventilators (HRVs) and Energy Recovery Ventilators (ERVs) allow a structure to remain efficient while also providing fresh air at a low operating cost. Indoor air pollutants are continuously being taken away and replaced with fresh air. This provides a healthier living environment while retaining energy savings.

A brief synopsis of how HRVs and ERVs work to effectively improve indoor air quality follows:

HRVs and ERVs are mechanical units that can continually exchange stale inside air for fresh outside air, while also using the heat (or cold) from the exhaust air to raise or lower the temperature of the incoming air. A large percentage of the heat in the exhausted air can be recaptured. This efficiency allows a constant flow of fresh air and doesn't require a separate heating unit to heat the incoming fresh air. ERVs work in a similar manner regarding heat recovery, but also allow the building owner to control inside humidity.

WHAT INSTALLATION IS REQUIRED?

HRVs and ERVs require some planning before construction. The main unit should be placed in a temperature - controlled area, a basement, mechanical room, etc. Ductwork is typically run from rooms such as bathrooms, laundries and kitchens to the HRV or ERV unit. These areas are chosen for their typically high levels of odor and humidity. Insulated ductwork is then run from the HRV or ERV to the exterior of the building. A separate system of fresh air ductwork is run from the exterior of the building to the unit and continued to the fresh air drop, often return air duct of a furnace.

HOW DO HRVS AND ERVS WORK?

Stale air is drawn from the bath, laundry and kitchen to the HRV or ERV, and is ducted through the HRV or ERV to the outdoors. Meanwhile, fresh outside air is drawn into the HRV or ERV, then ducted to the inside fresh air drop point. As the two separate streams of air pass each other within the HRV or ERV, they are separated by a medium that provides a conductor for the heat to be exchanged from the hot air to the cold air. The incoming fresh air is warmed by the transfer of heat from the inside air and is then ducted into the living area or furnace air supply. Excessive summertime moisture can be controlled with an ERV. As the air streams pass the medium, condensation will appear on the exhaust side of the medium.

The condensation forms because the warm moisture-laden exhaust air cannot hold as much moisture after its heat has been drawn through the medium. The condensed moisture is removed and drained away. Conversely, the ERV can be set to retain interior moisture in the winter months of operation.

WHERE SHOULD I USE AN HRV OR AN ERV?

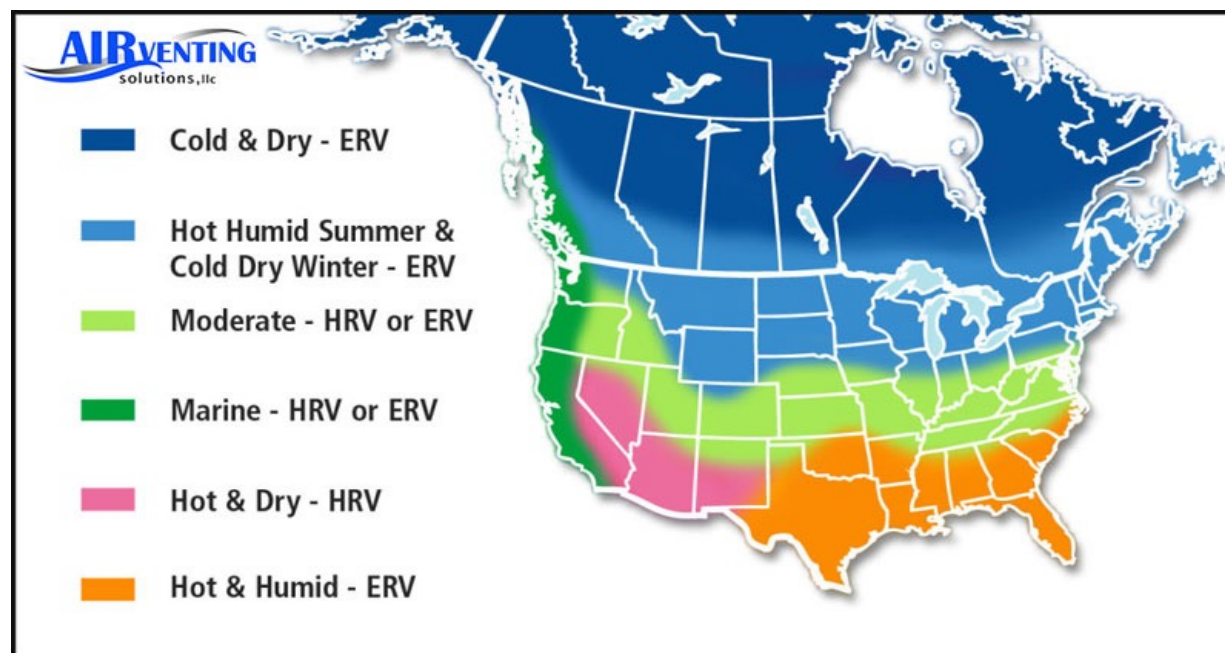

NOTE: Map prepared by Air Venting Solutions, LLC at www.airventingsolutions.com.

It is recommended that the humidity level in a SIP structure should be controlled to <40% in winter and <60% in summer. Higher levels of moisture could lead to condensation problems. Please consult a local HVAC engineer and contractor, or reference ASHRAE (American Society of Heating, Refrigerating and Air Conditioning Engineers) standards for the design and installation of HRVs and ERVs as part of a complete HVAC design.

ADDITIONAL RESOURCES:

National Center for Appropriate Technology
P.O. Box 2525
Butte, Montana
Ph: 800-428-2525

Energy Efficiency and Renewable Energy Clearinghouse
P.O. Box 3048
Merrifield, VA
Ph: 800-DOE-EREC

SUBJECT: POINT LOADING WALLS

Premier SIPS walls are used in combination with various types of roof and floor designs. For roof systems, these include rafter and ridge beams to carry the roof SIPs, roof trusses, girder trusses and girder truss beams. For floor systems, collection beams and girder trusses are often used in larger open rooms. Roof and floor systems using the load collection methods described above, often result in the need to transfer a point load from the roof or floor system uniformly onto the wall. Premier has evaluated the point load capacity of SIPs as shown in the Premier SIPS Load Chart #2A (See below).

The total load should never exceed the lesser of the point load capacity or the SIPs axial and transverse capacity shown on the Premier SIPS Wall-Point Load Chart. If the design load exceeds these point loads, Premier SIPS can be fabricated to accept a variety of posting methods, as determined by the engineer of record (EOR).

LOAD CHART #2A Axial Point Loads - LBS ¹⁻² Type S Spline		
Top Plate Configuration	1-1/2" BEARING WIDTH	3" BEARING WIDTH
Single 2x No. 2 or better Hem-Fir Plate	2040	2450
Single 2x No. 2 or better Hem-Fir Plate with 2x No. 2 or Better Cap Plate Ripped to Total Width of SIP.	4030	4678

¹ Permanent loads, such as dead load, shall not exceed 0.50 times the tabulated load.

² Tabulated values are based on the strong-axis of the facing material oriented parallel to the span direction.

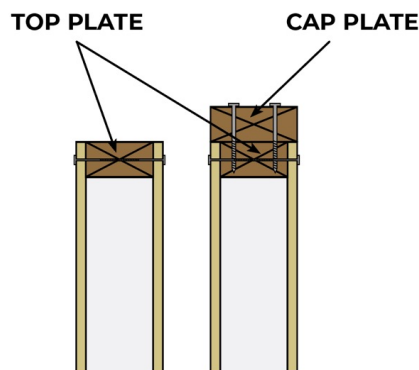

Beams may also be pocketed into the SIP wall assembly per detail PBS-415. This detail provides for an aesthetically pleasing interface between the wall and the support mechanism for roofs and floors.

When this detail is used with Premier SIPS, the following recommendations should be followed:

1. Loads for detail PBS-415 shown above are limited to the point loads established in the Premier SIPS Resource Manual. Basically, this calls for a maximum design load of 2450 pounds for a standard 2x plate used in the panel under the beam. The use of an abbreviated cap plate placed above the base of the beam pocket and extending over the OSB facings does not allow for increased loads in this application. When loads exceed 2450 pounds, posting is required under the beam per detail PBS-414.
2. This detail provides for a thermal short circuit in the wall panel system. Great care should be taken to seal this joint. After sealants are placed in the pocket all interior interfaces must be further sealed with Premier SIPS Tape.
3. Maximum design loads can be compromised if the beam pocket is over cut at the corner of the pocket. Good craftsmanship is required to assure that the pocket is not over cut in the corners.

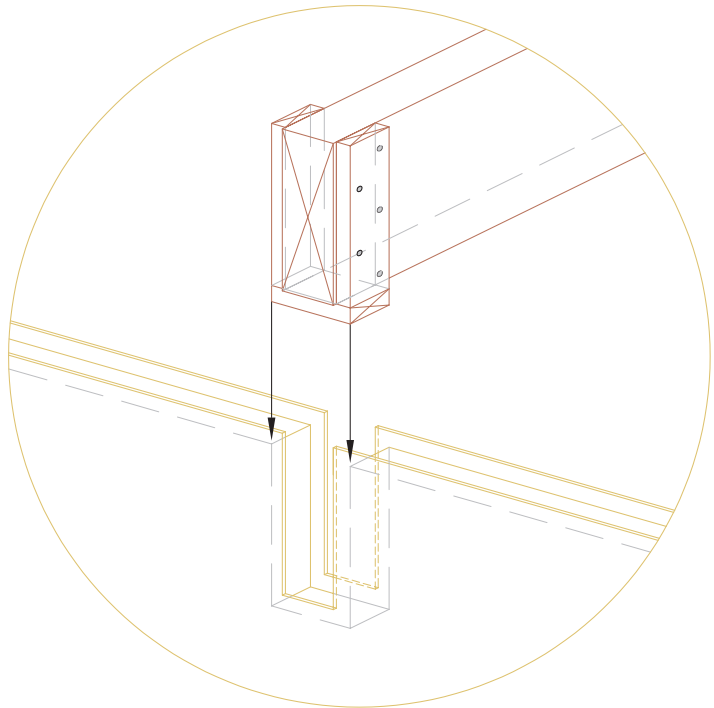

SUBJECT: PREMIER SIPS WALL LOADS (COMBINED AXIAL & TRANSVERSE LOADING)

Building materials that are utilized to create structural components, such as walls, are subject to a combination of loads. Wall assemblies must be able to withstand axial forces, while at the same time resisting a bending load. Most building materials, including concrete, steel, lumber and other engineered wood products determine their acceptability for application in an assembly using a well-known engineering formula known as the Unity Equation.

The Unity Equation considers the ultimate load capacity for a product in both the axial and transverse directions. These ultimate loads are divided by a factor of safety which yields design values. In determining if a wall assembly meets the required combined axial and transverse loads, the wall assembly must meet the following formula:

$$\left(\frac{f_a \text{ (Design Axial Load)}}{F_a \text{ (Allowable Axial Load)}} \right) + \left(\frac{f_b \text{ (Design Bending Load)}}{F_b \text{ (Allowable Bending Load)}} < 1 \right)$$

Reference Load Chart #1A / #1B for uniform axial load values for type S / type L splines and Load Chart #3A for uniform transverse loads for the data necessary to complete the Unity Equation.

All Current Load Charts are available at www.premersips.com.

LOAD CHART #1A Uniform Axial Loads - PLF ¹⁻⁴ Type S Spline						
SIP Thickness	SIP Height (ft.)					
	8'	10'	12'	16	20'	24'
4-1/2"	3500	2553	2453	2117	NA	NA
6-1/2"	4250	4043	3373	3923	2817	2183
8-1/4"	4917	4327	4473	4197	3497	3067
10-1/4"	4600	4414	4228	4417	3389	3248
12-1/4"	3889	3959	4028	4408	3837	3333

¹ Permanent loads, such as dead load, shall not exceed 0.50 times the tabulated load.

² Uniform axial loads.

³ Both facings must bear on the supporting foundation or structure.

⁴ Tabulated values for 8-foot (2.44 m) walls apply to SIPs constructed with OSB strength axis oriented either parallel or perpendicular to supports.

AXIAL LOAD

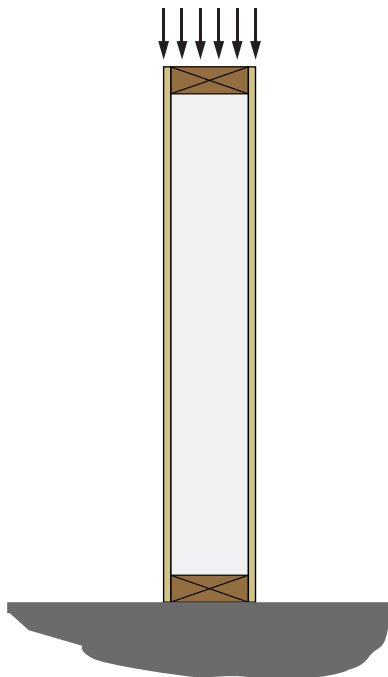

TYPE S SPLINE

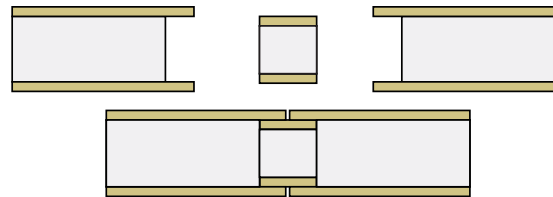

LOAD CHART #1B						
Uniform Axial Loads - PLF ¹⁻⁴						
Type L Spline						
SIP Thickness	SIP Height (ft.)					
	8'	10'	12'	16'	20'	24'
4-1/2"	4723	3903	3273	2623	NA	NA
6-1/2"	5850	5890	4277	4310	2933	2837
8-1/4"	6807	6110	5557	5180	4837	4083
10-1/4"	5473	5709	5946	5948	4729	4250
12-1/4"	5667	5474	5281	5775	4729	4223

¹ Splines consist of No. 2 or better, Hem-Fir, 1-1/2 inch (38.1 mm) wide with depth equal to the core thickness, spaced to provide no less than two members for every 48 inches (1219.2 mm) of SIPs width. Permanent loads, such as dead load, shall not exceed 0.50 times the tabulated load.

² Uniform axial loads.

³ Both facings must bear on the supporting foundation or structure.

⁴ Tabulated values for 8-foot (2.44 m) walls apply to SIPs constructed with OSB strength axis oriented either parallel or perpendicular to supports.

AXIAL LOAD

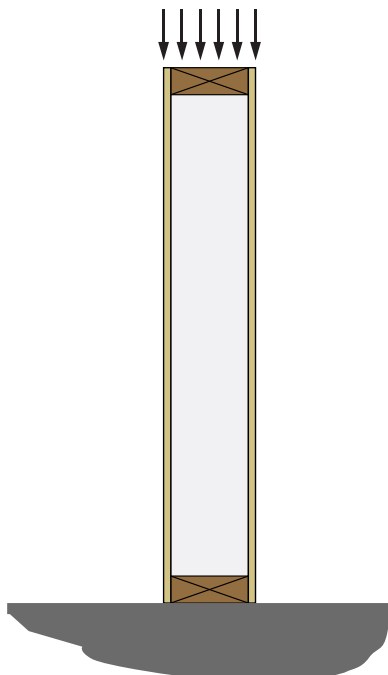

TYPE L SPLINE

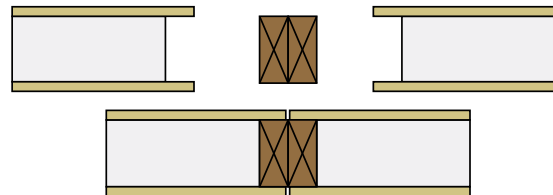

LOAD CHART #3A										
Wall Uniform Transverse Loads - PSF ¹⁻³										
Type S Spline										
SIP Thickness	Deflection Limit	SIP Height (ft.)								
		8'	10'	12'	14'	16'	18'	20'	22'	24'
4-1/2"	L/360	32	23	18	14	11	NA	NA	NA	NA
	L/240	48	35	27	21	16	NA	NA	NA	NA
	L/180	55	44	36	28	22	NA	NA	NA	NA
6-1/2"	L/360	51	38	29	23	19	15	12	NA	NA
	L/240	67	53	44	35	28	23	19	NA	NA
	L/180	67	53	44	38	33	29	24	NA	NA
8-1/4"	L/360	67	51	40	32	26	22	18	15	13
	L/240	75	60	50	42	37	33	27	23	19
	L/180	75	60	50	42	37	33	30	26	22
10-1/4"	L/360	83	66	52	43	35	29	25	21	18
	L/240	83	66	55	47	41	36	33	30	27
	L/180	83	66	55	47	41	36	33	30	27
12-1/4"	L/360	89	72	60	51	44	37	32	27	23
	L/240	89	72	60	51	45	40	36	32	30
	L/180	89	72	60	51	45	40	36	32	30

¹ Permanent loads, such as dead load, shall not exceed 0.50 times the tabulated load.

² Deflection limit shall be selected by building designer based on the serviceability requirements of the structure and the requirements of applicable building code. Values are based on loads of short duration only.

³ Table values for 8-foot (2.44 m) spans apply to SIPs constructed with the OSB strength axis oriented either parallel or perpendicular to span direction. Table values for other spans are based on the OSB strength axis parallel to the span direction..

TRANSVERSE LOAD

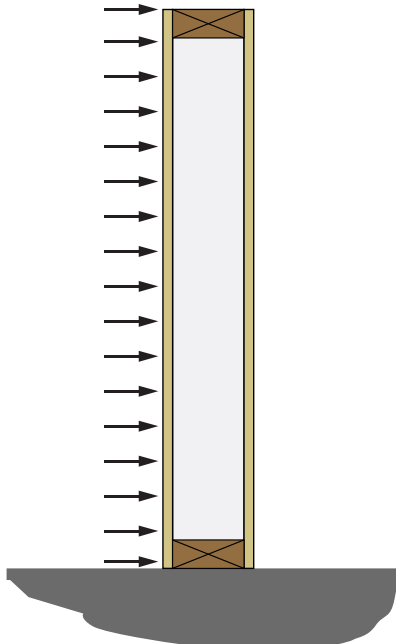

TYPE S SPLINE

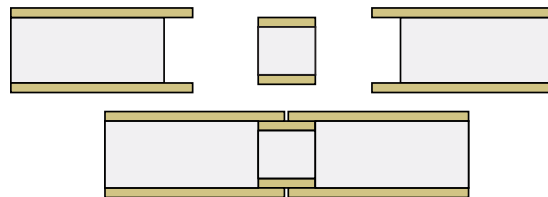

SUBJECT: SHEAR WALL & DIAPHRAGM CAPACITY OF PREMIER SIPS

Premier SIPS have been evaluated for use as shear walls and diaphragms in structures. Shear wall and diaphragm applications include both wall and roof assemblies that are subjected to seismic or wind loads. Through large and small-scale testing conducted at the APA laboratories, overseen by an independent structural consultant, it was determined that Premier SIPS can develop design diaphragm capacities of up to 850 lbs./ft. Please refer to the Premier SIPS Load Chart #7A for Premier SIPS Wood Screw and nail spacing required to obtain this capacity.

These tests have allowed for the determination of design capacities for Premier SIPS Wood Screws and nails when used in diaphragms. The following lateral load capacities are recommended:

- Premier SIPS Wood Screws: 250 lbs.
- 8d nails @ surface splines: 62.5 lbs.

DESIGN VALUES INCLUDE A SAFETY FACTOR OF THREE ON THE ULTIMATE LOAD.

In all shear wall and diaphragm applications, the design of the lateral load resisting system must be engineered to provide a load path for the forces that the structure experiences. This is provided by the engineer of record on the specific project.

Current Premier SIPS Load Charts and the Premier SIPS Resource Manual can be found at www.premiersips.com.

LOAD CHART #7A						
Roof/Floor Diaphragms Loads - PLF ^{1, 5} • Type S Spline						
Minimum Connections ²				Allowable Shear Load (PLF)	G' Apparent Shear Stiffness (lbf/in)	Maximum Aspect Ratio
Interior Supports ²	Spline ³	Boundary ⁴				
		Support	Spline			
PBS No. 14 SIP Screw with 1" penetration 12" on center	0.113"x 2-1/2" nails, 3" on center 7/16" x 3" OSB Box/Block Spline	PBS No. 14 SIP Screw with 1" penetration 12" on center	0.113" x 2-1/2" nails, 6" on center	430	24000	4:1
PBS No. 14 SIP Screw with 1" penetration 12" on center	0.113"x 2-1/2" nails, 3" on center, 2 rows, staggered 7/16" x 3" OSB Box/Block Spline	PBS No. 14 SIP Screw with 1" penetration 3" on center	0.113" x 2-1/2" nails, 4" on center	460	30300	4:1
PBS No. 14 SIP Screw with 1" penetration 2" on center	0.113"x 2-1/2" nails, 3" on center, 2 rows, staggered 7/16" x 3" OSB Box/Block Spline	PBS No. 14 SIP Screw with 1" penetration 2" on center	0.113" x 2-1/2" nails, 1-1/2" on center	655	41300	4:1
PBS No. 14 SIP Screw with 1" penetration 4" on center	0.113"x 2-1/2" nails, 3" on center, 2 rows, staggered 7/16" x 3" OSB Box/Block Spline	PBS No. 14 SIP Screw with 1" penetration 4" on center	0.113" x 2-1/2" nails, 3" on center	795	93700	3:1
PBS No. 14 SIP Screw with 1" penetration 4" on center	0.113"x 2-1/2" nails, 6" on center, 2 rows, staggered 23/32" x 4" OSB Box/Block Spline	PBS No. 14 SIP Screw with 1" penetration 4" on center	0.113" x 2-1/2" nails, 6" on center	1130	110600	3:1

- ¹ The maximum diaphragm length-to-width ratio shall not exceed 4: 1. Load may be applied parallel to continuous panel joints.
- ² Interior supports shall be spaced not to exceed 12 feet (3.66 m) on center and have a minimum width of 3-1/2 inches (88.9 mm) and a specific gravity of 0.42 or greater. Specified fasteners are required on both sides of panel joint where panels are joined over a support. See Figure 4A.
- ³ Box/Block Spline fastened at top only, at interior panel-to-panel joints. Specified fasteners are required on both sides of panel joint. See Figure 4B.
- ⁴ Boundary spline shall be solid 1-1/2 inches (38.1 mm) wide, minimum, and have a specific gravity of 0.42 or greater. Boundary supports shall have a minimum width of 3-1/2 inches (88.9 mm) and a specific gravity of 0.42 or greater. Specified spline fasteners are required through both facings. See Figure 4C.
- ⁵ Diaphragms shall be designed by a registered design professional in accordance with accepted engineering practice.

DIAPHRAGM LOAD

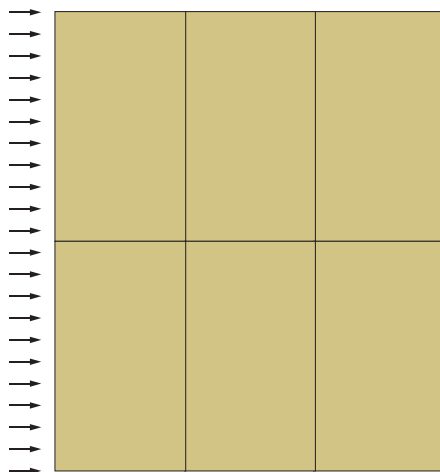

TYPE S SPLINE

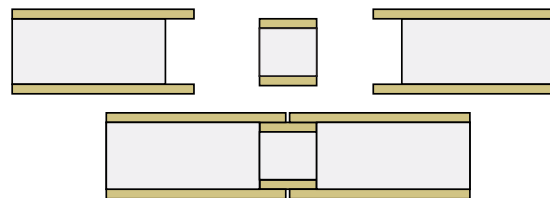

LOAD CHART #4A				
Shear Loads - PLF¹⁻⁷ Seismic Design Categories A-C				
Type S or Type L Spline				
Framing Minimum SG	Minimum Facing Connections ⁴			Shear Load (PLF)
	Chord ^{4,5}	Plate	Spline	
0.50	0.113"x 2-1/2" nails 6" on center	0.113"x 2-1/2" nails 6" on center	(7/16" OSB Faced x 3" wide Box/Block Spline) 0.113"x 2-1/2" nails, 6" on center	410
0.50	0.113"x 2-3/8" nails 6" on center Staggered (2 rows)	0.113"x 2-3/8" nails 6" on center	(7/16" OSB Faced x 3" wide Box/Block Spline) 0.113"x 2-3/8" nails, 6" on center ⁶	460
0.42	0.113"x 2-3/8" nails 6" on center Staggered (2 rows)	0.113"x 2-3/8" nails 4" on center Staggered (2 rows)	(7/16" OSB Faced x 3" wide Box/Block Spline) 0.113"x 2-3/8" nails, 4" on center ⁶	700
0.42	0.148"x 2-3/8" nails 6" on center Staggered (2 rows)	0.148"x 2-3/8" nails 3" on center	(23/32" OSB Faced x 3" wide Box/Block Spline) 0.148"x 2-3/8" nails, 3" on center stagger (2 rows) ⁷	1000

¹ Wind and seismic loads in seismic design categories A, B, C.

² Aspect ratio (height:width) does not exceed 2:1.

³ Shear wall height-width ratios greater than 2:1, but not exceeding 3.5:1, are permitted for assemblies using lumber splines provided the allowable shear strength values in the table are multiplied by 2w/h.

⁴ Required connections must be made on each side of the SIPs. Dimensional or engineered lumber shall have an equivalent specific gravity not less than specified.

⁵ Chords, hold-downs and connections to other structural elements must be designed by a registered designer professional in accordance with accepted engineering practice.

⁶ 4 inch (101.6 mm) wide spline.

⁷ 4 inch (101.6 mm), 23/32 inch (18.25 mm) thick facing.

SHEAR LOAD

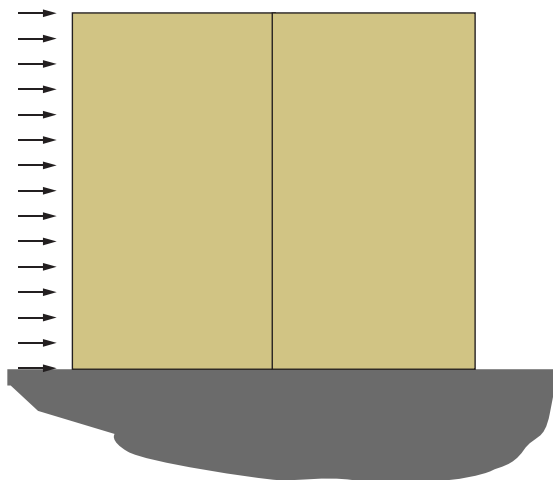

TYPE S SPLINE

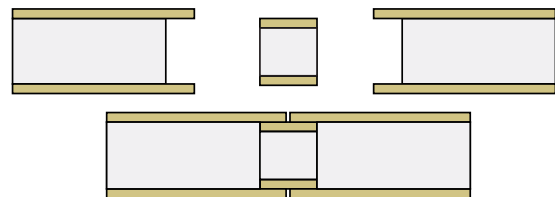

TYPE L SPLINE

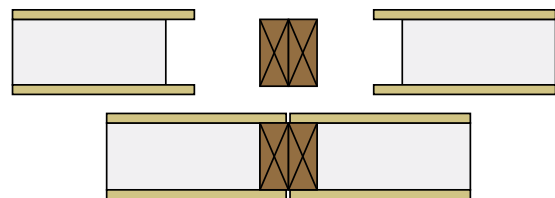

SUBJECT: PREMIER SIPS USED IN FLOOR APPLICATIONS

Premier SIPS are often used in floor applications when an insulated floor system is required. Examples of this situation are over a non-conditioned crawl space, the floor of a sunroom addition, or a bedroom floor over an unheated garage.

When using Premier SIPS in floor applications, there are a few design considerations to keep in mind. Premier recommends that the floor panel be overlaid with an additional layer of 7/16" sheathing to minimize any potential for puncturing of the SIPS structural skins, and to provide a divorcement layer to protect structural integrity of SIP should flooring need to be replaced. The application of these divorcement materials will obviate any damage to the top OSB structural facing of the SIP if the floor finishing were to need replacing. The OSB facings of a SIP are part of the SIP's structural component assembly, therefore the OSB facings must remain intact to provide long term structural capacity.

Floor SIPs, without added spline structure, e.g., Type I and Type L Splines, are not able to support load bearing walls and cannot be cantilevered over a lower wall to support an upper wall and roof systems. Please consult the Premier SIPS Load Charts for Type I Splines and Type L Splines. The load limitations, of SIPs used in floor systems, are covered by Premier SIPS Load Charts #6a, #6b, #6c, and other technical bulletins.

Building codes have specific requirements for materials used to create floor assemblies. In residential applications, the floor system must be able to carry a uniform load of 40 psf. Commercial floor assemblies, such as those found in churches, schools, banks, hotels, etc., have more stringent requirements. These include the capacity to support uniform loads greater than 40 psf and the ability to support concentrated loads. The concentrated load requirement for most commercial structures is 1000 or 2000 pounds over a 30" x 30" (6.25 sq. ft.) area.

Two typical Premier SIPS floor assemblies have been subjected to concentrated floor load testing. The results from this testing demonstrate that Premier SIPS floor assemblies meet the code requirement for commercial floors of 2000 pound concentrated loads, while providing a safety factor of three.

Load charts #6A, 6B & 6C (Pages 2-4) demonstrate the load capacities for floor design applications. View on the following pages or at www.premiersips.com.

LOAD CHART #6A											
Roof/Floor Uniform Transverse Loads - PSF ¹⁻⁴											
Type S Spline											
SIP Thickness	Deflection Limit	SIP Span (ft.)									
		4' ⁴	8'	10'	12'	14'	16'	18'	20'	22'	24'
4-1/2"	L/360	100	32	23	NA	NA	NA	NA	NA	NA	NA
	L/240	143	48	35	NA	NA	NA	NA	NA	NA	NA
	L/180	143	63	47	NA	NA	NA	NA	NA	NA	NA
6-1/2"	L/360	105	51	38	29	23	NA	NA	NA	NA	NA
	L/240	162	76	57	44	35	NA	NA	NA	NA	NA
	L/180	191	80	61	50	42	NA	NA	NA	NA	NA
8-1/4"	L/360	120	67	51	40	32	26	22	NA	NA	NA
	L/240	179	94	71	57	48	40	33	NA	NA	NA
	L/180	179	94	71	57	48	41	36	NA	NA	NA
10-1/4"	L/360	131	86	66	52	43	35	29	25	21	NA
	L/240	168	94	75	63	54	47	41	36	32	NA
	L/180	168	94	75	63	54	47	41	36	33	NA
12-1/4"	L/360	132	94	75	63	53	44	37	32	27	23
	L/240	163	94	75	63	54	47	42	37	34	31
	L/180	163	94	75	63	54	47	42	37	34	31

¹ Table values assume a simply supported SIP with 1-1/2 inches (38.1 mm) of continuous bearing. Permanent loads, such as dead load, shall not exceed 0.50 times the tabulated load. Values do not include the dead weight of the SIP.

² Deflection limit shall be selected by building designer based on the serviceability requirements of the structure and the requirements of applicable building code. Values are based on loads of short duration only and do not consider the effects of creep.

³ Table values for 8-foot (2.44 m) spans apply to SIPs constructed with the OSB strength axis oriented either parallel or perpendicular to span direction. Table values for other spans are based on the OSB strength axis parallel to the span direction.

⁴ SIPs shall be a minimum of 8-foot (2.44 m) long spanning two 4-foot (1.22 m) spans.

TRANSVERSE LOAD

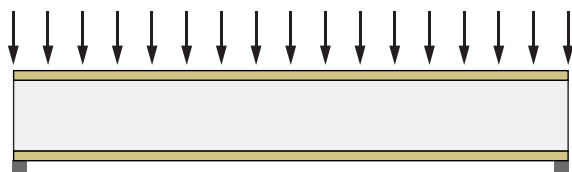

TYPE S SPLINE

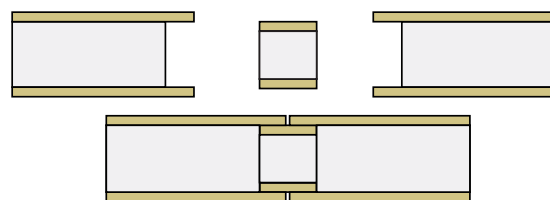

LOAD CHART #6B											
Roof/Floor Uniform Transverse Loads - PSF¹⁻⁴											
Type I Spline											
SIP Thickness	Deflection Limit	SIP Span (feet)									
		4 ⁴	8	10	12	14	16	18	20	22	24
10-1/4"	L/360	197	164	124	72	67	61	48	34	29	24
	L/240	336	164	124	107	96	84	70	49	43	36
	L/180	336	164	124	107	96	84	76	65	56	47
12-1/4"	L/360	258	143	103	86	83	77	61	42	37	32
	L/240	318	143	103	93	85	77	68	59	54	46
	L/180	318	143	103	93	85	77	68	59	54	49

- ¹ Table values assume a simply supported SIP with 1-1/2 inches (38.1 mm) of continuous bearing. Permanent loads, such as dead load, shall not exceed 0.50 times the tabulated load. Splines consist of Premier I-beam, 2-1/4 inch (57.2 mm) wide flange (minimum) with a depth equal to the core thickness, spaced not to exceed 48 inches (1219.2 mm) on center.
- ² Deflection limit shall be selected by building designer based on the serviceability requirements of the structure and the requirements of applicable building code.
- ³ Table values for 8-foot (2.44 m) spans apply to SIPs constructed with the OSB strength axis oriented either parallel or perpendicular to span direction. Table values for other spans are based on the OSB strength axis parallel to the span direction.
- ⁴ SIP shall be a minimum of 8 foot (2.44 m) long spanning a minimum of two 4-foot (1.22 m) spans.

TRANSVERSE LOAD

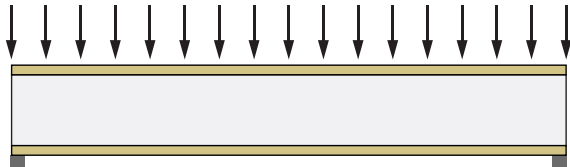

TYPE I SPLINE

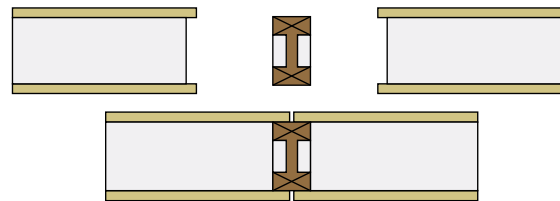

LOAD CHART #6C											
Roof/Floor Uniform Transverse Loads - PSF ¹⁻⁴											
Type L Spline											
SIP Thickness	Deflection Limit	SIP Span (feet)									
		4 ⁴	8	10	12	14	16	18	20	22	24
4-1/2"	L/360	103	45	33	24	NA	NA	NA	NA	NA	NA
	L/240	225	68	47	34	NA	NA	NA	NA	NA	NA
	L/180	297	91	61	45	NA	NA	NA	NA	NA	NA
6-1/2"	L/360	307	129	57	42	34	25	20	NA	NA	NA
	L/240	307	182	87	61	49	37	30	NA	NA	NA
	L/180	307	182	112	80	65	49	39	NA	NA	NA
8-1/4"	L/360	253	171	82	66	54	41	32	23	NA	NA
	L/240	288	188	128	100	81	61	48	35	NA	NA
	L/180	288	188	133	117	105	80	63	45	NA	NA
10-1/4"	L/360	286	188	117	101	80	58	47	36	32	27
	L/240	326	188	147	134	120	90	71	52	47	41
	L/180	326	188	147	134	121	106	93	68	61	53
12-1/4"	L/360	327	188	167	141	116	91	75	58	47	36
	L/240	327	188	167	153	132	110	97	83	69	53
	L/180	327	188	167	153	132	110	97	83	83	70

- ¹ Table values assume a simply supported SIP with 1-1/2 inches (38.1 mm) of continuous bearing. Permanent loads, such as dead load, shall not exceed 0.50 times the tabulated load. Splines consist of No. 2 or better Hem-Fir, 1-1/2 inches (38.1 mm) wide with a depth equal to the core thickness, spaced to provide not less than two members for every 48 inches (1219.2 mm) of SIP width.
- ² Deflection limit shall be selected by building designer based on the serviceability requirements of the structure and the requirements of applicable building code.
- ³ Table values for 8-foot (2.44 m) spans apply to SIPs constructed with the OSB strength axis oriented either parallel or perpendicular to span direction. Table values for other spans are based on the OSB strength axis parallel to the span direction.
- ⁴ SIP shall be a minimum of 8 foot (2.44 m) long spanning two 4-foot (1.22 m) spans. No single span condition is allowed.

TRANSVERSE LOAD

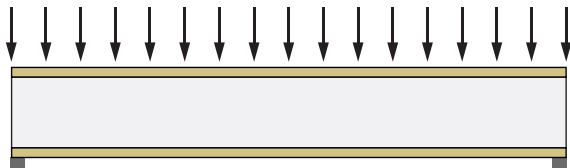

TYPE L SPLINE

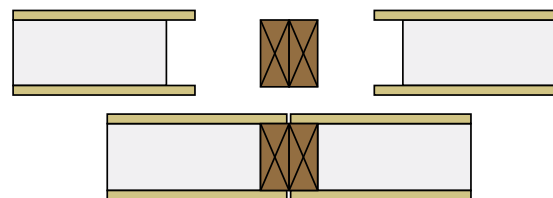

SUBJECT: WIND SPEED VS. PRESSURE

The building codes have set forth minimum design criteria that must be met in the structural design of a building. These criteria are for both gravity and lateral loading. The purpose of this technical bulletin is to touch on the requirements for designing structures to resist wind loads.

Both the IRC and the IBC reference ASCE 7 to determine design wind pressures for a structure. ASCE 7 has three methods for determining wind loads on structures. This technical bulletin uses the simplified procedure to create the following chart as an aide in estimating a structure's design wind load requirement. This chart is not intended to be used for the final structural design of the structure. Your design professional will need to determine the final design for your specific project.

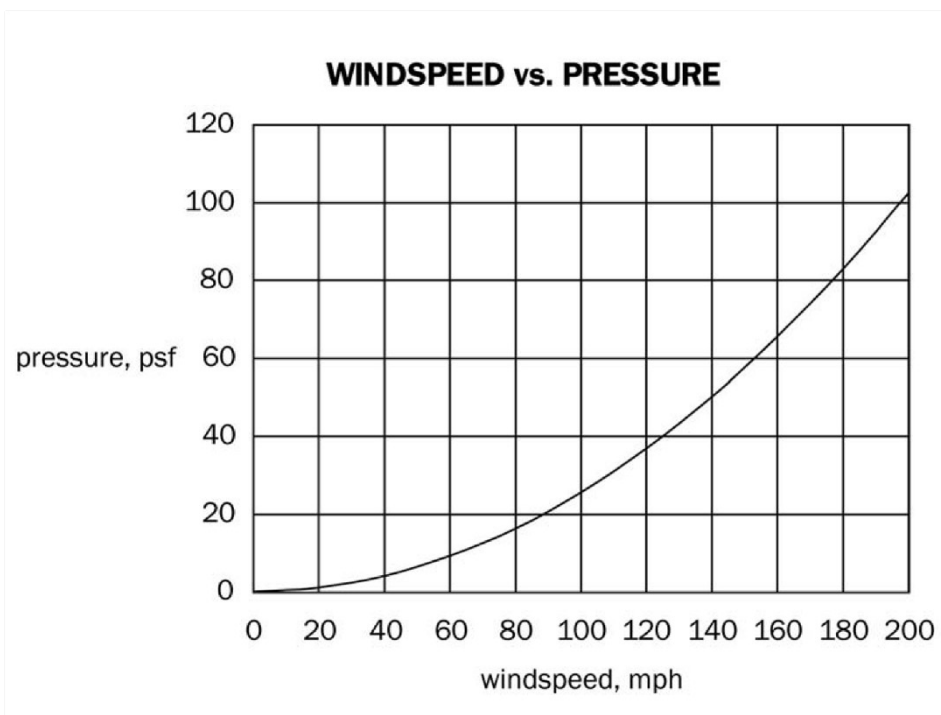

SUBJECT: SOUND TRANSMISSION OF PREMIER SIPS

Premier SIPS have been erected in numerous residential and commercial applications where the occupants have expressed great satisfaction with the reduced noise level within their structure due to the SIP construction. While these stories are anecdotal they indicate that structures built with Premier SIPS do provide a measure of sound attenuation.

Within the building industry, specific tests are used to determine the Sound Transmission Class (STC) of an assembly or component. ASTM E90 "Standard Test Method for Laboratory Measurement of Airborne Sound Transmission Loss of Building Partitions and Elements," subjects a wall assembly to random noises in a frequency range of 125 to 4000 Hz. The following are STC values for several Premier SIPS assemblies with a minimum 4 1/2" thickness, used in standard construction, which were determined through testing at an accredited independent laboratory. These assemblies are for typical **residential** applications:

Assembly A • STC: 22

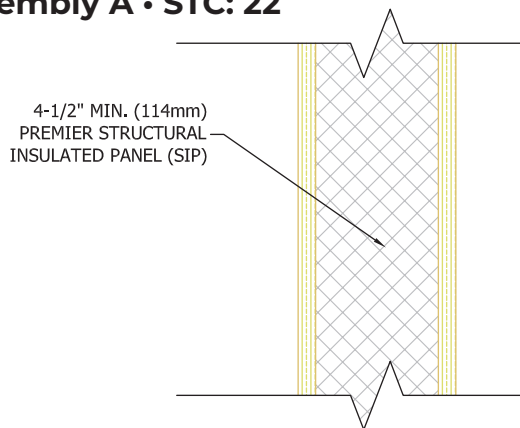

Assembly B • STC: 28

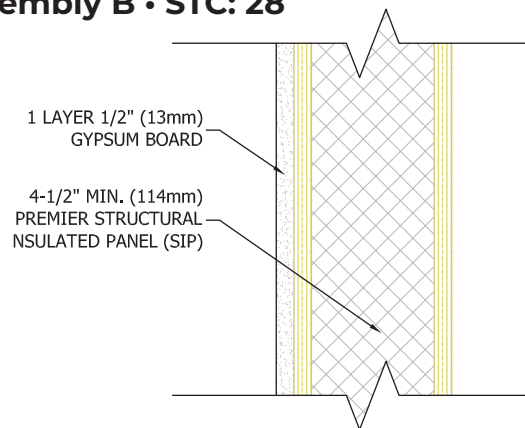

Assembly C • STC: 29

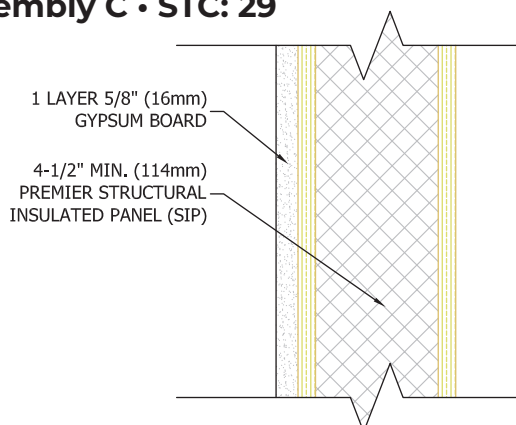

Assembly D • STC: 33

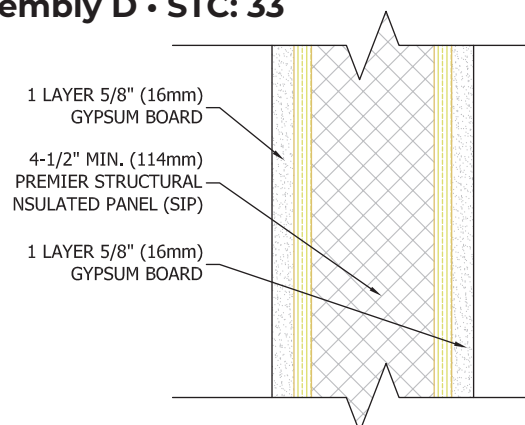

Assembly E • STC: 39

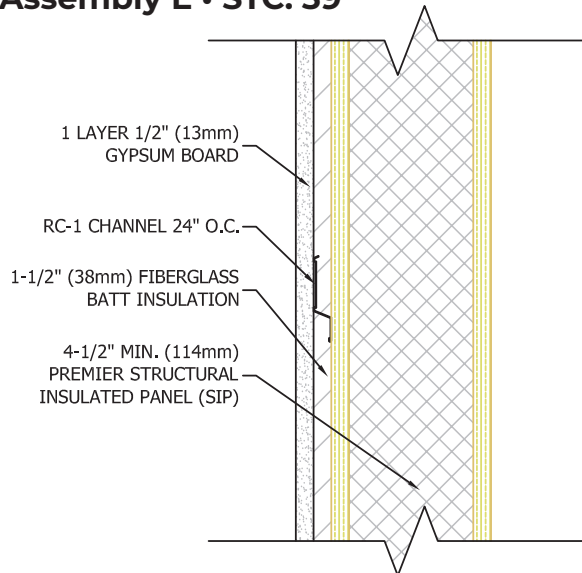

Assembly F • STC: 41*

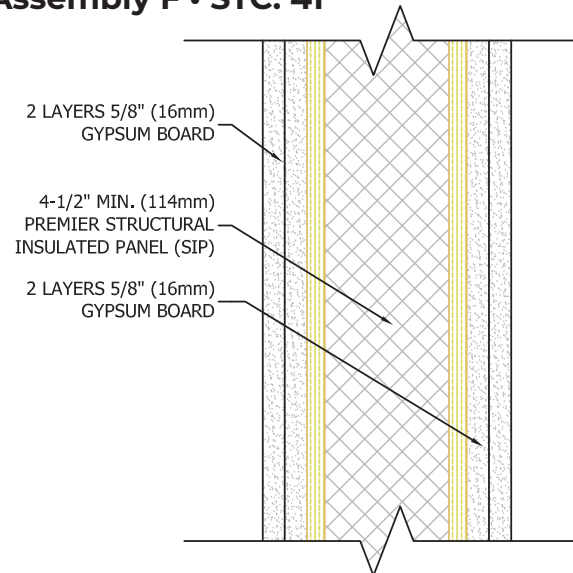

Assembly G • STC: 51*

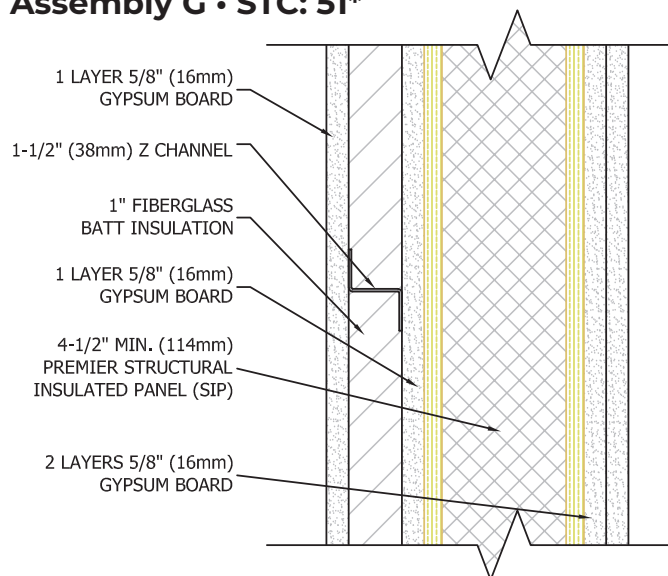

In all of the previous described assemblies, gypsum wallboard was attached using standard screws directly into the face of the SIP or metal channels. In multiple layer assemblies, the joints were offset a minimum of six inches from the joints of the previous layer.

Premier SIPS are also used in attached **multifamily** applications such as condominiums and town homes. Hence, Premier SIPS has also conducted ASTM E90 test on wall assemblies that produce higher sound attenuation while meeting fire and clearance requirements for these types of structures. These include the following four assemblies using Premier SIPS in conjunction with two types of PAC International Isolation clips to yield higher STC values. The assemblies are as follows:

Assembly H • STC: 48

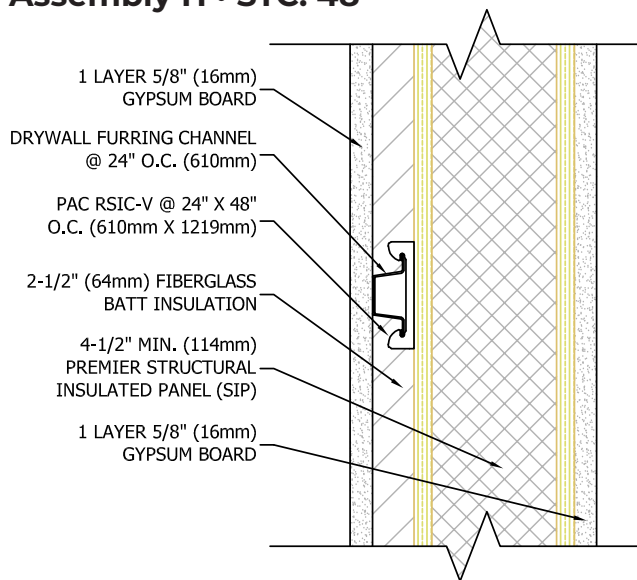

Assembly I • STC: 58*

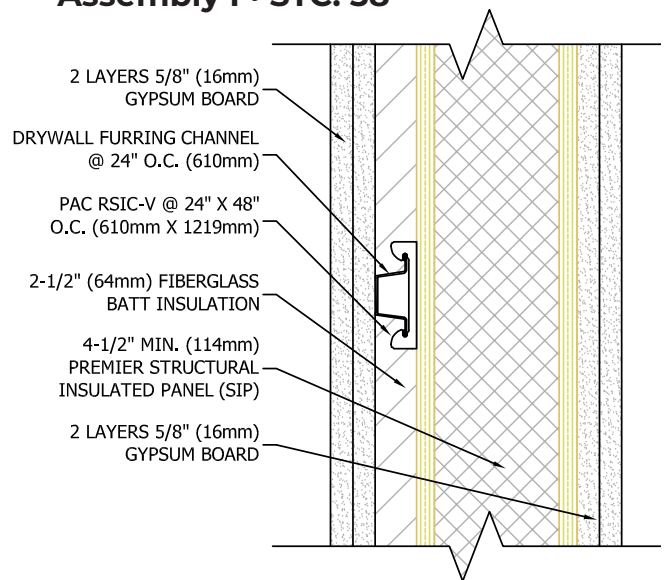

Assembly J • STC: 52

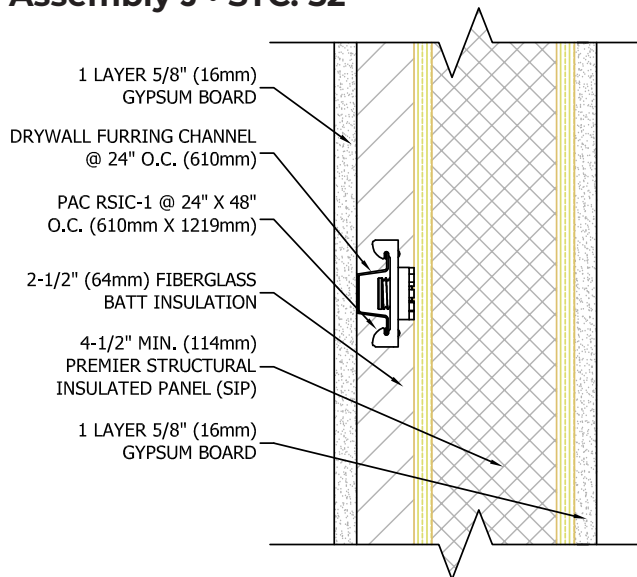

Assembly K • STC: 59*

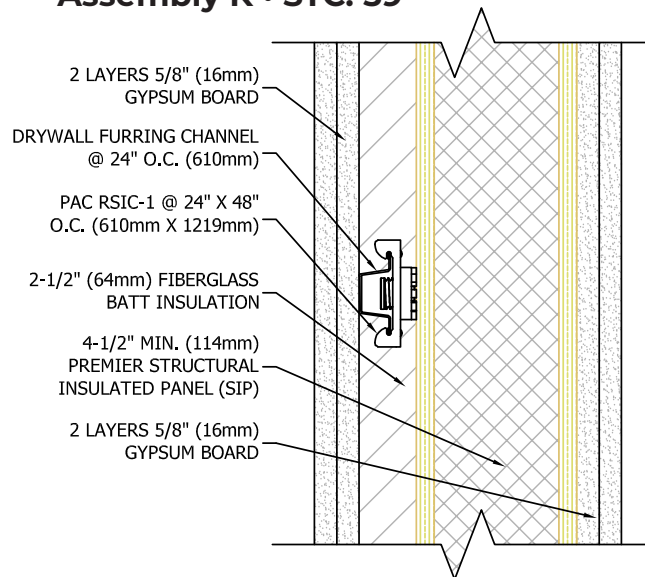

Assemblies 1 through 4 used standard drywall screws to fasten the gypsum to drywall furring channels attached to the RSIC-V or RSIC-1 Isolation clip assembly. In the multi-layered assemblies the gypsum wall board joints were staggered between layers.

The above results will be affected by the use of additional or different finish materials and are supplied as a reference value. It should also be noted that sound attenuation is dependent on installation practices. Penetrations, through the wall assembly for electrical, plumbing and other fenestrations (such as windows and doors), can affect the sound transmission performance of a wall. Design consideration should be given to any penetrations through a wall requiring a STC value.

For more construction details on PAC International isolation clips visit <https://pacinternationalllc.com/pac-products/rsic-1-product/>.

* These assemblies meet the requirements of UL U524 Bearing Wall Rating - 1 HR.

SUBJECT: SPLINES (MINIMUM WIDTH)

Premier SIPS use three types of splines for connecting its SIPS. The three types of splines are:

TYPE S SPLINE: Block spline, having a width of 3".

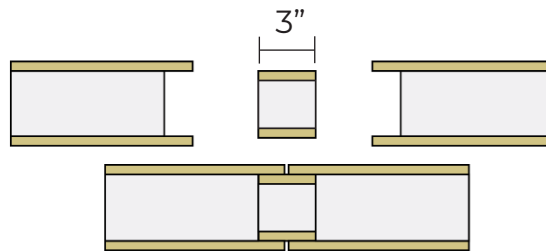

TYPE I SPLINE: I-Joist spline, having a width of 2 ½".

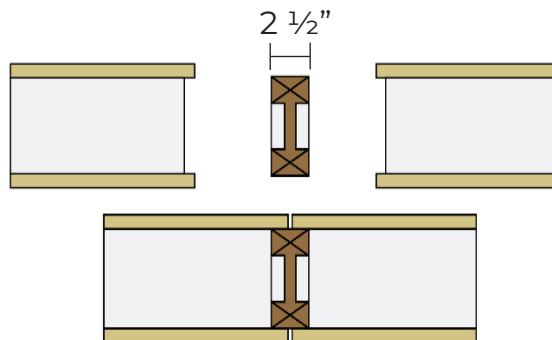

TYPE L SPLINE: Double 2x dimensional lumber spline, having a width of 3".

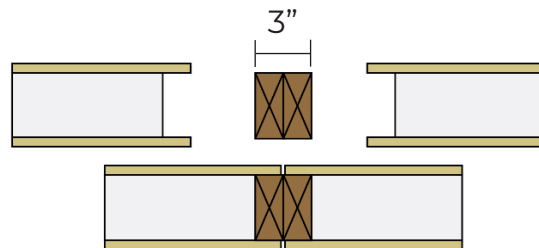

When following OSB manufacturers recommendation of 1/2" edge distance of spline to fastener, 3/8" edge distance of fastener to OSB on both sides of the 1/8" Sheathing Gap you end up with a minimum spline width of 1 7/8". However, that minimum of 1-7/8" spline width does not allow any room for the fasteners to deviate from the recommended edge nailing distances. Pneumatic nailing guns are used to install the fasteners and the accuracy with which an installer can hit the theoretical nailing line is impractical. Therefore, to ensure a proper nailing base for the fastening of joining Premier SIPS together, only splines that are 2.5" minimum width or greater are recommended by Premier SIPS. Further, Premier SIPS does not recommend the use of a single 2x, or any member that is less than 2 1/2" wide, as an acceptable spline member.

These splines and the corresponding minimum width for fastening have been recommended by OSB manufacturers for edge fastening distances and what is practical for actual site conditions.

That said, the minimum of 1-7/8" width for a spline does not allow any room for the fasteners to deviate from the recommended edge nailing distances. Pneumatic nailing guns are used to install the fasteners and the accuracy with which an installer can hit the theoretical nailing line is impractical. Therefore, to ensure a proper nailing base for the fastening of joining SIPS together, only splines that exceed a 2.5" minimum width is recommended by Premier Building Systems. Further, Premier does not recommend the use of a single 2x, or any member that is less than 2 1/2" wide, as an acceptable spline member.

SUBJECT: PREMIER SIPS WITH TYPE S (BLOCK) SPLINES

To offer our customers the optimum in energy efficiency, Premier SIPS utilize Block Splines (Premier Detail #PBS-200) as an interconnecting spline within our SIPs. Utilizing Block Splines virtually eliminates the thermal bridging that may occur with other types of spline options. Premier Building Systems commissioned an independent code recognized testing agency to conduct full-scale destructive transverse load testing to determine the design capacity loads of our Premier SIPS with Type S Splines for various span conditions. Premier Details can be accessed at www.premiersips.com.

The Premier SIPS Type S Load Chart summarizes the panel capacities obtained from full scale destructive testing of Premier SIPS with Type S Splines. The minimum bearing that is required to support the SIP end is 1-1/2". Loads shown on the Type S Spline, Premier SIPS Load Chart #6A (Page 2) for spans that exceed the limitations imposed on floors and roofs, are used for wall design.

TRANSVERSE LOAD

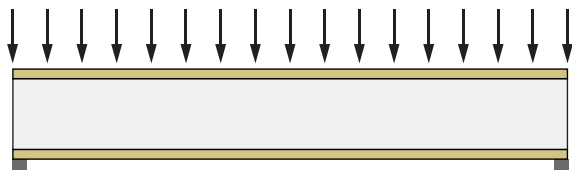

TYPE S SPLINE

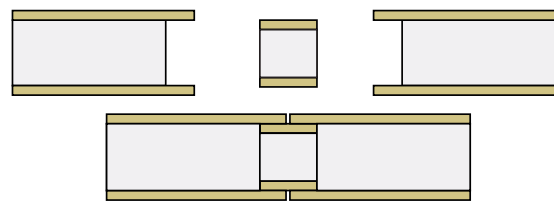

LOAD CHART #6A											
Roof/Floor Uniform Transverse Loads - PSF ¹⁻⁴											
Type S Spline											
SIP Thickness	Deflection Limit	SIP Span (ft.)									
		4' ⁴	8'	10'	12'	14'	16'	18'	20'	22'	24'
4-1/2"	L/360	100	32	23	NA	NA	NA	NA	NA	NA	NA
	L/240	143	48	35	NA	NA	NA	NA	NA	NA	NA
	L/180	143	63	47	NA	NA	NA	NA	NA	NA	NA
6-1/2"	L/360	105	51	38	29	23	NA	NA	NA	NA	NA
	L/240	162	76	57	44	35	NA	NA	NA	NA	NA
	L/180	191	80	61	50	42	NA	NA	NA	NA	NA
8-1/4"	L/360	120	67	51	40	32	26	22	NA	NA	NA
	L/240	179	94	71	57	48	40	33	NA	NA	NA
	L/180	179	94	71	57	48	41	36	NA	NA	NA
10-1/4"	L/360	131	86	66	52	43	35	29	25	21	NA
	L/240	168	94	75	63	54	47	41	36	32	NA
	L/180	168	94	75	63	54	47	41	36	33	NA
12-1/4"	L/360	132	94	75	63	53	44	37	32	27	23
	L/240	163	94	75	63	54	47	42	37	34	31
	L/180	163	94	75	63	54	47	42	37	34	31

¹ Table values assume a simply supported SIP with 1-1/2 inches (38.1 mm) of continuous bearing. Permanent loads, such as dead load, shall not exceed 0.50 times the tabulated load. Values do not include the dead weight of the SIP.

² Deflection limit shall be selected by building designer based on the serviceability requirements of the structure and the requirements of applicable building code. Values are based on loads of short duration only and do not consider the effects of creep.

³ Table values for 8-foot (2.44 m) spans apply to SIPs constructed with the OSB strength axis oriented either parallel or perpendicular to span direction. Table values for other spans are based on the OSB strength axis parallel to the span direction.

⁴ SIPs shall be a minimum of 8-foot (2.44 m) long spanning two 4-foot (1.22 m) spans.

Premier Details, Load Charts & Full Resource Manual can be accessed at:
www.premiersips.com.

SUBJECT: PREMIER SIPS WITH TYPE I (I-JOIST) SPLINES

To offer our customers the optimum in energy efficiency, Premier SIPS utilize APA Performance Rated I-Joists, reflected in Premier Detail #PBS-201 through 203, as an interconnecting spline within our SIPs. Utilizing the I-Joist spline minimizes the thermal bridging that may occur with other types of spline options. Premier commissioned an independent code recognized testing agency to conduct full-scale destructive transverse load testing to determine the design capacity loads of our Premier SIPS with a Type I Spline for various span conditions.

The Type I Spline, Premier SIPS Load Chart #6B (Page 2), summarizes the SIP capacities obtained from full scale destructive testing of Premier SIPS with Type I Splines. It should be noted that when an I-Joist is used as a spline member it is spaced at a maximum of 4' on center and must extend the full length of the SIP span as a single piece. Please refer to Premier Detail #PBS-203 contained in the Premier SIPS Resource Manual. Please note that the minimum bearing required to support the panel ends is 1-½". In the case of a single span roof SIP, spanning from the ridge to the eave, the 2x blocking at the top and bottom of the SIP will not be continuous because the I-Joist extends to both SIP bearing edges. Loads shown on the Type I Spline, Premier SIPS Load Chart #6B for spans that exceed the limitations imposed on floors and roofs, are used for wall design.

TRANSVERSE LOAD

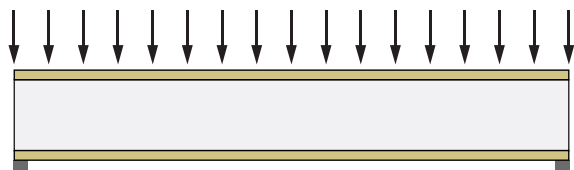

TYPE I SPLINE

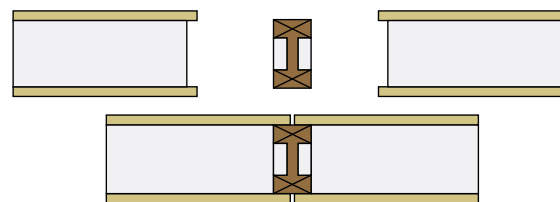

LOAD CHART #6B											
Roof/Floor Uniform Transverse Loads - PSF ¹⁻⁴											
Type I Spline											
SIP Thickness	Deflection Limit	SIP Span (feet)									
		4 ⁴	8	10	12	14	16	18	20	22	24
10-1/4"	L/360	197	164	124	72	67	61	48	34	29	24
	L/240	336	164	124	107	96	84	70	49	43	36
	L/180	336	164	124	107	96	84	76	65	56	47
12-1/4"	L/360	258	143	103	86	83	77	61	42	37	32
	L/240	318	143	103	93	85	77	68	59	54	46
	L/180	318	143	103	93	85	77	68	59	54	49

¹ Table values assume a simply supported SIP with 1-1/2 inches (38.1 mm) of continuous bearing. Permanent loads, such as dead load, shall not exceed 0.50 times the tabulated load. Splines consist of Premier I-beam, 2-1/4 inch (57.2 mm) wide flange (minimum) with a depth equal to the core thickness, spaced not to exceed 48 inches (1219.2 mm) on center.

² Deflection limit shall be selected by building designer based on the serviceability requirements of the structure and the requirements of applicable building code.

³ Table values for 8-foot (2.44 m) spans apply to SIPs constructed with the OSB strength axis oriented either parallel or perpendicular to span direction. Table values for other spans are based on the OSB strength axis parallel to the span direction.

⁴ SIP shall be a minimum of 8 foot (2.44 m) long spanning a minimum of two 4-foot (1.22 m) spans.

Premier Details, Load Charts & Full Resource Manual can be accessed at:
www.premiersips.com.

SUBJECT: PREMIER SIPS WITH TYPE L (LUMBER) SPLINES

Premier SIPS utilize Type L Splines when the structural design loads exceed the capacities of our standard Type S or Type I Splines. Premier SIPS Details #PBS-204 and #PBS-205, contained in the Premier SIPS Resource Manual, illustrate the Type L Spline connections. The double 2x's shown in the Premier SIP Type L Spline details must be both continuous pieces and extend for the full length of the SIP span.

Premier Building Systems commissioned an independent code recognized testing agency to conduct full-scale destructive transverse load testing to determine the design capacity loads of our Premier SIPS with Type L Splines for various span conditions.

The Premier SIPS Type L Load Chart summarizes the panel capacities obtained from full scale destructive testing of Premier SIPS with Type L Splines. When Type L Splines are utilized, the maximum spacing of the lumber spline is 4' on center. The minimum bearing that is required to support the panel end is 1-1/2". Loads shown on the Type L Spline, Premier SIPS #6 Load Chart (Page 2) for spans that exceed the limitations imposed on floors and roofs, are used for wall design.

TRANSVERSE LOAD

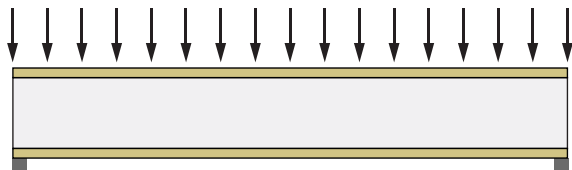

TYPE L SPLINE

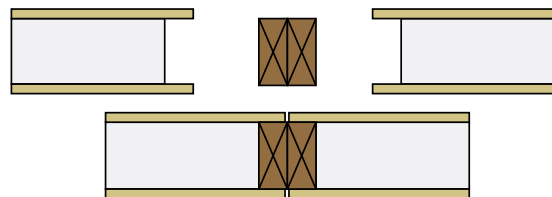

LOAD CHART #6C											
Roof/Floor Uniform Transverse Loads - PSF¹⁻⁴											
Type L Spline											
SIP Thickness	Deflection Limit	SIP Span (feet)									
		4 ⁴	8	10	12	14	16	18	20	22	24
4-1/2"	L/360	103	45	33	24	NA	NA	NA	NA	NA	NA
	L/240	225	68	47	34	NA	NA	NA	NA	NA	NA
	L/180	297	91	61	45	NA	NA	NA	NA	NA	NA
6-1/2"	L/360	307	129	57	42	34	25	20	NA	NA	NA
	L/240	307	182	87	61	49	37	30	NA	NA	NA
	L/180	307	182	112	80	65	49	39	NA	NA	NA
8-1/4"	L/360	253	171	82	66	54	41	32	23	NA	NA
	L/240	288	188	128	100	81	61	48	35	NA	NA
	L/180	288	188	133	117	105	80	63	45	NA	NA
10-1/4"	L/360	286	188	117	101	80	58	47	36	32	27
	L/240	326	188	147	134	120	90	71	52	47	41
	L/180	326	188	147	134	121	106	93	68	61	53
12-1/4"	L/360	327	188	167	141	116	91	75	58	47	36
	L/240	327	188	167	153	132	110	97	83	69	53
	L/180	327	188	167	153	132	110	97	83	83	70

¹ Table values assume a simply supported SIP with 1-1/2 inches (38.1 mm) of continuous bearing. Permanent loads, such as dead load, shall not exceed 0.50 times the tabulated load. Splines consist of No. 2 or better Hem-Fir, 1-1/2 inches (38.1 mm) wide with a depth equal to the core thickness, spaced to provide not less than two members for every 48 inches (1219.2 mm) of SIP width.

² Deflection limit shall be selected by building designer based on the serviceability requirements of the structure and the requirements of applicable building code.

³ Table values for 8-foot (2.44 m) spans apply to SIPs constructed with the OSB strength axis oriented either parallel or perpendicular to span direction. Table values for other spans are based on the OSB strength axis parallel to the span direction.

⁴ SIP shall be a minimum of 8 foot (2.44 m) long spanning two 4-foot (1.22 m) spans. No single span condition is allowed.

Premier Details, Load Charts & Full Resource Manual can be accessed at:
www.premiersips.com.

SUBJECT: PREMIER SIPS JOINT DETAILING

Premier SIPS are a high-performance building envelope system. To provide maximum comfort, energy savings and durability, Premier SIPS must be installed in compliance with Premier SIPS Details. A key component of a Premier SIPS building envelope is the proper use and application of Premier SIPS Sealant, Premier SIPS Tape and expanding foam sealants.

PREMIER SIPS SEALANT

Premier SIPS Sealant was specifically formulated for application in SIPs installation and is the only recommended sealant product for installation for all Premier SIPS Sealant applications including core, splines, wood plating and internal wood members.

Other adhesives or sealants have been shown to cause damage to the rigid insulation core or become brittle over time. Premier SIPS Sealant is EPS rigid insulation compatible and will retain its flexibility. In addition, some products cannot be applied under damp or cold conditions. Premier SIPS Sealant can be applied to damp surfaces, is water washout resistant and can be applied at low temperatures.

Of key importance, Premier SIPS Sealant prevents the passage of water vapor due to its low water vapor permeability.

Premier SIPS Sealant must always be installed in a continuous unbroken line pattern and applied in the recommended bead size (3/8" diameter) and location to ensure that contact is maintained with the core, splines, wood plating and internal wood members.

Please refer to the Premier SIPS Sealant Details and Installation video demonstrating the proper application of Premier SIPS Sealant, which can be viewed at www.premiersips.com/sealant.

Failure to apply the sealant in a continuous pattern or maintain contact with adjacent materials will provide paths for moisture vapor to pass through panel joints causing eventual moisture problems.

PREMIER SIPS TAPE:

Premier SIPS Tape was specifically formulated for application to Premier SIPS. Premier SIPS Tape is the only recommended tape product for installation on the surface of Premier SIPS. Other tapes are often manufactured with asphalt adhesives which are not suitable for use in interior environments.

Please refer to the Premier SIPS Tape Details and Installation Video demonstrating the proper application of Premier SIPS Tape, which can be viewed at www.premiersips.com/tape.

EXPANDING FOAM SEALANTS:

Premier Building Systems does not recommend the use of expanding foam sealants as a vapor retarder in the critical area of joint detailing between the SIP core, splines, wood plating and internal wood members. Expanding foams become brittle as it ages and can crack in tight margin areas such as SIP joints where expansion and contraction can occur.

Additionally, the field installation of expanding foam sealants can be difficult under typical construction site environments such as cold or damp weather conditions. In addition, the long-term volume stability and flexibility of foam sealants cannot be guaranteed. Field inspection of past foam sealant panel applications has shown that problems with expanding foam sealant performance can occur.

However, the use of low expanding foam sealants in the application of filling voids around electrical boxes and window and door openings is recommended. These applications take place in the controlled environment on the inside of a standing SIPs structure

SUBJECT: PREMIER SIPS HEADER OPTIONS

When erecting structures that utilize Premier SIPS for the wall assemblies, several header design options are available when a load needs to be carried over a window, door, or other opening. Premier SIPS provide several options that include SIPs, where the SIP itself is the header, or an Insulated Header that is a factory composite of engineered lumber, plus rigid insulation.

Premier Headers and Insulated Headers are best suited for Premier SIPS structures since both options provide insulation and reduce thermal bridging in the header area.

When a header is required, its load carrying capacity must be established and determined by the designer, to ensure it is acceptable for its intended application.

In cases where a concentrated load is placed over an opening, or the design loads exceed the capacity of a Premier SIPS Header, a Premier SIPS Insulated Header should be used. If neither of the two Premier SIPS header options work for the opening condition, other engineered header assemblies will need to be considered by the designer.

Please refer to Premier SIPS Load Charts #5A, #5B & #5C to obtain the necessary design information required. Also, refer to Premier Details #PBS-407 through #PBS-411.

Premier Details, Load Charts & Full Resource Manual can be accessed at: www.premiersips.com.

SUBJECT: SIPS SCREWS

Premier SIPS Wood and Metal screws are available from Premier Building Systems for the attachment of Premier SIPS to wood or metal substrates. These screws were developed to provide an engineered fastener that meets the requirements of Premier SIPS building code recognized assemblies.

Please find attached engineering properties (pages 2-4) for the Premier SIPS Wood Screws, Light-Duty Metal Screws and Heavy Duty-Metal Screws. The properties include withdrawal, shear, pull through and tensile strength.

The values provided for the Premier SIPS Screws are maximum values. Appropriate safety factors should be applied for the design as determined by the project architect and/or engineer.

WOOD SCREWS:

Premier SIPS Wood Screws are used to attach SIPs to wood structural members and substrates.

LIGHT-DUTY METAL SCREWS:

Premier SIPS Light-Duty Fasteners are used to attach SIPs to light gauge steel members up to 16-gauge thickness metal.

HEAVY-DUTY METAL SCREWS:

Premier SIPS Heavy-Duty Metal Screws are used to attach SIPs to metal structural members and substrates. Premier SIPS Heavy-Duty Metal Screws can self-drill into 3/16" steel without pilot hole predrilling. Installation is direct and fast; no wood nailers are required.

The Heavy-Duty Metal Screw should be driven with a low rpm (<1500 rpm) high torque drill. Firm, but not excessive, pressure should be applied. This allows the drill point to engage the surface of the metal to cut and clear away metal kerf, letting the threads of the screw pull through the metal substrate. Excessive pressure and/or rpm will dull the drill point and render the screw ineffective.

TECHNICAL BULLETIN

NO. D-15

PREMIER WOOD SCREW PROPERTIES

The Premier Wood Metal Screw property values provided are average ultimate values. As determined by the project architect/engineer, appropriate safety factors must be used in design.

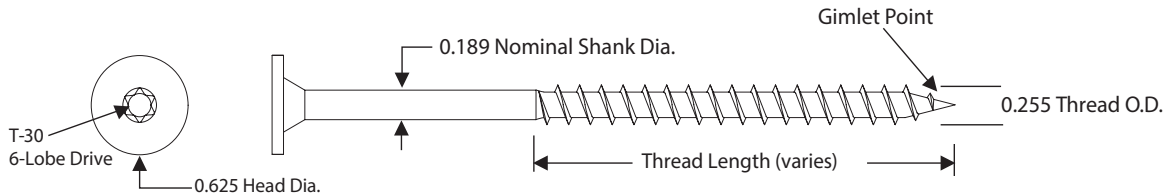

WOOD SCREW PROPERTIES			
Tensile (lbs) AISI S904	Shear (lbs) AISI S904	Bending Yield Strength - Fyb (psi) ASTM F1575	Corrosive Resistance ASTM D6294, ETAG 006
3555	2580	185,000	<15% Red Rust after 30 cycles

WITHDRAWAL: LUMBER & ENGINEERED WOOD - LBS./IN. ^{1,2}							
SPF/HF (0.42)		DF/SP (0.50)		LVL (0.50)		LSL (0.50)	OSB (7/16")
Face Grain	Edge Grain	Face Grain	Edge Grain	Face Grain	Edge Grain	Face Grain	Face
799	615	899	702	556	495	711	265

¹ Load values include fastener tip.

² 1" fastener embedment into face / edge grain.

WITHDRAWAL: CONCRETE & CMU - LBS. ¹		
2500 psi Concrete	5000 psi Concrete	CMU ²
682	869	713

¹ Fastener penetrates 1" into concrete or CMU clock, including the tip.

² Concrete Masonry unit (CMU) conforming to ASTM C90.

HEAD PULL-THRU - LBS.	
7/16" OSB	SIP
490	630

LATERAL LOAD RESISTANCE - LBS.		
Main Member	Side Member	Load
SPF ^{1,2}	4-1/2" to 12-1/4" SIP	943

¹ 1-3/4" fastener embedment into edge grain, including tip.

² 1" fastener embedment into face grain, including tip.

TECHNICAL BULLETIN

NO. D-15

PREMIER LIGHT DUTY METAL SCREW PROPERTIES

The Premier Light Duty Metal Screw property values provided are average ultimate values. As determined by the project architect/engineer, appropriate safety factors must be used in design.

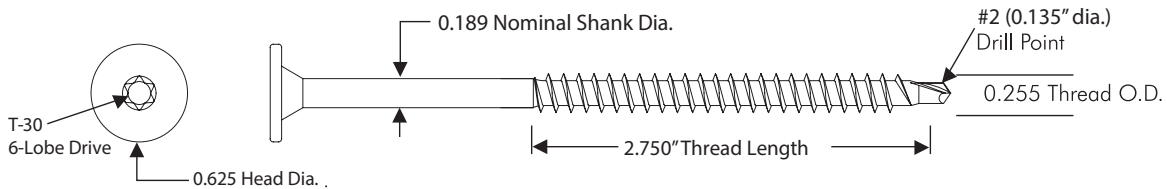

LIGHT DUTY METAL SCREW PROPERTIES			
Tensile (lbs) AISI S904	Shear (lbs) AISI S904	Bending Yield Strength - Fyb (psi) ASTM F1575	Corrosive Resistance ASTM D6294, ETAG 006
3390	2490	185,000	<15% Red Rust after 30 cycles

WITHDRAWAL: CORRUGATED STEEL DECK - LBS.						
24 ga. (36 ksi)	22 ga. (36 ksi)	22 ga. (85 ksi)	20 ga. (36 ksi)	18 ga. (36 ksi)	16 ga. (36 ksi)	16 ga. (100 ksi)
250	381	435	449	694	896	1186

* Minimum 3/4" penetration of fastener through deck from underside of deck.

WITHDRAWAL: LUMBER & ENGINEERED WOOD - LBS./IN. ¹							
SPF/HF (0.42)		DF/SP (0.50)		LVL (0.50)		LSL (0.50)	OSB (7/16")
Face Grain	Edge Grain	Face Grain	Edge Grain	Face Grain	Edge Grain	Face Grain	Face
662	497	732	720	540	469	646	284

¹ Load values include fastener tip.

HEAD PULL-THRU - LBS	
7/16" OSB	SIP
490	630

TECHNICAL BULLETIN

NO. D-15

PREMIER HEAVY DUTY METAL SCREW PROPERTIES

The Premier Heavy Duty Metal Screw property values provided are average ultimate values. As determined by the project architect/engineer, appropriate safety factors must be used in design.

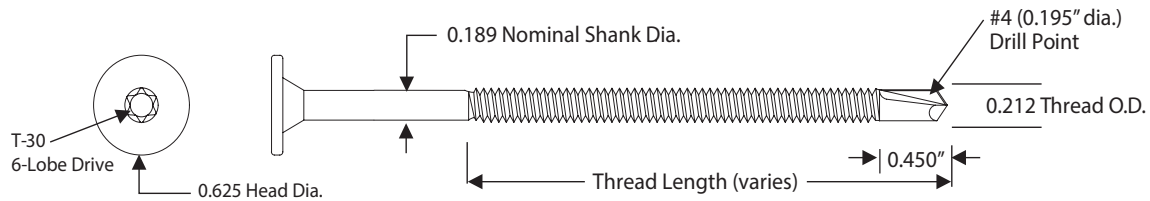

HEAVY DUTY METAL SCREW PROPERTIES			
Tensile (lbs) AISI S904	Shear (lbs) AISI S904	Bending Yield Strength - Fyb (psi) ASTM F1575	Corrosive Resistance ASTM D6294, ETAG 006
3855	2625	185,000	<15% Red Rust after 30 cycles

WITHDRAWAL: CORRUGATED STEEL DECK - LBS. ¹					
16 ga. (36 ksi)	16 ga. (100 ksi)	12 ga. (50 ksi)	1/8" (36 ksi)	3/16" (60 ksi)	1/4" (60 ksi)
491	794	1255	1454	3098	3814

¹ Minimum (3) threads of penetration of fastener through deck as measured from underside of steel.

HEAD PULL-THRU - LBS.	
7/16" OSB	SIP
490	630

LATERAL LOAD RESISTANCE - LBS.		
Main Member	Side Member	Load
1/8" Structural Steel ¹	4-1/2" to 12-1/4" SIP	929

¹ Minimum (3) threads of penetration of fastener through steel as measured from underside of steel.

SUBJECT: SCREW WITHDRAWAL CAPACITIES OF OSB

To finish a project that utilizes Premier SIPS for the walls and roof of a structure, many types of materials need to be fastened to SIPs. These materials can include siding, roofing materials, other structural elements, cabinets and a host of others.

In many of these applications screws are the preferred method of fastening. To help quantify the performance of screw withdrawal from OSB, a major manufacturer of OSB generated test data on various screw types and sizes withdrawn from various thicknesses of OSB. Prior to the withdrawal testing, the OSB was exposed to three different environmental conditions – dry, wet, wet/dry. Fifteen repetitions of both direct and lateral withdrawal from the environmentally conditioned OSB were conducted on the screw types and sizes shown in the charts below. The following tables summarize the lowest ultimate average value achieved for each screw type and size when withdrawn from three different thicknesses of environmentally conditioned OSB.

Average Direct Withdrawal (Pullout) - lbs.

Screw Size	7/16" OSB	5/8" OSB	3/4" OSB
#6 Deck Screw	177	272	324
#8 Deck Screw	182	309	359
#10 Deck Screw	198	355	363
#12 Roofing Screw	190	312	360
#14 Roofing Screw	177	340	393

These values are ultimate values. Appropriate safety factors should be applied to obtain design values.

Average Lateral Withdrawal (Shear) - lbs.

Screw Size	7/16" OSB	5/8" OSB	3/4" OSB
#6 Deck Screw	198	273	295
#8 Deck Screw	118	197	224
#10 Deck Screw	143	260	301
#12 Roofing Screw	436	581	561
#14 Roofing Screw	466	630	797

These values are ultimate values. Appropriate safety factors should be applied to obtain design values.

SUBJECT: NAIL WITHDRAWAL CAPACITIES OF OSB

With the use of Premier SIPS, the attachment of finishing materials such as roof shingles, siding, drywall, etc., is required. The application of these materials is typically accomplished with conventional nail products. An independent code recognized testing agency conducted withdrawal tests following ASTM D1037 procedures to provide data on the direct withdrawal resistance of nail fasteners when driven into the 7/16" OSB face of SIP. The following is a summary of the average ultimate values achieved for various nail fasteners.

AVERAGE DIRECT WITHDRAWAL (PULLOUT) – LBS.

Nail Size & Description	Avg. Ultimate Pullout	Nominal Shank Diameter
4d ring shank-drywall nail	133	0.109"
6d smooth galvanized	59	0.120"
Roofing Nail-smooth galvanized	51	0.110"
8d smooth coated sinker	150	0.131"
8d smooth galvanized spiral shank	112	0.120"
8d galvanized ring shank	77	0.113"
8d smooth galvanized	65	0.134"
8d bright box	107	0.113"
10d galvanized ring shank	164	0.148"
16d smooth galvanized	63	0.165"
16d bright box	90	0.135"

These values are ultimate values. Appropriate safety factors should be applied to obtain design values.

This data has been compiled to provide manufacturers, designers and engineers with values for the assessment of fastener requirements.

SUBJECT: WINDOW INSTALLATION DETAILS

Premier SIPS are a high-performance building material. To provide maximum comfort, energy savings and durability for the building envelope, the selection of high-performance windows are required to complement the performance of Premier SIPS. Regardless of window type selected, proper installation of window flashing materials is required. Window flashing consists of the following basic steps for installation of integral flanged windows in new construction:

1. Installation of weather-resistive barrier on wall.
2. Proper cutting of weather-resistive barrier to conform to window openings. The weather resistive barrier at the head opening is held up temporarily.
3. Installation of sill flashing.
4. Installation of caulk to jambs and head of window opening (not sill) or to window directly.
5. Fasten window into opening according to manufacturer's instructions.
6. Install weather resistive barrier overhead flashing.

These basic steps above are a general outline of the process that must be completed to properly flash a window opening.

Many commercial products are available which are suitable for use as flashing products with Premier SIPS.

Regardless of the product selected for flashing windows installed onto Premier SIPS, the flashing manufacturer's and window manufacturer's installation guidelines must be followed completely.

SUBJECT: WIRING PREMIER SIPS

Premier SIPS can be manufactured with 1-½” diameter wiring chases in the panel cores for quick access by the electrical contractor. The chases are typically located at 45” and 16” off the finished floor, as well as vertically 4’ on center. These locations, as well as any custom chases, should be verified during the shop drawing phase.

Type NM-B cable, as Classified by Underwriters Laboratories, passes UL-719 that mandates a maximum conductor temperature of 90 degrees C (194 degrees F). The conductor temperatures under normal loads will not exceed 60 degrees C, due to the restrictions on amperage loading and breaker sensitivity.

The wiring used for most residential and light commercial structures, commonly referred to as “Romex”, is widely available with the NM-B designation and is UL Classified and acceptable for use with Premier SIPS.

It is strongly recommended that you review the electrical chase design for your project with your electrical contractor representative early in the design process and provide this information to the Premier SIPS Project Services Team to ensure a proper chase layout. It is recommended that your electrician work around obstacles such as doors, windows, and other openings.

Please refer to the Premier SIPS electrical details (#PBS-106, 107, and 108) and view the Premier SIPS Electrical Installation Video demonstrating the proper wiring of Premier SIPS available at www.premiersips.com/electrical.

SUBJECT: RECESSED LIGHTING IN PREMIER SIPS

The primary considerations for the installation of recessed lighting in Premier SIPS include potential excessive cutting of the structural facing and excessive heat. (Refer to Premier SIPS ICC ESR-4524, Section 4.2.9.2, Holes in Panels, paragraph 2 and to Premier SIPS Technical Bulletin I-1.)

The SIPs facing is a key structural component. Therefore, excessive cutting of the SIP OSB facers, along with the foam core may lead to a reduction in the structural capacity of the SIPs. Heat buildup with recessed lights is the result of being installed in a fully insulated cavity. Although some recessed lights are designated for insulated cavities, these lights are not designed for the superior insulating performance of the rigid insulation solid core within the SIP.

Premier recommends the installation of surface mount, or track lighting when SIPs serve as the ceiling. If a flush appearance is desired, a cavity or soffit can be created by the installation of framing material attached to the surface of the SIPs before the installation of gypsum board. This creates a cavity or soffit in which lighting can be installed without cutting the face of the SIP. The use of recessed lighting is not recommended for application within a SIP.

However, if recessed lights are desired to be installed in a Premier SIPS, the engineer of record for the project should be consulted regarding the number and location of planned cuts in the SIPs. The engineer must review these cuts to ensure the structural integrity of the SIPs is not compromised. In addition, since the core of the SIP is rigid insulation, the opening into the SIPs will expose the rigid insulation core. A minimum of 2X dimensional lumber blocking or 1/2" gypsum board must be installed over the exposed rigid insulation prior to the installation of the light fixture.

SUBJECT: FIRE-RESISTANCE-RATED ASSEMBLIES

WALL: TWENTY MINUTE RATING

A Premier SIPS wall section faced with 1/2" gypsum board, with an electrical outlet and wiring in place was tested. Foam sealant was placed around the outlet opening following Premier Detail #PBS-108. The results from ASTM E119 testing showed that Premier SIPS, having electrical outlets, wiring and factory precut chases detailed per Premier Detail #PBS-108 and faced with 1/2" gypsum board, complies as a twenty-minute fire rating per the criteria of ASTM E119 (UL 263). Reference: ULR12389 89NK14D67.

A Premier SIPS wall section faced with a single layer of gypsum board was tested. The results from ASTM E119 testing showed that Premier SIPS when faced with 5/8" gypsum board exceeds the requirement of a twenty-minute fire rating per the criteria of ASTM E119 (UL263). Reference: SWRI Pro. No. 01-8305-52b.

WALL: 1-HOUR RATING

Premier SIPS with two layers of 5/8" Type X gypsum board applied to the face, having an outlet and wiring in place and an intumescent caulk placed around the electrical outlet opening complies as an hourly wall assembly per the criteria of ASTM E119 (UL 263). Please refer to ICC ESR-4524, Premier SIPS Wall Assembly, Section 4.2.1.1 Fire-resistance-rated Assemblies - View code reports at www.premiersips.com/code-reports.

WALL: 1-HOUR RATING

Premier SIPS with one layer of 5/8" Type C gypsum board applied to the face and connected using (2) 2X dimensional lumber splines, 4' on center, and top plates complies as an hourly wall assembly per the criteria of ASTM E119 (UL 263). Please refer to ICC ESR-4524, Section 4.2.1.1 Fire-resistance-rated Assemblies.

ROOF/CEILING: 1-HOUR RATING

Premier SIPS with two layers of 5/8" Type X gypsum board applied to the face complies as an hourly roof/ceiling assembly per the criteria of ASTM E119 (UL 263). Please refer to ICC ESR-4524, Roof Assembly, Section 4.2.1.1 Fire-resistance-rated Assemblies.

All current code reports are available at www.premiersips.com.

SUBJECT: COMBUSTION TOXICITY OF PREMIER SIPS

Premier SIPS have undergone numerous fire tests for fire and life safety and code recognition of our SIPs and their components, including ASTM E84 “Test Method for Surface Burning Characteristics of Building Materials”, ASTM E119 “Standard Fire Tests of Building Construction and Materials”, UL 1715 “Safety Fire Test of Interior Finish Material”. As a result of this successful fire testing, Premier SIPs are recognized by the International Code Council’s Evaluation Services to comply with the fire and life safety requirements of both the International Building Code and the International Residential Code. Please refer to the Premier SIPS ICC ESR-4524 for information regarding code recognized Fire Rated Assemblies.

It is accepted that when a material is burned, combustion gases are given off. In building fires, the materials that compose the interior of the structure, i.e., carpet, furniture, etc., are the primary threat when considering toxic combustion gases. In the case of Premier SIPS, the primary gases given off are carbon monoxide, carbon dioxide and water vapor. These gases are found in many fires containing organic materials. Premier SIPS, when burned, give off by-products that are like those found when wood is burned. These gases are around us all the time. However, when they are in high concentrations as the result of a fire, they can cause asphyxiation.

Premier Building Systems believes strongly in fire and life safety first and foremost and thus, always recommends the use of non-combustible fire protection thermal barriers as required by the building code. An example would be gypsum board applied to all interior surfaces of the SIPs structure, thereby providing excellent fire protection to the structure and its inhabitants.

SUBJECT: EXPOSURE TO EXCESSIVE TEMPERATURES

Premier SIPS are a structural engineered component, providing both insulation and structure. Premier SIPS are manufactured with Exposure I rated Oriented Strand Board (OSB) facings and an Expanded Polystyrene (EPS) rigid insulation core. The rigid insulation core provides the structural connection between the OSB facings and must be protected for the life of the structure from exposure to excessive heat that may damage the rigid insulation.

TEMPERATURE:

The maximum recommended use temperature for the rigid insulation core is 165°F (75°C). The temperature that the Premier SIPS are exposed to is a function of exterior temperature, building orientation relative to the sun, building elevation and the type of roof covering material(s) used. In most locations across the United States and with the use of standard roof covering material(s), the Premier SIPS core will not be exposed to temperatures over 165°F.

Peak temperatures typically occur under the following conditions: south facing, low or medium slope, and dark colored roofs. In these situations, roof surface temperatures have been documented to reach temperatures of 200°F or higher on sunny days in the southern U.S. Roof designs which include wall/roof intersections oriented toward the sun may also result in high roof temperatures. If the roof temperature is anticipated to exceed 175°F, a ventilated roofing system is recommended over Premier SIPS.

Metal roof systems have inherent properties that transfer and build heat that potentially could cause a Premier SIPS roof deck to exceed a safe use temperature. When installing metal roof systems over Premier SIPS, additional design considerations may be necessary to protect the roofing underlayment and the Premier SIPS from excessive temperatures. These design strategies may include the use of a ventilated air space above the Premier SIPS to minimize temperature exposure.

Another source of excessive temperature exposure to Premier SIPS roof and wall structures can be from reflective surfaces, such as windows having reflective coatings and reflective water features. In these situations, the rays of the sun are reflected off these features, resulting in concentrated heat energy being projected onto wall and roof surfaces. Again, if these temperatures exceed 165°F, the rigid insulation core damage may occur.

To prevent potential damage from reflective features, light colored reflective cladding materials should be selected for walls and roofs on areas of the SIP structure where concentrated reflective light will hit. An additional method to protect SIP walls from concentrated reflective light is to install a ventilated rain-screen cladding system over the SIPs. (See Premier Technical Bulletin #R-7 for information about “Ventilating Mats” that provide water management, ventilation, and heat reduction to SIP exterior surfaces.)

Consult your local Premier SIPS representative for specific recommendations for your geographical location and building design. In addition, temporary roof, wall, or floor coverings must be breathable to ensure that a Premier SIPS structure is not subjected to excessive temperatures. For example, the use of clear poly (not breathable) as a temporary roof covering may lead to a greenhouse effect that could damage the SIP structure.

SUBJECT: EXPOSURE TO SOLVENTS

Content Premier SIPS are commonly used as a structural component because they provide both insulation and structure in a single component. Premier SIPS are manufactured with Exposure I rated structural Oriented Strand Board (OSB) facings and a rigid insulation core (Expanded Polystyrene - EPS). The rigid insulation core provides the structural connection between the OSB facings and must be protected for the life of the structure from exposure to solvents that may damage the rigid insulation core.

Solvents: The rigid insulation core may be attacked and damaged by some solvents and/or their vapors. The installation of roof coverings, wall covering, or other materials attached to Premier SIPS must be done with water based and /or low VOC materials, as materials containing solvents could lead to damage of the Premier SIPS rigid insulation core.

In addition, temporary roof, wall, or floor coverings must be breathable to ensure that any damaging solvent vapors present in the construction of the Premier SIPS structure are able to breathe quickly through the temporary covering materials. For example, the use of clear polyethylene (not breathable) applied over asphalt paper may lead to the trapping of solvents that could damage the SIP structure.

Note: The use of water based and/or low VOC adhesives, sealants, coatings, cleaning solutions, etc. help to meet the ever growing need to eliminate solvent based VOC emitting materials used in construction. The selection and use of water based and/or low VOC materials also furthers building practices that improve air quality performance in buildings. Premier SIPS supports these important initiatives by obtaining Clean Air Certification for its SIP assembly and construction sealant.

SUBJECT: RECOMMENDED EXPOSURE TO SIPS OSB FACERS

The Structural Grade Performance Rated OSB material used in the manufacture of Premier SIPS is recognized as a qualified Structural Insulated Panel facing material according to criteria outlined in the following:

- IRC Section R610 (2015-2021) [Section R613 (2012)]
- ANSI/APA PRS 610, Standard for Performance-Rated Structural Insulated Panels (APA 2-18)

The OSB used as the facing component in Premier SIPS is also approved by the ICC in Premier's Code Report #ESR-4524.

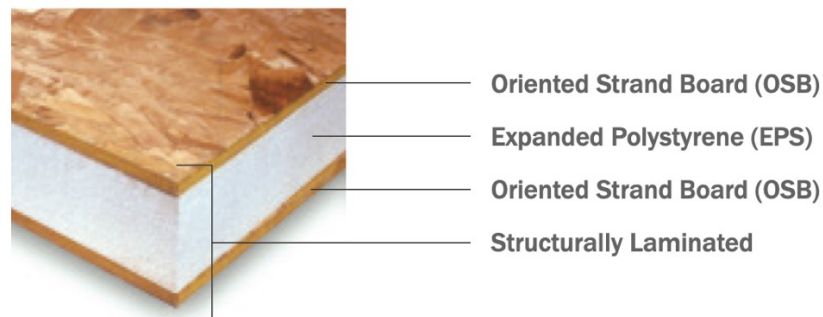

The APA (Engineered Wood Association) has also tested and made recommendations for appropriate weather exposure during construction (Doc X501). **Review these recommendations on the following pages.**

You can also find all current APA testing, recommendations and additional related documents at: www.apawood.org.



FAQs

Questions About Wood Structural Panel Exposure to Excessive Moisture

This document provides guidance about the serviceability of wood structural panels (plywood and oriented strand board [OSB]) after exposure to high levels of moisture, such as significant weather events during the construction process or when construction sites are delayed but moisture management steps aren't taken. Wood structural panels can also be exposed to high levels of moisture after the construction process is complete due to flooding. *Note: This document is not intended to address potential health and indoor air quality concerns that may arise from flooding.*

APA Trademark Identification and Water-Resistant Adhesives

The APA panel trademark will typically be in black ink, printed in one or more places on one side of the panel. Since 1972, all APA-trademarked plywood and OSB has been manufactured using water-resistant adhesives. The presence of the words "Exposure 1" or "Exterior" in the APA trademark assures that panels are manufactured with water-resistant adhesive.

Some plywood panels that were manufactured prior to 1972 may contain adhesives which are not fully water-resistant. These panels can be identified by the term "Interior" in the trademark. Older panels may have APA trademarks or trademarks that include "DFPA," which corresponds to APA's original name, the Douglas Fir Plywood Association.

Wood Construction and Water

Wood construction is durable and will normally be structurally sound after severe exposure to moisture. Structural plywood and OSB used in floors, walls and roofs are made with water-resistant adhesives and retain their strength following wetting events. Although the surface of the panels may be rougher from water exposure, they generally remain structurally sound. However, panels saturated with water will feel less stiff than those in a dry condition. Once the panels re-dry, strength typically returns, and only minor repairs may be necessary. Until the panels are dry, they should not be subjected to heavy loading, such as repeated heavy foot traffic or loaded drywall carts.

FAQs: Questions About Wood Structural Panel Exposure to Excessive Moisture

What Will Plywood or OSB Panels Look Like After A Re-Dry?

They will not look as good as when they were new, but they should be serviceable. Because they are a wood (hygroscopic) product, both plywood and OSB can be expected to expand after wetting. This is commonly observed as swelling at panel edges and increased surface unevenness. Localized swelling or blistering over knotholes and core gaps may be evident, but this condition does not compromise the structural integrity of the panel. Some lifting or flaking of surface strands on OSB panels may also occur. Structural tests show that such surface degradation does not result in a loss of panel structural capacity after the panel dries to in-service moisture conditions.

What About Buckling?

Buckling of wood structural panel sheathing occasionally results when increased moisture conditions cause the wood sheathing to expand. Such buckling may occur between supports or between nails along supports. Although structural properties are unaffected, the resulting waviness may affect the building's appearance and lead to complaints. Builders can significantly reduce the potential for buckling by ensuring a minimal increase in moisture content of the wood panels during construction and providing for its natural expansion by properly spacing and fastening the panels.

Once buckling has occurred, there are two primary remedies that can help minimize buckled panel areas:

1. First, run a circular saw (set to the panel thickness, and no deeper) along the panel joints. This is called "kerfing," and will help relieve the internal panel stresses that cause buckling. If the tongue-and-groove edges of floor panels are cut, they must be blocked from underneath, or a layer of APA plywood underlayment must be installed over the subfloor, with the underlayment joints offset from the subfloor joints. Keep in mind that kerfing and drying may not completely remedy buckling. See *APA Data File: Selection, Installation and Preparation of Plywood Underlayment*, Form L335.
2. The second step involves installing blocking under the buckled portions to flatten the panels.
 - a. Identify the buckled area and measure the distance between the structural members supporting the buckled panel area.
 - b. Cut a piece of lumber that is the same dimension as the supporting framing (e.g., for a 2x10 joist, cut the support blocking from another 2x10).
 - c. Depending on the direction of the buckling, the buckled panel will either need to be pushed up by the support block (which would then be nailed into the adjacent framing) or be pressed down tight to the previously installed blocking. In both cases, additional fasteners are used to connect the panel and the blocking.

FAQs: Questions About Wood Structural Panel Exposure to Excessive Moisture

What About a Rough Floor Surface?

Panels exposed to extended moisture may exhibit a rough surface. Some finish floor coverings, such as carpet and pad, may mask any unevenness and not require remediation. If the finish is sensitive to the smoothness of the panel, it may be possible to professionally sand the panel face and edges with a commercial sander. Installing a layer of APA plywood underlayment over the subfloor usually will correct the problem. Offset all panel edges and nail to the existing subfloor with ring-shank nails that pass through the subfloor by about 1/4 inch. See *APA Data File: Selection, Installation and Preparation of Plywood Underlayment*, Form L335.

How to Prevent Floor Squeaks?

Floor squeaks result when components within a floor system move as stepped on. Floor noise most commonly involves a subfloor that is not held tight to floor supports and is able to move against something metal, like a nail. In addition to misinstalled panels, subfloor movement can also result when panels are fastened into higher moisture content lumber framing, which will eventually dry to a lower moisture content and shrink, leaving a space between the joists and the floor panels. To combat floor squeaks, re-nail with ring-shank nails after the panels and floor framing are dry. Squeaks may also happen where cross-blocking or bridging occurs between floor joists and between walls and floors. Precautionary re-nailing at those points may be advisable if they will be inaccessible after the remediation. See *APA Technical Note: Floor Squeaks—Causes, Solutions and Prevention*, Form C468.

How to Tell if Plywood is Delaminated?

Delamination is a separation of the individual “plies” or veneers in plywood. This condition is not common. Dry delaminated floor panels may feel soft or spongy when stepped on. The face ply may appear blistered or wrinkled. If you suspect delamination, walk over the areas of concern after the plywood is dry. Panels with extensive soft spots may need replacement. Localized swelling or blistering over knotholes and core gaps is not delamination and does not compromise the structural integrity of the panel. If necessary, blisters over knotholes may be repaired by injecting glue under the affected areas. It may be possible to repair delaminated plywood panels using the instructions in *APA Technical Note: Field Repairs of Plywood*, Form J805.

Will Plywood Delaminate at Some Future Date?

It is not likely. Subsequent soakings seldom cause additional delamination.

Following Flood Events

As noted previously, this publication does not address potential health concerns or indoor air quality after flooding. More information on these topics is available from the Federal Emergency Management Agency (FEMA) and the American Red Cross, such as *Repairing Your Flooded Home*, FEMA P-234. *Note: Extensive flood damage may require professional services to assess and repair wood construction.*

FAQs: Questions About Wood Structural Panel Exposure to Excessive Moisture

The main difference in water events during construction and after a building is finished, when it may be affected by a flood or other major water event such as a broken plumbing line, is the need to remove finish materials and insulation so that wet structural components can be exposed. Unless these finish materials are removed, the underlying structure is not able to properly dry out. If the structure does not dry out, it will not be able to retain structural integrity, and decay can set in.

Fungal Decay Prevention

Once flood water recedes, fungal decay organisms are presented with an ideal moisture condition. Therefore, it is important that wood products dry as soon as possible to ensure that the wood decay does not affect structural capacity. Note that mold and mildew are not decay organisms. These steps help to preserve a sound structure:

1. Clean out all mud and debris in contact with panels, studs, joists and beams. This will allow the wood to dry and permit inspection for structural damage.
2. Remove carpeting, pad and vinyl. This is vital to allow the panels to dry.
3. Remove wet interior finish (such as gypsum wallboard) from walls. Remove wet insulation and clean out any mud and debris. This will encourage free air circulation to speed the drying process.
4. Remove wet insulation from crawl spaces and the attic, if it is wet.
5. Remove standing water from crawl spaces. Standing water will prevent floors from drying.
6. Open up any other wet cavities to allow air to circulate freely.
7. Finally, make every effort possible to speed the drying process. Drying speed is relative to the thickness of the wood being dried, the humidity, the air temperature and the amount of air circulation. Heating the structure, if possible, will greatly speed drying. Do not use portable propane heaters to provide heat, as they add moisture to the air and increase drying time. Use fans and dehumidifiers to help move the air. If heat or dehumidifiers are not available, open doors and windows to encourage air circulation. Depending on conditions, the drying process can take from a week or two to several months.

How to Tell if Panels are Dry?

The use of a calibrated moisture meter is the easiest way to determine moisture content. Panels are dry when the moisture content is 15% or less, and usually safe from the threat of decay when 20% or less. Most general contractors and flooring installers have meters. Moisture meters can also be ordered from a contractor supply or hardware store.

What About Odors?

Mud may contain sewage or microorganisms. To minimize the possibility of odor problems, hose out all wall cavities and connection joints, such as between wall studs and bottom plates. Other common causes of odor are mold and mildew. To minimize this potential, thoroughly dry all concealed spaces and follow FEMA guidelines.

FAQs: Questions About Wood Structural Panel Exposure to Excessive Moisture

Other APA References

1. *Build A Better Home: Controlling Mold and Mildew*, Form A525
2. *Research Report: Plywood in Hostile Environments*, Form Z820
3. *Technical Note: Buckling of Wood-Based Panel Siding*, Form F410
4. *Technical Note: Condensation—Causes and Control*, Form X485
5. *Technical Note: Controlling Decay in Wood Construction*, Form R495
6. *Technical Note: Field Repairs of Plywood*, Form J805
7. *Technical Note: Floor Squeaks—Causes, Solutions and Prevention*, Form C468
8. *Technical Note: Mildew Discoloration of Wood Siding*, Form L805
9. *Technical Note: Minimizing Buckling of Wood Structural Panels*, Form D481

Questions About Wood Structural Panel Exposure to Excessive Moisture

We have field representatives in many major U.S. cities and in Canada who can help answer questions involving APA trademarked products. For additional assistance in specifying engineered wood products, contact us:

APA HEADQUARTERS

7011 So. 10th St. • Tacoma, Washington 98466
(253) 565-6600 • Fax: (253) 565-7265

PRODUCT SUPPORT HELP DESK

(253) 620-7400 • help@apawood.org

DISCLAIMER

The information contained herein is based on APA – The Engineered Wood Association's continuing programs of laboratory testing, product research, and comprehensive field experience. Neither APA, nor its members make any warranty, expressed or implied, or assume any legal liability or responsibility for the use, application of, and/or reference to opinions, findings, conclusions, or recommendations included in this publication. Consult your local jurisdiction or design professional to assure compliance with code, construction, and performance requirements. Because APA has no control over quality of workmanship or the conditions under which engineered wood products are used, it cannot accept responsibility for product performance or designs as actually constructed.

www.apawood.org

Form No. X501D/Revised May 2021

© 2021 APA – The Engineered Wood Association

SUBJECT: SEALING PREMIER SIPS

Building science has taught us that a tight building envelope significantly contributes to the energy efficiency of the structure. Building science has also shown us that SIPs can significantly reduce air leakage through the building envelop. This reduction in air leakage significantly contributes to the energy efficiency of a SIP structure.

If a structure using Premier SIPS is going to achieve reduced air leakage that contributes to the energy efficiency of the SIP system, the details relating to the sealing of SIP joints and connections needs to be followed. Designers and contractors are encouraged to become thoroughly familiar with the Premier SIPS technical bulletins and details that describe proper use of Premier SIPS Sealant and SIP tape.

Please refer to the Premier SIPS Resource Manual for illustrations of Premier SIPS Sealant and SIP Tape installation. The Resource Manual, Details and Instructional Videos demonstrating Premier SIPS Sealant and SIP Tape installation can all be found at www.premiersips.com.

Low expanding foam sealants compatible with the rigid insulation core (EPS) must be used to seal penetrations cut into Premier SIPS during the construction process. This would include any penetrations from the construction process, as well as penetrations for the HVAC, plumbing and electrical systems. These penetrations need to be thoroughly and completely sealed. Proper sealing of the electrical chases in Premier SIPS, as well as the electrical boxes within the Premier SIPS, would be part of the Premier SIPS sealing process.

Giving proper attention to the sealing of penetrations, SIP joints, and connections in your Premier SIPS structure will ensure that the structure has minimal air leakage through the exterior envelope, helping to maximize the energy efficiency of the Premier SIPS high performance envelope.

SUBJECT: SEALING REQUIREMENTS FOR SIPS USED IN COMMERCIAL APPLICATIONS

The purpose of this technical bulletin is to provide guidelines for the use of vapor retarders, Premier SIPS Sealant and Tape for SIPS used in commercial applications.

Building Codes require that for commercial structures where a whole building ventilation system is not installed, insulated framed walls, floors and ceilings must have vapor retarders installed on either the interior or exterior based on code requirements and local climate conditions

In commercial structures that do not meet the ventilation requirements of the building code, Premier SIPS recommends that the building code within the local jurisdiction be followed regarding installing a vapor retarder. If a vapor retarder is required in your commercial project, Premier Building Systems recommends the use of Premier SIPS Tape over the panel joints. Premier SIPS Tape is formulated with a permeance of less than 1.

Buildings with intended uses involving pools, spas, or other high humidity conditions need to be evaluated by the mechanical design professional in order that adequate ventilation is provided to the structure. In high humidity environments special attention to SIP joint sealing, tape or the use of a vapor retarded must be considered. The use of a complete wall and or roof surface coverage vapor retarder, such as polyethylene sheeting, may be warranted based on the structure's exposure to interior high humidity, local building code or climatic conditions. It is up to the design professional to make this determination. If an additional vapor retarder is utilized, it must be installed in compliance with the appropriate local building code.

That said, most commercial applications address ventilation by installing mechanical air handling and heating/cooling equipment. A mechanical engineer or HVAC consultant is always involved with the design of the ventilation system for commercial buildings. The mechanical engineer's design will determine the amount of ventilation the structure requires, based on the intended use of the building. In most applications the ventilation system provides for numerous air changes which may preclude the need for Premier SIPS Tape or other vapor retarders.

In addition, commercial structures intended to be used for storage or general warehouse may not require additional vapor control methods.

TECHNICAL BULLETIN NO. M-2

Reference Premier Technical Bulletin, Vapor Retarders with Premier SIPS, for more information on Premier SIPS Tape.

Premier SIPS Detail #PBS-105, 105A and 105B specify the use and application of SIP Tape at all joints. A minimum of 2" SIP Tape adhesion to SIP facings at each side of joint is required.

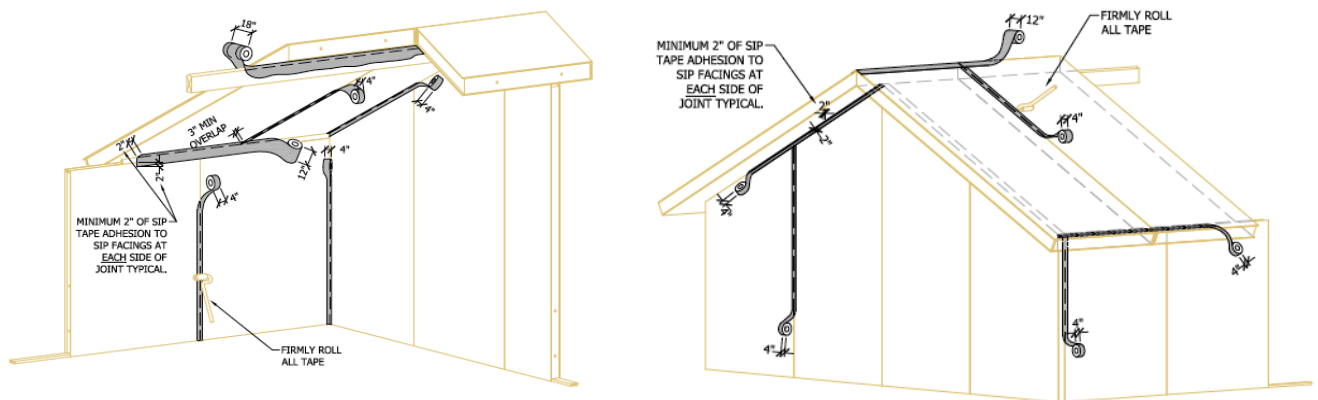

Refer to the Premier SIPS Resource Manual, Details and Instructional Videos demonstrating Premier SIPS Sealant and SIP Tape installation. These can be found at www.premiersips.com/sealant.

SUBJECT: VAPOR RETARDERS WITH PREMIER SIPS

Questions about using vapor retarders in conjunction with Premier SIPS are frequently asked. Premier SIPS installation requires the proper application of Premier SIPS Sealant and Tape over SIP joints. The function of the SIP Sealant and SIP Tape is to provide a seal against water vapor transmission and air passing through the SIP joint.

The purpose of this technical bulletin is to provide guidelines for the use of vapor retarders with Premier SIPS in residential applications.

THE INTERNATIONAL RESIDENTIAL CODE (IRC) REQUIRES:

SECTION R318 - MOISTURE VAPOR RETARDERS

R318.1 Moisture control: In all framed walls, floors and roof/ceilings comprising elements of the building thermal envelope, a vapor retarder shall be installed on the warm-in-winter side of the insulation.

Exceptions:

- a. In construction where moisture or freezing will not damage the materials.
- b. Where the framed cavity or space is ventilated to allow moisture to escape.
- c. In counties identified as climate zones 1 through 4 in Table N1101.2.

THE IRC DEFINITION OF A VAPOR RETARDER IS:

VAPOR RETARDER: A vapor resistant material, membrane or covering such as foil, plastic sheeting, or insulation facing having a permeance rating of 1 perm or less, when tested in accordance with the desiccant method using Procedure A of ASTM E96. Vapor retarders limit the amount of moisture vapor that passes through a material or wall assembly.

TECHNICAL BULLETIN

NO. M-3

The APA has determined that OSB has a perm rating of less than 1 when relative humidity is under 40%. With the OSB skins of SIPs having a water vapor permeance rating of less than 1, the panel joint and boundaries become the primary areas of concern for water vapor transfer.

As mentioned earlier, Premier Building Systems requires that SIP Sealant be used in all SIP joints. After the SIP Sealant step is completed, (see Premier Details #PBS -103 & PBS-104) Premier recommends the use of Premier SIPS Tape over SIP joints (see Premier Details #PBS-105, 105A, and 105B). Premier SIP Tape has a water vapor permeance of less than 1. Therefore, the combination of the field coverage of OSB skins that SIPs provide and the addition of Premier SIP Tape over the SIP joints meets the building code requirements for a vapor retarder.

SIP roofs that have joints occurring on support beams require 18" wide SIP Tape draped over the support beam and tacked in-place. A ridge beam is an example of this condition. See Premier Detail #PBS 105A.

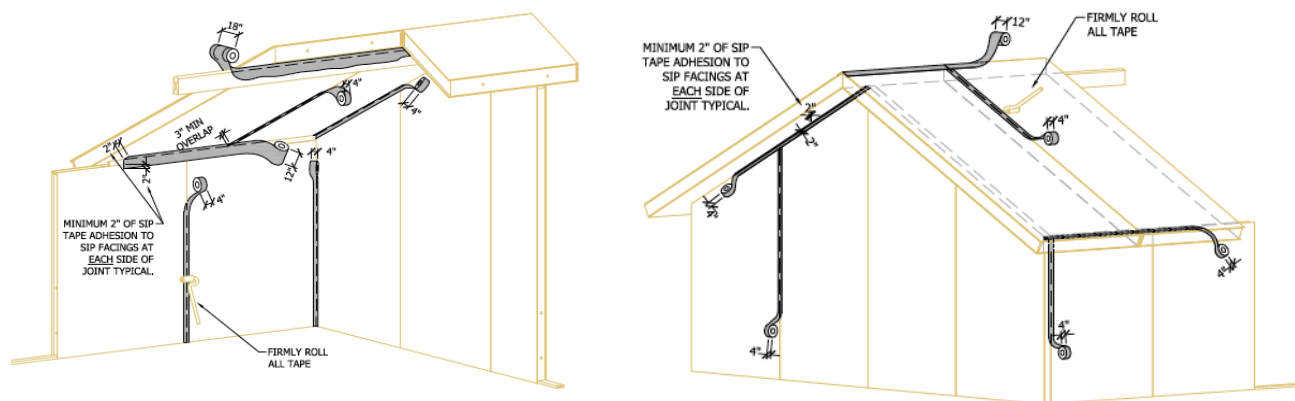

The use of a complete wall and or roof surface coverage vapor retarder, such as polyethylene sheeting, may be warranted based on the structure's exposure to interior high humidity, local building code or climatic conditions. It is up to the design professional to make this determination. If an additional vapor retarder is utilized, it must be installed in compliance with the appropriate local building code.

Refer to the Premier SIPS Resource Manual, Details and Instructional Videos demonstrating Premier SIPS Sealant and SIP Tape installation. These can be found at www.premiersips.com/sealant.

SUBJECT: WATER RESISTIVE BARRIERS OVER PREMIER SIPS

The purpose of this technical bulletin is to provide guidelines for the use of Water-Resistive Barriers applied to the exterior of SIPs walls.

THE 2018 INTERNATIONAL RESIDENTIAL CODE (IRC) REQUIRES:

SECTION R703 – EXTERIOR COVERING

R703.1 General: Exterior walls shall provide the building with a weather-resistant exterior wall envelope. The exterior wall envelope shall include flashing as described in Section R703.8. The exterior wall envelope shall be designed and constructed in a manner that prevents the accumulation of water within the wall assembly by providing a water-resistant barrier behind the exterior veneer as required by Section R703.2 and a means of draining water that enters the assembly to the exterior.

THE 2018 INTERNATIONAL BUILDING CODE (IBC) REQUIRES:

SECTION 1403 – PERFORMANCE REQUIREMENTS

1403.2 Weather protection: Exterior walls shall provide the building with a weather-resistant exterior wall envelope. The exterior wall envelope shall include flashing, as described in Section 1405.3. The exterior wall envelope shall be designed and constructed in such a manner as to prevent the accumulation of water within the wall assembly by providing a water-resistant barrier behind the exterior veneer, as described in Section 1404.2, and a means for draining water that enters the assembly to the exterior...

PREMIER SIPS ICC ESR-4524 REPORT STATES:

“The exterior face of wall SIPs is required to be covered with a wall covering complying with the applicable code or recognized in a current ICC-ES evaluation report. A water-resistive barrier must be installed over the panels in accordance with IBC Section 1404.2, IRC Section R703.2, BNBC Section 1406.3.6, and UBC Section 1402, as applicable, prior to application of the wall covering. Where Portland cement plaster is used, compliance with IBC Sections 2510 and 2512, IRC Section R703.6.3 or UBC Section 2506.4, as applicable, is necessary. All exterior panel joints must be sealed with a compatible acrylic latex caulk.”

THE IRC AND IBS DEFINITION OF A WATER-RESISTIVE BARRIER IS:

Water-Resistive Barrier: A material behind an exterior wall covering intended to resist liquid water that has penetrated behind the exterior covering from further intruding into the exterior wall assembly.

Therefore, Premier Building Systems recommends that a water-resistive barrier recognized by ICC-ES be installed over Premier SIPS used as exterior walls.

Current ICC-ES report holders for water-resistive barriers can be obtained by visiting the ICC-ES website at www.icc-es.org and navigating to Evaluation Reports, CSI List, Section 0728 – Water-Resistive Barriers.

**SUBJECT: MOISTURE CONTENT OF LUMBER USED WITHIN
PREMIER SIPS**

Integral to the construction of a Premier SIPS structure is the lumber used as plating and splines within the SIPs. Premier SIPS are designed to be used with kiln dried lumber. Therefore, Premier SIPS recommends the use of kiln dried lumber that has a moisture content at or below 12%. The reason for this requirement is to minimize any shrinkage of the lumber used within the SIPs, thus reducing the potential for unsealed gaps and cracks.

It is reported within the Forest Products Laboratory's Wood Handbook, Chapter 12, that lumber with a moisture content greater than 19%, may see considerable shrinkage as the lumber dries down to an equilibrium moisture content less than 19%. If this shrinkage occurs within a SIP plate pocket, gaps or cracks may open that provide a pathway for the movement of air. This air may contain moisture and if this moisture laden air meets a surface, with a temperature at or below the dew point of the air, condensation will occur. The use of lumber, with a moisture content of 12% or less will thereby provide a reasonable safety factor to reduce the potential for lumber shrinkage and minimize issues associated with lumber shrinkage.

SUBJECT: FRAMEGUARD - MOLD RESISTANT SIPS

Premier SIPS, when coated with FrameGuard®, provide protection against mold, fungal decay and termite damage to the oriented strand board (OSB) facings. An important aspect of choosing a mold, fungal decay and termite resistant coating for a SIP panel is to understand the regulatory, manufacturing, testing, air quality and warranty details of the system. EPA Registration is a critical regulatory issue in that all chemicals and components claiming to provide protection against mold, fungal decay and termites must be registered with the Environmental Protection Agency (EPA). The moldecide component of FrameGuard coating is covered by EPA registration # 72616-1-62190 and the termite resistant component is covered by EPA registration # 64405-1-62190. Other products may use an EPA registered component recognized for termites, but we recommend that you verify their registration with the EPA to ensure it includes recognition for mold resistance.

QUALITY CONTROLLED MANUFACTURING

FrameGuard coating is a blend of components factory applied to SIPs with advanced manufacturing equipment and processes to provide thorough coverage to the surface of Premier SIPS. Quality control records are maintained and ongoing tests are conducted to ensure proper treatment.

INDEPENDENT TESTING - MOLD

The FrameGuard coating has been tested side by side with many other wood protection products claiming protection against mold. Testing was conducted by Forintek, an independent third-party agency recognized as a leader in wood protection testing. The testing followed ASTM D3273, “Standard Test Method for Resistance to Growth of Mold on the Surface of Interior Coatings in an Environmental Chamber”. This mold growth study examined coated and uncoated samples over eight weeks, at a temperature of 77oF, and a relative humidity of 100%. The product performance was rated on a scale from 0 (no mold) to 5 (complete mold coverage). The FrameGuard formulation was the clear leader in performance when compared against competitive products used to treat the wood facings of SIPs.

Mold Control Study Third Party Testing¹

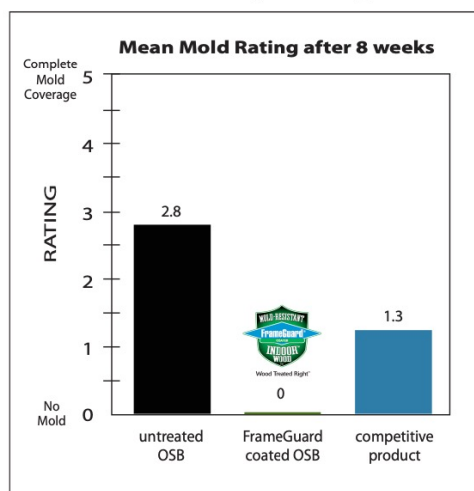

¹ Independent testing by Forintek Canada Corporation, using ASTM D-3273. Project 4528

WARRANTY COVERAGE

Premier SIPS sources the FrameGuard coating exclusively from Lonza/Arch Wood Protection, Inc. The FrameGuard limited warranty (see the warranty document for details) is backed by your Premier SIPS supplier and Lonza/Arch Wood Protection, Inc. You can be assured the warranty protection is backed by companies with a long history of performance servicing the SIP and wood protection markets. Lonza, the parent company of Lonza/Arch Wood Protection, is an international leader in biocides with over \$3.5 billion in sales. There is no cost for your FrameGuard limited warranty nor are there any special registration requirements. Some other competitive products may charge a fee for their warranty and require registration.

FrameGuard® is a registered trademark of Arch Wood Protection, Inc.

SUBJECT: VENTING OF PREMIER SIPS USED IN ROOFS

Even though Premier SIPS have been used in unvented roof applications since the 1960's, confusion still exists about the need to vent SIPs used as an insulated roof structure.

The building codes require ventilation of “enclosed attics and enclosed rafter spaces which are formed where ceilings are applied directly to the underside of roof rafters.” The building code defines an attic as the unfinished space between the ceiling joists of the top story and the roof rafters. When SIPs are used on a project where the SIPs are the exterior insulated roof envelop of the structure, a non-conditioned attic space does not exist. Like the rest of the structure, this is now considered a conditioned space. Therefore, roof ventilation is not required in a SIP roof structure.

IRC Section R806.4 furthers the discussion by addressing “unvented conditioned attic assemblies (spaces between the ceiling joists of the top story and the roof rafters ...)”. But, again, when SIPs are used on, or as the insulated roof structure, a non-conditioned attic space is not present.

Based on the information presented above, roof venting of Premier SIPS roof structures is not required. Please refer to Premier SIPS Technical Bulletin #27 for Mechanical Ventilation of SIP structures.

Current Premier SIPS Technical Bulletins can be found in the Premier SIPS Resource Manual or at www.premiersips.com.

SUBJECT: ROOF SIPS IN CANTILEVER CONDITIONS

Premier SIPS are used in many applications in which the SIPS create the eave and gable end overhangs of the roof. The use of SIPS to create the overhangs for eaves and gables is advantageous because it speeds the construction of the project and saves labor costs associated with hand framing.

Premier SIPS have been evaluated through a series of full-scale destructive tests at an independent, code recognized laboratory to determine the capabilities of SIPS in cantilever applications. These full-scale tests followed ASTM E-72 parameters for loading and monitoring deflection of the tested SIPS. The following addresses the capabilities of Premier SIPS when installed in a cantilever application for roof overhangs.

When evaluating overhangs or cantilevers, consideration must be given as to how the SIP cantilever is oriented in relation to the SIP span between supports. The two cantilever orientations that are possible include parallel and perpendicular to the SIP span. SIP cantilevers that are parallel to the SIP span can support greater overhangs with the use of structural I-Joist or Double 2x splines.

At SIP roof corner overhangs, SIPS simultaneously cantilever both parallel and perpendicular in relation to the SIP span. Where cantilevering perpendicular to the SIP span, utilize the Block Spline support loads indicated in the “Cantilevered Roof SIPS Type S Spline Capacity” table on next page (TABLE 1).

SIPS that are spanning both parallel and perpendicular to the SIP span are subject to two conditions:

1. The overall SIP width must be a minimum of two times the perpendicular cantilever
2. The back span of the parallel cantilever (‘Y’ dimension in FIGURE 1) must be a minimum of two times the cantilever (‘X’ dimension in FIGURE 1)

Unless engineered, the maximum cantilever oriented perpendicular to the SIP span is 4’.

In situations where increased loads are required or where an overhang greater than 4’ is desired, I-Joists (See Detail #PBS-203) or double 2x (Detail #PBS-205) splines can be used in conjunction with the “Cantilevered Roof SIPS Type “L” or Type “I” Spline Capacity” table on following pages (TABLE 2).

These I-Joist and double 2x spline cantilevers are subject to two conditions:

1. The cantilever must be parallel to the SIP span
2. The back span of the cantilever ('Y' dimension in FIGURE 2) must be a minimum of two times the cantilever ('X' dimension in FIGURE 2)

When Premier SIPs utilize I-Joist (Detail #PBS-203) or double 2x (Detail #PBS-205) splines at a frequency of 4' O.C., overhangs of up to 6' of horizontal projection are possible. Greater loads can be achieved if the spline frequency is increased to 2' O.C. Refer to the "Cantilevered Roof SIPs Type S Spline Capacity" table below (TABLE 1) for determining the cantilever capacities oriented perpendicular to the SIP span.

FIGURE 1
Type S (Block) Spline

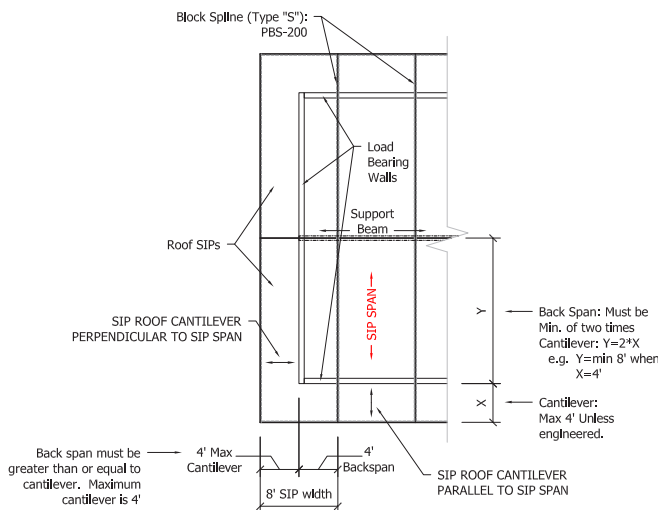
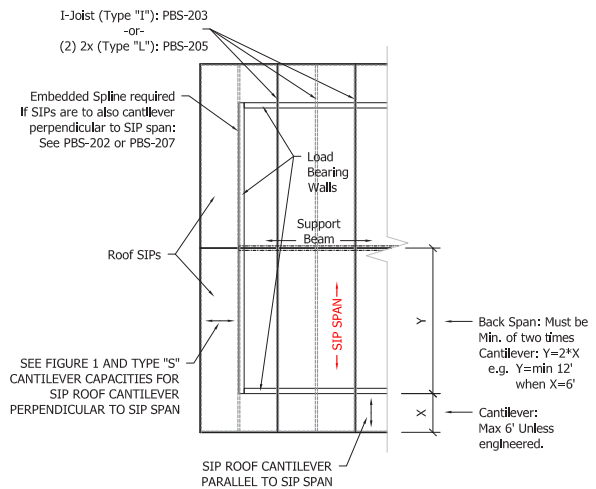

FIGURE 2
Type I (I-Joist) Spline OR
Type L (2X Lumber) Spline



CANTILEVERED ROOF SIPs TYPE S
SPLINE CAPACITY (PSF) - TABLE 1

SIP Thickness	Type S Spline	
	2' Maximum Cantilever	4' Maximum Cantilever
4 1/2"	81*	41*
6 1/2"	114*	57*
8 1/4"	149*	75*
10 1/4"	161*	81*
12 1/4"	166*	83*

CANTILEVERED ROOF SIPS TYPE L/TYPE I
SPLINE CAPACITY (PSF) - TABLE 2

SIP Thickness	Type L or I Spline with splines 4' o.c.		Type L or I Spline with splines 2' o.c.	
	4' cantilever with minimum 8' back span	6' cantilever with minimum 12' back span	4' cantilever with minimum 8' back span	6' cantilever with minimum 12' back span
4 ½"	53*	54*	81*	53*
6 ½"	87*	67*	114*	87*
8 ¼"	115*	84*	149*	115*
10 ¼"	125*	91*	161*	125*
12 ¼"	129*	93*	166*	129*

* Value is less than the ultimate load divided by a safety factor of three.

SUBJECT: ROOFING UNDERLAYMENTS OVER PREMIER SIPS

One of the many benefits of building with Premier SIPS is speed of construction. Speed of roof installation is especially beneficial in climates where precipitation is prevalent. However, precipitation during installation and its effects on a SIP roof assembly and roofing materials should be fully understood and mitigated. Proper construction methodology and sequencing for the installation of roofing materials over SIPs, is to allow the OSB and the interior of the SIP joints to dry adequately, prior to the installation of the roofing underlayment.

When these conditions present themselves on your project, Premier SIPS perform best with the use of a synthetic, breathable roofing underlayment below the final roof covering material as an alternative to traditional 15# or 30# asphalt saturated or coated roofing felts. Breathable roofing underlayment's having perm ratings of 15 or higher are recommended. Breathable underlayment allows water vapor to pass through the membrane yet restricts the bulk water movement back through the membrane toward the OSB facer of the SIP roof deck.

The science behind a breathable underlayment is to allow water vapor, that gets trapped at the OSB interface to pass through the synthetic roofing underlayment and once on the exterior side of the membrane it can condensate on the underside of the roofing material and run off the roof.

Adhered underlayment can be used on sloped roofs as code recognized ice barriers for roof eaves, valleys and gables. When adhered underlayment is used over a Premier SIPS roof deck, they should be vapor permeable and applied over a first layer of vapor permeable underlayment, nail applied to the SIPs roof deck.

There are many manufactures of breathable underlayment's in North America. A quick internet search will turn up manufactures and suppliers available to supply your project. Be sure you: verify with the manufacture that the perm rating of their breathable underlayment is 15 or greater and that their breathable underlayment is compatible with the roofing materials you intend to install on your SIPs project.

Following is a partial list of Vapor Permeable Underlayment* manufacturers you may contact to learn about their products:

TECHNICAL BULLETIN

NO. R-3



1. Vapro Shield – SlopeShield® Plus Self Adhered
www.vaproshield.com
2. Malarky Roofing Products – Secure Start® Permeable
www.malarkyroofing.com
3. GAF – Deck-Armor™
www.gaf.com/en-us/products/deck-armor
4. ACGI - USP Underlayments
<https://allenconsultinggroup.net>
5. DELTA®-FOXX
www.dorcken.com/en/our-products/products/residential/delta-foxx.php

*Premier SIPS has no business relationship, financial interest or involvement in the performance or warranty claims made by the companies listed above. It is the responsibility of our customer to research the information obtained from these companies and make their own determination for the suitability of the products listed above, when used with Premier SIPS.

SUBJECT: ASPHALT SHINGLES APPLIES TO SIP ROOF SUBSTRATES

GAF, a leader in the manufacture of asphalt shingles, examined the use of their shingles with SIPs and have authored the attached Technical Advisory Bulletin. GAF served notice that their, products applied directly over SIP substrates are acceptable and that no restrictions will be placed on their warranty.

GAF shingles are recommended as the preferred asphalt shingle product for use with Premier SIPS. When using shingles other than GAF, please contact your asphalt shingle manufacturer to clarify their warranty coverage when applied over SIP roof substrates.

TECHNICAL ADVISORY BULLETIN

To: GAF Residential Sales, GAF Contractors, GAF Field Services
From: Technical Services Department

Subject: Acceptable Substrate For GAF Asphalt Shingle Applications

Date: 07/31/2014

No: TAB-R 2011-101-R1

GAF Quality You Can Trust...
From North America's
Largest Roofing Manufacturer!

Why is The Substrate So Important?
A shingle roof substrate is the "foundation" for your roofing system. The substrate provides the smooth structural base on which asphalt shingles are installed. If the substrate is inferior, the integrity of the roofing system may be compromised.

What's Considered A "Standard Deck" For Shingles?
Standard decks include:

- Plywood or OSB... 3/8" minimum thickness, exterior grade as recommended by APA – The Engineered Wood Association
- Wood planking... Nominal 1" thick (min.) x 6" wide (max.) wood planking, with a maximum 1/8" spacing at the ends and sides

Note: For existing older installations, if spacing is > 1/8" ≤ 1/4", install a double layer of underlayment. If the spacing is greater than 1/4" install a layer of 3/8" minimum thickness APA labeled exterior grade plywood or OSB over the wood planking.

Can The Other Substrates Be Used Without Prior Approval?
When properly installed using the fasteners and construction design recommended by the deck manufacturer, the following substrates may be used:

- GAF Cornell ThermoCal® 1 Ventilating Roof Insulation Panels
- GAF Cornell ThermoCal® 2 Ventilating Roof Insulation Panels
- Loadmaster Shingle Deck
- Tech Shield or equivalent Radiant Barrier Decking systems with vapor permeable, perforated foil backing
- Ainsworth's Thermostrand Radiant Barrier
- 2" Minimum Homasote or ThermoSote (Homasote Co.)
- 2" Minimum Span Rock Gypsum Plank (USG) – fasteners must have a minimum 40 lbs. of pullout
- Vented-R (Atlas)
- Vented Nail-Line (Apache)
- Hunter Vented Nail Base
- Foam-Control Nail Base (AFM Corp. Licensed Mfr.)
- Tectum III, Tectum E and Tectum NS (Tectum, Inc.)
- Huber Zip Deck System – A waterproof underlayment such as StormGuard® leak barrier must be used at eaves as required by code or for certain warranty considerations and additional underlayment may be needed on slopes less than 4:12 or on re-roofing projects.

Note: GAF shingles are not approved for applications directly over any insulation or fiberboard.

What About Structural Insulated Panels (SIP)?
SIP may be use when:

- Approved/rated by UL for use as a shingle roof deck
- With the minimum thickness of plywood or OSB as recommended above installed in accordance with the SIP panel manufacturers recommendations for use as a shingle roof deck

What About Codes?
Roof decks must meet local codes... and approval from the local building department should be obtained to confirm the deck construction and ventilation meets local code requirements.

Is The Substrate Or Workmanship Covered Under GAF Warranties?
Only GAF Cornell ThermoCal® 1 & 2 Ventilating Roof Insulation Panels are covered by GAF under the GAF Cornell ThermoCal® Nail Base Roof Insulation Limited Warranty. See this limited warranty for complete coverage and restrictions.

Where Can I Get More Information?
All substrates must be installed in accordance with the deck manufacturer's specifications. Roof deck installation instructions, including the need for a vapor retarder, for specific deck types must be obtained from the respective manufacturer. GAF does not warrant the installation method, the performance of the decking or problems with the shingles caused by the deck or substrate, including but not limited to: physical movement, thermal bridging and/or moisture migration at the joints.

GAF Technical Services can assist you... with these and other questions you may have regarding your new roof installation. GAF Technical Services can be contacted at **800-ROOF-411 (800-766-3411)**. Also, the GAF website is a great resource for just about any question you may have or for additional information you may require. Please visit: www.gaf.com

SUBJECT: LOW SLOPE ROOFING OVER PREMIER SIPS

Low slope roofing systems are applied over Premier SIPS for both residential and commercial building applications and require that the architect and contractor applicator have a full understanding of the applicable code requirements and the performance of materials and systems.

Low slope roof applications typically utilize a single-ply roofing membrane, built up roof (BUR), or modified bitumen as the roofing system. Within these systems there are several techniques to secure the roof system to the roof deck. These include being ballasted, adhered, or mechanically attached. Ballasted systems rely on overlaid rock or cementitious pavers as a weight to hold the membrane in place. Adhered systems use asphalt or adhesives that are placed on the roof deck or carried on the membrane to adhere the membrane to the underlying roof deck. Solvent based adhesives are not approved by Premier Building Systems as they could cause deterioration of the Premier SIPS rigid insulation core. Water based adhesives are acceptable. In some attached systems, the adhesive layer is applied to a board or sheet known as a divorcement layer, that has been previously mechanically attached to the roof deck. Mechanical attachment is accomplished with the use of long screws through the membrane and insulation layers.

When Premier SIPS are used as the roof deck on a low slope roof system, Premier Building Systems requires that a divorcement material be placed over the SIPs prior to the roof membrane installation. This divorcement layer can be a slip sheet for ballasted systems, a nail applied base sheet for BUR systems, or a cover board such as gypsum, cement, or wood fiber for adhered systems. The application of these divorcement materials will obviate any damage to the top OSB structural skin of the SIP if the roof membrane system were to fail and/or need replacing. The OSB skins of a SIP are part of the SIP's structural component assembly, therefore the OSB skins must remain intact to provide long term structural capacity.

Further consideration needs to be given if the roof system needs to meet a Class A, B or C designation based on ASTM E108 or UL 790 testing. Premier SIPS are rated as a "combustible roof deck". Therefore, low slope roofing systems that can achieve a Class A, B or C rating over a combustible deck should be specified by the architect and installed by the roofing contractor.

TECHNICAL BULLETIN

NO. R-5



If a Class A rating over a SIPs combustible deck is specified, an acceptable and cost-effective method to achieve the Class A requirement is to apply a layer of gypsum or cementitious board over the SIPs. An example of a gypsum product is ¼” DensDeck®, that is mechanically attached to the SIPs. The attachment of the DensDeck needs to be sufficient to meet wind uplift requirements when used in conjunction with adhered membranes.

In addition to gypsum and cementitious board products, there are also fire rated membranes that can achieve Class A fire ratings when applied over combustible roof decks. In all cases, whatever divorcement material is used, it should meet the requirements of the roofing membrane manufacturer.

Therefore, Premier Building Systems requires that a Dens-Deck* (1/4” thickness or greater), or equivalently rated divorcement product in the type and style approved by the Low Slope Roofing System Manufacturer, be attached on top of the Premier SIPS roof deck prior to the installation of fully adhered systems. Mechanical attachment of the divorcement product shall be installed in accordance with the Low Slope Roofing Manufacturer’s recommendation when applied to a 7/16” OSB faced SIP roof deck system.

*DensDeck® is a registered trademark of Georgia Pacific.

SUBJECT: METAL ROOFING ATTACHMENT

Premier SIPS roofs can be finished with a wide range of roof covering systems. Metal roofing is one type of roof covering that has been used successfully over Premier SIPS for many years. Metal roofing provides a water-tight roof system and has a long-life expectancy when compared to many other roof claddings. One major advantage of metal roofing is that minimal maintenance is required over the life of the roof. As with all roof covering systems, the installation must comply with the metal roofing manufacturer’s recommended installation details.

The primary consideration when installing metal roofing over Premier SIPS is to ensure the metal roofing manufacturer provides installation recommendations for proper attachment into the 7/16” OSB facing of the Premier SIPS. Berridge Manufacturing Company, a leader in the metal roofing industry, provides installation recommendations for the attachment of their metal roof system directly into the 7/16” OSB facing of Premier SIPS. Following their installation recommendations provides assurance that the metal roof system will provide the long-term durability that is expected.

Premier Building Systems confirmed the strength of the Berridge attachment recommendations by testing the uplift resistance of Berridge 24-gauge Zee-Lock panel in accordance with UL 580, “Tests for Uplift Resistance of Roof Assemblies”. The tested assembly consisted of the Zee-Lock panel installed with a double lock, continuous Zee Rib, and #14 x 1-1/2 in. hex washer head Type A w/sealing washer from SFS Intec directly into the 7/16 in. OSB facing of the Premier SIPS. Two different fastening frequencies were evaluated.

Ultimate Pressure	Fastener Spacing
160 psf	14 in. o.c.
265 psf	8 in. o.c.

The test results clearly demonstrate that metal roofing can meet high wind uplift pressures when fastened directly into the 7/16 in. OSB of Premier SIPS. For further information regarding Berridge Manufacturing Company products, please visit www.berridge.com

TECHNICAL BULLETIN

NO. R-6



In addition, MBCI, another leader in the metal roofing industry can provide installation recommendations for the installation of their metal roofing products directly into the 7/16" OSB facing of Premier SIPS. Following the MBCI installation recommendations provides assurance that their metal roofing materials will provide long-term durability when their metal roofing is selected. For further information regarding MBCI Metal Roofing, please visit www.mbc.com

Similar performing metal roofing systems may be available in the marketplace. It is the responsibility of the designer and installer to determine if the manufacturer of these metal roofing systems recommends the use of their products and provide installation instructions and details for application when applied over SIP roof deck assemblies.

SUBJECT: VENTILATION OF METAL ROOFING WITH ENKAMAT

The ventilation of metal roofing when installed over Premier SIPS provides many building science benefits. The primary benefit of venting above a Premier SIPS roof deck is the removal of unintended moisture vapor that may emanate (known as “vapor drive”) from the interior of the building from the misapplication of Premier SIPS sealant and tape at spline joints and SIP to SIP intersections. The venting of moisture vapor between the metal roof covering and the top of the SIP roof deck reduces the risk of condensation and the potential of moisture damage of the SIPs upper skin. It should also be noted that vapor permeable underlayments should also be used in metal roof assemblies when applied over SIP roof decks (See Premier Technical Bulletins R3 & R6). In addition to the venting of interior moisture, any rainwater or melting snow that circumvents the metal roofing materials is also removed by virtue of the ventilation space.

Additional benefits of a ventilation cavity are: The reduction in the temperature of the SIPs upper skin from high heat generated by direct sunlight exposure in hot climate zones and the potential of concentrated heat from reflective surfaces, such as windows and reflective ponds. Metal roofing systems, particularly Zinc and Copper, can expose Premier SIPS roof decks to high temperatures and potential damage to its rigid insulation core. Underlayments can also be damaged by excessive heat exposure. The vented cavity keeps temperatures at the Premier SIPS roof surface within safe operating temperatures for both the SIP and underlayment. In winter, the ventilated space results in a cold roof, thereby reducing the potential for ice dams when the depth of snow on the roof is significant. Impact noise of rain and hail are mitigated as well.

Premier SIPS has investigated a unique product that is compatible with Premier SIPS for achieving a cost effective above the roof deck ventilation cavity - Colbond’s Enkamat 7020. Enkamat 7020 is commonly used in roofing applications to provide the ventilation, drainage, and thermal separation needed for the long service life of roof structures.



Enkamat 7020 from Colbond

Enkamat 7020 is a three-dimensional mat made of continuous nylon filaments fused at their intersections. The 95% open structure of the entangled filaments facilitates drying of condensed water vapor from the building interior, while giving full support to the metal roof. The nylon filaments do not fail under the load of the roof and the rigors of the construction environment, including construction foot traffic. The space created between the Premier SIPS roof deck and the roof covering will allow moisture to flow away or evaporate.

Testing has been conducted on the temperature difference that a Premier SIP surface experiences when ventilated with Enkamat 7020 when compared to no ventilation. A standing seam metal roof was applied over a Premier SIPS small scale roof structure for testing evaluation. Dark colored standing seam metal roof panels were fixed to the SIPs roof over the Enkamat 7020/roofing underlayment. An assembly of metal roof panels over roofing underlayment alone was also tested for comparison. The top surface of both metal roofing assemblies was brought to a temperature of 194° F (90° C) using infrared heat lamps. This temperature was held for 6 hours to ensure that temperatures moving through the assembly would stabilize.

The temperature recorded on the top surface of the Premier SIPS was reduced by 18% with the use of the Enkamat 7020. These results clearly demonstrate the effect of an air space lowering the temperature of a Premier SIPS roof deck, when metal roofing experiences solar exposure, resulting in high surface temperatures.

SIP Ventilation	Temperature Reduction from Metal Roof to Top Surface of Premier SIP
None	10°F
Enkamat 7020	43°F

Premier SIPS recommends Colbond's Enkamat 7020 as a product that provides the important benefit of easy, cost-effective installation over Premier SIPS, thereby achieving the additional building science benefits of ventilation: Cooling top of roof deck air temperature, allowing above roof deck evaporation of moisture and mitigating the sounds of rain and/or hail striking the metal roof.

Similar performing ventilating mats may be available in the marketplace. It is the responsibility of the designer and installer to determine if the manufacturer of these ventilating mats recommends the use of their products and provide installation instructions and details for application when applied over SIP roof deck assemblies.

SUBJECT: EXTERIOR CLADDING TO PREMIER SIPS WALLS

Premier SIPS are used in both commercial and residential applications. Throughout the years, Premier has had nearly every type of exterior cladding applied to the face of its SIPs. This bulletin is a review of common claddings that are available and their attachment to Premier SIPS. Premier SIPS do not incorporate framing members and therefore, require cladding materials that are approved to be installed over 7/16" Structural OSB Sheathing.

A review of the requirements for attachment of the siding material typically calls out for the cladding to be attached with 8d nails 16" or 24" on center depending on the framing spacing. Using these values, one can compare the pullout values for 8d nails into standard framing with the fastener pullout values listed in Premier's Technical Bulletins regarding Screw & Nail Withdrawal Capabilities of OSB. This comparison shows that all claddings, with the requirements of fastening to framing members, can be matched by applying 8d ring shank nails 12" o.c. into Premier SIPS. This would include the attachment of standard sidings such as vinyl, Hardie® Board, cedar, redwood, board metal, composites and fiber cement sidings.

This type of comparison is also valid for the application of lath for stucco as well as brick tie placement. Typically, these products are attached to SIPs by simply increasing the number of fasteners by 25%. When a manufacturer calls out for fasteners 16" o.c. the fasteners would be placed in a SIP panel at a spacing of 12" o.c. This will allow the panel application to meet or exceed the pull-out values required by the siding manufacturer. It should be noted that the fastener placement can be maintained at the siding manufacturer's recommendations provided a nail/staple is replaced with a screw. In all cases the fastener should be corrosion resistant.

FIBER CEMENT BOARD SIDING MANUFACTURERS & SIPS

James Hardie, Allura and Nichiha are the leading manufacturers of fiber cement board siding supplied throughout the US and Canada. Each of these companies has examined the use of their products when applied over Premier SIPS. All three of these companies have provided notice that their products, when applied directly over the 7/16" OSB facing of SIPs are acceptable by following their recommended attachment patterns and approved fasteners.

James Hardie, Allura and Nichiha sidings are recommended as premium fiber cement board siding products compatible with Premier SIPS. Information on the attachment requirement for each of these companies can be found at:

James Hardie
www.jameshardie.com
ICC-ES Evaluation Reports
ESR-2290 and ESR-1844

Allura
www.allurausa.com
ICC-ES Evaluation Report ESR-1668

Nichiha
www.nichiha.com
Intertek CCRR-0258

SIPS & ENGINEERED WOOD LAP SIDING FROM LOUISIANA PACIFIC

Louisiana-Pacific, a leader in the manufacture of Engineered Wood lap siding, has examined the use of their Smartside Precision Treated Engineered Wood lap siding with SIPs. Louisiana-Pacific worked with APA who authored the APA Product Report ([PR-N124 Available Here](#)). Louisiana-Pacific has served notice that their products applied directly over Premier SIPS are acceptable when following their recommended fastening patterns. Louisiana-Pacific siding is recommended as a premium Engineered-Wood lap siding product compatible with Premier SIPS.

Information regarding the attachment requirements for Louisiana-Pacific's Engineered Wood lap siding can be found in the PR-N124 APA Product Report linked above. Tables 4a and 4b list specific SIP attachment recommendations, and these tables are attached to this bulletin.

For further information on Louisiana-Pacific siding products, please visit www.lpsmartside.com, Engineered Wood Lap Siding from Louisiana-Pacific.

SUBJECT: EIFS & PREMIER SIPS

Premier SIPS structures can be finished with any code approved weather covering. Exterior Insulation Finish Systems (EIFS) are one type of code recognized weather covering. EIFS provide watertight protection and have been used successfully over Premier SIPS structures for many years. It is recommended that EIFS intended for use over OSB substrates be used. EIFS system installers must follow the EIFS Manufacturer's installation guidelines to achieve a warranted outcome.

Various code jurisdictions require that the EIFS being installed include a water drainage system. Many EIFS Manufacturers have systems that meet this requirement.

STO SYSTEM:

Sto Corp. has developed StoTherm® ci, a water managed EIFS, utilizing an air/moisture barrier system that works exceptionally well over Premier SIPS. The Sto system features benefits that enhance the long-term performance of Premier SIPS:

1. Premier SIPS OSB skins and penetrations are moisture protected.
2. StoTherm ci is adhesively applied – Results in a perfectly air and water tight surface coating over the SIP exterior skin.
3. Incidental water that may get behind the EIFS is drained outside the system.

This Technical Bulletin gives guidelines for the application of the StoTherm ci with StoGuard® Moisture Protection when applied over Premier SIPS.

GENERAL CAUTION:

StoGuard protects the Premier SIPS OSB facings from moisture damage during the construction phase, as well as in service protection in the event of a moisture breach in the EIFS wall cladding. Proper application is required of the installer. Application of the StoGuard over Premier SIPS is not intended to correct faulty workmanship. It is essential that proper flashing and details be integrated into the design that direct water to the outside of the cladding system. Defective components of construction, such as leaky windows and doors, should not be used.

APPLICATION RECOMMENDATIONS:

Sto Corp. publishes complete specifications for the installation of their StoGuard and StoTherm ci. The following recommendations are being provided as they apply to installations over Premier SIPS. Prior to starting any work, completely read all specifications and installation guidelines.

STEP 1:

Clean Premier SIPS OSB facing surfaces that are to receive the StoGuard Moisture Protection System. Premier SIPS OSB surfaces must be in good condition, free of dirt and all bond inhibiting contaminants. Surfaces must be dry, with the ambient air temperature at 40o F and rising before application can occur.

STEP 2:

Apply Sto Gold Coat® to the entire exterior Premier SIPS OSB facing receiving the Sto EIFS. Using a 3/4" (19mm) nap roller, apply Sto Gold Coat in a uniform wet thickness coating of 10 mils. Protect from weather and temperature until dry.

STEP 3:

Premier SIPS joints, rough openings, corners, and tops of wall parapets are filled and covered with Sto Gold Fill® and StoGuard Mesh, embedded into the Sto Gold Fill (additional Sto joint and rough-opening material options are listed at www.stocorp.com). Fastener and surface defects must be spot filled with Sto Gold Fill. Application is by trowel with maximum thickness on the Premier SIPS OSB surface being 1/16". Joints require a 4" minimum width mesh. Rough openings, corners and parapets require a 9" minimum width mesh detail.

STEP 4:

Re-apply a second coat of Sto Gold Coat over the entire Premier SIPS OSB facing receiving the Sto EIFS, including all surfaces previously covered with Sto Gold Fill. Using a 3/4" (19mm) nap roller, apply Sto Gold Coat in a uniform wet thickness coating of 10 mils. Protect from weather and temperature until dry.

STEP 5:

Coordinate the proper installation of flashing and other moisture protection components, such as windows, doors, fireplaces, chimneys and other like penetrations that impact the water tightness of the StoTherm ci applied over the Premier SIPS.

TECHNICAL BULLETIN

NO. W-2

STEP 6:

Install the StoTherm ci System per the manufacturer’s detailed specifications and installation guidelines including all accessories such as, but not limited to: Starter Track, Window/ Door Head Flashing, Side Wall Step Flashing, Backwrapping, adhesive and EPS Insulation Board, Trim and Reveals, Base Coat and Reinforcing Mesh, Primer and Finish Coat.

NOTE:

This Technical Bulletin presents applications using Sto Gold Fill, StoGuard Mesh and the StoTherm ci System. Information regarding other Sto products and systems options are available at www.stocorp.com.

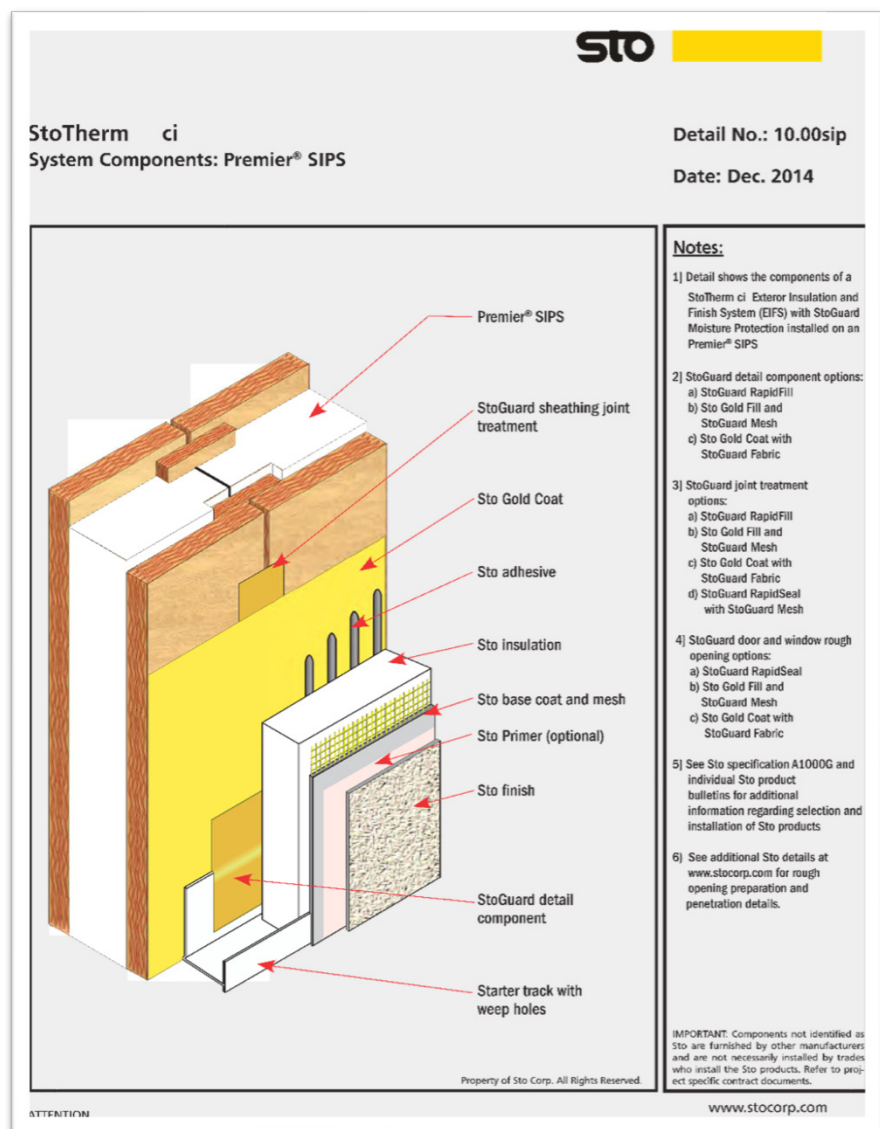

Construction Details

Faster. Stronger. Greener.



Website: premiersips.com

Toll Free: 800-275-7086

Details, illustrations, pictures, and guidelines provided in this Resource Manual give basic information and illustrate examples of Premier SIPS design & installation recommendations. The basic information provided herein is not intended to cover every potential use and application of Premier SIPS. It is the responsibility of the owner and/or the owner's representative to design the insulated wall assembly to perform in a manner ensuring function and durability. Adding an additional insulation component may change the behavior of a wall assembly regarding air movement, water vapor transmittance, bulk water management, and heating, cooling, and ventilation systems. It is the responsibility of the installer to become familiar with each specific application and determine if Premier SIPS are suitable. By commencing work, the installer accepts full responsibility for the proper and safe installation of Premier SIPS at each job site. Furthermore, it is the sole responsibility of the installer to meet all federal and local regulatory requirements for job site safety for every person on the job site while in the execution of all phases of the SIP installation.

CONSTRUCTION DETAILS

GENERAL DETAILS

PBS-100S PBS ESR-4524, ESL-1207, & ESL-1208 SHEAR WALL ASSEMBLIES..... CD-4

PBS-100D PBS ESR-4524, IN-PLANE SHEAR FOR DIAPHRAGMS..... CD-5

PBS-101A SIP BEST PRACTICES EXAMPLES.....CD-6

PBS-101B SIP BEST PRACTICES NOTES..... CD-7

PBS-102 SIP THICKNESS AND R-VALUE..... CD-8

PBS-103 SIP SEALANT APPLICATION WALLS.....CD-9

PBS-104 SIP SEALANT APPLICATION ROOF..... CD-19

PBS-105 SIP TAPE APPLICATION NOTES..... CD-11

PBS-105A SIP TAPE APPLICATION INTERIOR..... CD-12

PBS-105B SIP TAPE APPLICATION EXTERIOR..... CD-13

PBS-106A WALL ELECTRICAL CHASES CORNER ROUTED THROUGH FLOOR..... CD-14

PBS-106B WALL ELECTRICAL CHASES CORNER ROUTED THROUGH EXTERIOR..... CD-15

PBS-107 ROOF ELECTRICAL CHASES..... CD-16

PBS-108 ELECTRICAL BOXES..... CD-17

PBS-109 SIP WALL FINISHES.....CD-18

PBS-110 SIP WALL INTERIOR DETAILS..... CD-19

PBS-111 SIP FURRING..... CD-20

PBS-112 VOID IN SIP WALL..... CD-21

PBS-113 SIP TO TIMBER FRAME DETAILS..... CD-22

PBS-114 SIP ROOF PENETRATIONS..... CD-23

PBS-115 CEILING FAN ATTACHEMENT.....CD-24

SPLINE DETAILS

PBS-200 BLOCK SPLINES..... CD-25

PBS-201A TYPE I (I-JOIST) SPLINE..... CD-26

PBS-201B TYPE I (I-JOIST) SPLINE SIP FOAM PROFILED..... CD-27

PBS-202 EMBEDDED I-JOIST SPLINE.....CD-28

PBS-203 I-JOIST SIP CONNECTION..... CD-29

PBS-204 2X SPLINE.....CD-30

PBS-205 2X SIP CONNECTION..... CD-31

PBS-206 LVL SPLINE..... CD-32

PBS-207 EMBEDDED LVL SPLINE..... CD-33

PBS-208 ALTERNATE LUMBER SPLINES.....CD-34

PBS-209 HSS 2X SPLINE..... CD-35

FOUNDATION DETAILS

PBS-300 CAPILLARY PLYWOOD SILL BOTTOM PLATE FOUNDATION CONNECTION	CD-36
PBS-301 CAPILLARY 2X SILL BOTTOM PLATE FOUNDATION CONNECTION	CD-37
PBS-302 CANTILEVERED SILL PLATE FOUNDATION CONNECTION	CD-38
PBS-303 BOTTOM PLATE	CD-39
PBS-304A-D BOTTOM PLATE FLOOR JOIST TO CONCRETE	CD-40
PBS-304E-H BOTTOM PLATE FLOOR JOISTS TO WALL	CD-41
PBS-305 BOTTOM PLATE PLACEMENT	CD-42
PBS-306 HDU TYPE HOLDOWN	CD-43
PBS-306A HDU TYPE HOLDOWN - INSTALLED PRIOR TO SIP	CD-44
PBS-307 STRAP HOLDOWN	CD-45
PBS-308 BOTTOM PLATE INSULATED RIM FOUNDATION CONNECTION	CD-46

WALL DETAILS

PBS-400 SIP WALL PLATE	CD-47
PBS-401 SIP WALL PLATE BEVELED TOP	CD-48
PBS-402 BEVELED SIP WALL PLATE TOP AND BOTTOM	CD-49
PBS-403 WALL CORNER	CD-50
PBS-404 WALL ANGLED CORNER	CD-51
PBS-405 CAP PLATE CONNECTION	CD-52
PBS-406 BEARING PLATE	CD-53
PBS-407 HEADER AT TOP OF SIP WALL ASSEMBLY SEQUENCE	CD-54
PBS-408 HEADER AT TOP OF OPENING ASSEMBLY SEQUENCE	CD-55
PBS-409 HEADER AT TOP OF OPENING LIMITED BEARING*ASSEMBLY SEQUENCE	CD-56
PBS-410 HEADER AT TOP OF TALL SIP WALL ASSEMBLY SEQUENCE	CD-57
PBS-411 HEADER ASSEMBLIES	CD-58
PBS-412 FACTORY CUT OPENINGS	CD-59
PBS-413 RTA OPENING ASSEMBLY SEQUENCE	CD-60
PBS-414 SIP BEAM POCKET AT TOP OF WALL WITH POST	CD-61
PBS-415 SIP BEAM POCKET AT TOP OF WALL WITHOUT POST	CD-62

WALL TO ROOF CONNECTION

PBS-500 SIP WALL TO ROOF BEVELED BLOCK	CD-63
PBS-501 SIP WALL TO ROOF BEVELED TOP OF WALL	CD-64
PBS-502 SIP WALL TO ROOF GABLE OVERHANG	CD-65
PBS-503 SIP WALL TO ROOF, NO OVERHANG BEVELED BLOCK	CD-66
PBS-504 SIP WALL TO ROOF, NO OVERHANG BEVELED TOP OF WALL	CD-67
PBS-505 SIP WALL TO ROOF GABLE NO OVERHANG	CD-68
PBS-506 SIP EAVE PLUMB CUT SIP	CD-69
PBS-507 SIP EAVE SQUARE CUT SIP	CD-70

PBS-508 PARAPET DETAIL.....	CD-71
PBS-509A-D LEDGER DETAILS SIP WALL.....	CD-72
PBS-509E-H LEDGER DETAILS SIP WALL.....	CD-73
PBS-509J LEDGER DETAILS SIP WALL.....	CD-74
PBS-510 LEDGER DETAILS STICK WALL.....	CD-75
PBS-511 SIP WALL & ROOF PLATFORM FRAMING PERPENDICULAR INTERSECTION....	CD-76
PBS-512 SIP WALL & ROOF PLATFORM FRAMING SLOPED INTERSECTION	CD-77

ROOF BEARING DETAILS









PBS-600A-C SIP BEARING CONDITIONS CONTINUOUS SIP	CD-78
PBS-600D-E SIP BEARING CONDITIONS CONTINUOUS SIP.....	CD-79
PBS-600F-G SIP BEARING CONDITIONS CONTINUOUS SIP	CD-80
PBS-600H SIP BEARING CONDITIONS CONTINUOUS SIP.....	CD-81
PBS-601A-D SIP BEARING CONDITIONS SIP JOINT.....	CD-82
PBS-601E-F SIP BEARING CONDITIONS SIP JOINT	CD-83

ROOF DETAILS

PBS-700 SIP FLOOR/ROOF PLATE.....	CD-84
PBS-701 BEVELED ROOF PLATE	CD-85
PBS-702 FLUSH FOAM ABOVE BEARING.....	CD-86
PBS-703 BLOCK SPLINES ABOVE BEARING.....	CD-87
PBS-704 ROOF BEAM FLUSH MOUNTED BEAM.....	CD-88
PBS-705 ROOF VALLEY BEVEL CUT	CD-89
PBS-706 ROOF VALLEY FLUSH FOAM BEVEL CUT	CD-90
PBS-707 ROOF VALLEY FLUSH MOUNTED VALLEY BEAM.....	CD-91
PBS-708 ROOF RIDGE/HIP FLUSH FOAM BEVEL CUT.....	CD-92
PBS-709 ROOF RIDGE - RIDGE CAP.....	CD-93
PBS-710 ROOF RIDGE OVERLAP	CD-94
PBS-711 ROOF RIDGE SIPS SPANNING PARALLEL TO RIDGE.....	CD-95
PBS-712 ROOF RIDGE FLUSH MOUNTED RIDGE BEAM	CD-96
PBS-713 ROOF RIDGE CANTILEVERED SIP	CD-97
PBS-714 ROOF RIDGE FLUSH FOAM PLUMB CUT AT DIFFERENT PITCHES	CD-98

FLOOR DETAILS

PBS-800 CAPILARY 2X SILL BOTTOM PLATE SIP FLOOR CONNECTION.....	CD-99
PBS-801 SIP FLOOR POINTLOAD BLOCING.....	CD-100
PBS-802 SIP PLATFORM FRAMING	CD-101

ALLOWABLE IN-PLANE RACKING SHEAR STRENGTH FOR SIP SHEAR WALLS 4 1/2" THROUGH 12 1/4" SIP THICKNESS WIND AND SEISMIC LOADS. ¹							
SPLINE TYPE ²	Mark	FRAMING MINIMUM SG ³	MINIMUM FACING CONNECTIONS ³			SHEAR STRENGTH ⁴ (plf)	SEISMIC DESIGN CATEGORIES
			Chord	Plate	Spline		
Block or Lumber Spline		0.50	0.113" x 2-1/2" nails, 6" O.C.	0.113" x 2-1/2" nails, 6" O.C.	(7/16" OSB - 3" Box/Block Spline) 0.113" x 2-1/2" nails, 6" O.C.	410	A,B,C ^{5,6}
		0.50	0.113" x 2-3/8" nails, 6" O.C. stagger (2 rows)	0.113" x 2-3/8" nails, 6" O.C.	(7/16" OSB - 3" Box/Block Spline) 0.113" x 2-3/8" nails, 6" O.C.	460	A,B,C ^{5,6}
		0.42	0.113" x 2-3/8" nails, 6" O.C. stagger (2 rows)	0.113" x 2-3/8" nails, 4" O.C. stagger (2 rows)	(7/16" OSB - 3" Box/Block Spline) 0.113" x 2-3/8" nails, 4" O.C.	700	A,B,C ^{5,6}
		0.42	0.148" x 2-3/8" nails, 6" O.C. stagger (2 rows)	0.148" x 2-3/8" nails, 3" O.C.	(23/32" OSB - 3" Box/Block Spline) 0.148" x 2-3/8" nails, 3" O.C. stagger (2 rows)	1000	A,B,C ^{5,6}
		0.50	0.113" x 2-1/4" nails, 6" O.C.	0.113" x 2-1/4" nails, 3" O.C.	(7/16" OSB - 3" Box/Block Spline) 0.113" x 2-1/2" nails, 6" O.C.	360	A,B,C,D, E,F ^{7,8,9}
		0.50	0.113" x 2-1/4" nails, 6" O.C.	0.113" x 2-1/4" nails, 6" O.C.	(23/32" OSB - 3" Box/Block Spline) 0.113" x 2-1/4" nails, 6" O.C.	360	A,B,C,D, E,F ^{7,8,9}
		0.50	0.113" x 2-3/8" nails, 3" O.C. stagger (2 rows)	0.113" x 2-3/8" round head nails, 3" o.c. stagger (2 rows)	(23/32" OSB - 3" Box/Block Spline) 0.113" x 2-3/8" nails, 3" O.C. stagger (2 rows)	720	A,B,C,D, E,F ^{7,8,10}
		0.50	0.113" x 2-3/8" nails, 2" O.C. stagger (2 rows)	0.113" x 2-3/8" round head nails, 2" o.c. stagger (2 rows)	(23/32" OSB - 3" Box/Block Spline) 0.113" x 2-3/8" nails, 2" O.C. stagger (2 rows)	920	A,B,C,D, E,F ^{7,8,10}

For **SI**: 1 inch = 25.4 mm; 1 plf = 14.6 N/m.

- Chords, holdowns and connections to other structural elements must be designed by a registered design professional in accordance with accepted engineering practice.
- Spline type at SIP-to-SIP joints, solid chord members are required at each end of each shear wall segment. When lumber splines are used they must be interconnected using 10d common nails [0.148-inch-diameter x 3 inches (3.8 mm x 76 mm)] spaced 5-inches (127 mm) on center. Lumber spline fastening to be verified by a registered design professional.
- Required connections must be made on each side of the SIP. Dimensional or engineered lumber shall have an equivalent specific gravity not less than specified.
- For design to resist seismic forces, shear wall height-width ratios greater than 2:1, but not exceeding 3.5:1, are permitted for assemblies using lumber splines provided the allowable shear strength values in this table are multiplied by 2w/h.
- Shear strength values, as published, are limited to assemblies resisting wind or seismic forces when the aspect ratio (height:width) does not exceed 2:1.
- Reference ICC-ES ESR-4524 Evaluation Report for additional Information.

SPECIFIC TO SEISMIC DESIGN CATEGORIES A,B,C,D,E AND F:

- Shear strength values are limited to assemblies resisting wind or seismic forces where the aspect ratio (height:width) does not exceed 1:1 for Type 'S' SIP connections or 2:1 for Type 'L' SIP connections.
- The shear wall configurations are permitted in Seismic Design Categories D,E, and F. Such walls shall be designed using the seismic design coefficients and limitations provided in ASCE 7 for light-framed walls sheathed with wood structural panels rated for shear resistance. These SIPs shall use the following factors for design: Response Modification Coefficient, R = 6.5; System Overstrength Factor, $\Omega_0 = 3.0$; Deflection Amplification Factor, $C_d = 4.0$.
- Reference ICC-ES ESL-1208 Listing Report for additional Information.
- Reference ICC-ES ESL-1207 Listing Report for additional Information.

N.T.S. Rev: 7/19/2022





PBS-100S

PBS ESR-4524, ESL-1207 & ESL-1208
ICC-ES SIP SHEAR WALL ASSEMBLIES

**PREMIER
SIPS**



**MAXIMUM ALLOWABLE IN-PLANE SHEAR
FOR DIAPHRAGMS SUBJECTED TO WIND OR SEISMIC LOADING¹**

MINIMUM CONNECTIONS ²					ALLOWABLE SHEAR LOAD (plf)	G' APPARENT SHEAR STIFFNESS (lbf/in)	MAXIMUM ASPECT RATIO
Mark	Interior Supports ² (Figure A)	Box/Block Spline ³ (Figure B)	Boundary ⁴ (Figure C)				
			Support	Spline			
	PBS No. 14 SIP Screw with 1" penetration 12" on center	0.113" x 2.5" nails, 3" on center, 7/16" OSB - 3" Box/Block Spline	PBS No. 14 SIP Screw with 1" penetration 12" on center	0.113" x 2.5" nails, 6" on center	430	24000	4:1
	PBS No. 14 SIP Screw with 1" penetration 12" on center	0.113" x 2.5" nails, 3" on center, 2 rows, staggered 7/16" OSB - 3" Box/Block Spline	PBS No. 14 SIP Screw with 1" penetration 3" on center	0.113" x 2.5" nails, 4" on center	460	30300	4:1
	PBS No. 14 SIP Screw with 1" penetration 2" on center	0.113" x 2.5" nails, 3" on center, 2 rows, staggered 7/16" OSB - 3" Box/Block Spline	PBS No. 14 SIP Screw with 1" penetration 2" on center	0.113" x 2.5" nails, 1.5" on center	655	41300	4:1
	PBS No. 14 SIP Screw with 1" penetration 4" on center	0.113" x 2.5" nails, 3" on center, 2 rows, staggered 7/16" OSB - 3" Box/Block Spline	PBS No. 14 SIP Screw with 1" penetration 4" on center	0.113" x 2.5" nails, 3" on center	795	93700	3:1
	PBS No. 14 SIP Screw with 1" penetration 4" on center	0.113" x 2.5" nails, 6" on center, 2 rows, staggered 23/32" OSB - 4" Box/Block Spline	PBS No. 14 SIP Screw with 1" penetration 4" on center	0.113" x 2.5" nails, 6" on center	1130	110600	3:1

For **SI**: 1 inch = 25.4 mm; 1 lb = 4.45 N; 1 plf = 14.6 N/m.

- The maximum diaphragm length-to-width ratio shall not exceed 4:1. Load may be applied parallel to continuous panel joints.
- Interior supports shall be spaced not to exceed 12 feet (3.66 m) on center and have a minimum width of 3 1/2 inches (88.9 mm) and a specific gravity of 0.42 or greater. Specified fasteners are required on both sides of panel joint where panels are joined over a support. See Figure A.
- Box/Block Spline fastened at top only, at interior panel-to-panel joints. Specified fasteners are required on both sides of panel joint. See Figure B.
- Boundary spline shall be solid 1 1/2 inches (38.1 mm) wide, minimum, and have a specific gravity of 0.42 or greater. Boundary supports shall have a minimum width of 3 1/2 inches (88.9 mm) and a specific gravity of 0.42 or greater. Specified spline fasteners are required through both facings. See Figure C.
- Diaphragms shall be specified in accordance with accepted engineering practices.

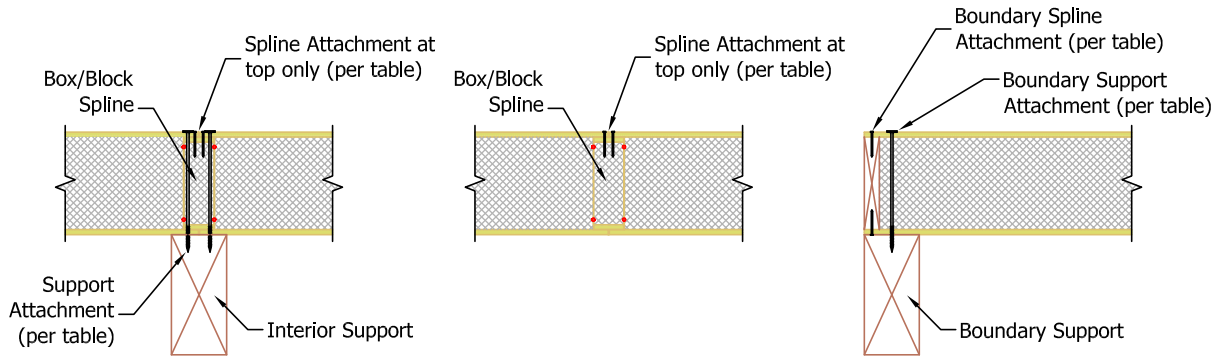

FIGURE A -
INTERIOR SUPPORT

FIGURE B -
BOX/BLOCK SPLINE

FIGURE C -
BOUNDARY

N.T.S.

Rev: 9/23/2022

PBS-100D

**PBS ESR-4524 ICC-ES
IN-PLANE SHEAR FOR DIAPHRAGMS**



BOTH SIP WALL FACINGS MUST HAVE FULL BEARING. EXTERIOR FACING MUST NOT HANG OVER EDGE OF FLOOR SYSTEM OR OTHER BEARING.

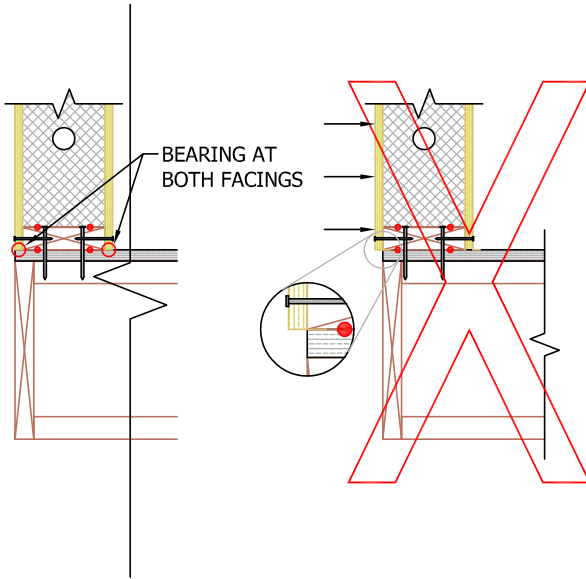

BOTH SIP WALL FACINGS CANNOT COME IN DIRECT CONTACT WITH CONCRETE. THERE MUST BE A CAPILLARY BREAK BETWEEN CONCRETE AND BOTH SIP FACINGS.

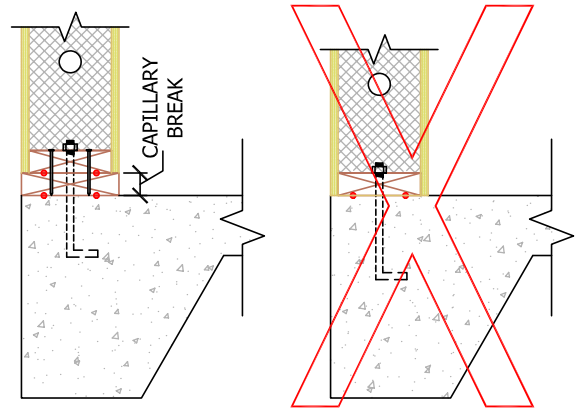

CAP PLATES INSTALLED TO TOP OF SIP WALL MUST BE FULL WIDTH OF SIP.

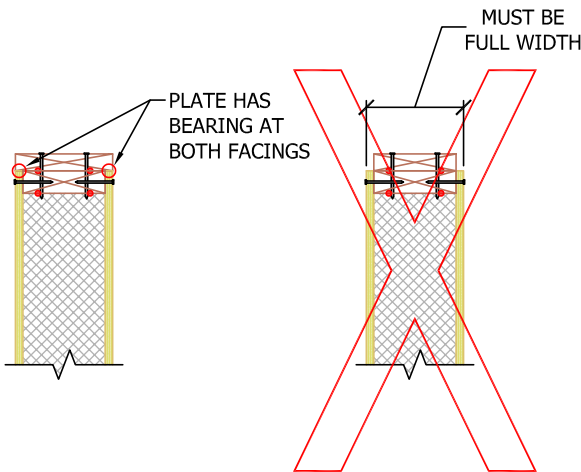

DO NOT HAVE UNSUPPORTED HORIZONTAL JOINTS IN WALL UNLESS SPECIFIC CONDITION IS DESIGNED BY A LICENSED STRUCTURAL ENGINEER. I.E. DON'T STACK WALLS.

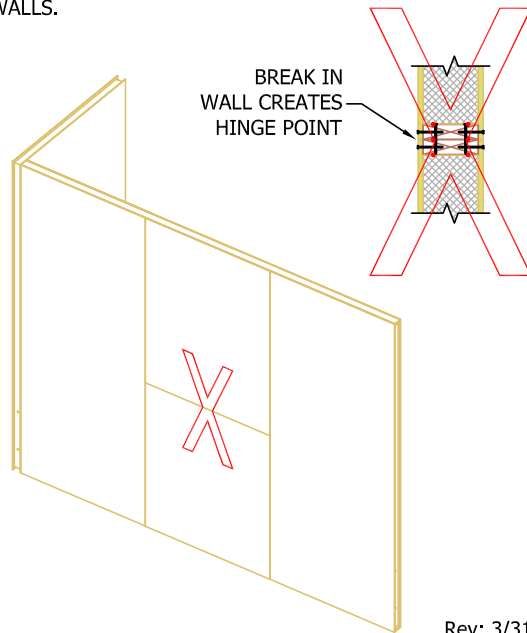

N.T.S.

Rev: 3/31/2022

PBS-101A

SIP BEST PRACTICES EXAMPLES



SIP BEST PRACTICES:

1. HANDLE SIPS WITH APPROPRIATE CARE. PROTECT SIP CORNERS AND AVOID LIFTING SIPS BY EDGE OF TOP FACING.
2. STORE SIPS AND ACCESSORIES A MINIMUM OF 3 INCHES ABOVE GROUND/SURFACE. SUPPORT SIPS FLAT ON MINIMUM OF 3" WIDE STICKERS WITH LENGTH EQUAL TO THE WIDTH OF THE SIPS WITH STICKERS PLACED NO FURTHER THAN FOUR FEET ON CENTER, OR EQUIVALENT.
3. PROTECT SIPS AND ACCESSORIES FROM WEATHER WITH BREATHABLE OPAQUE, WHITE, OR LIGHT-COLORED COVERINGS. IMPORTANT! DO NOT USE CLEAR OR COLORED PLASTIC FILMS TO COVER SIPS. KEEP SIPS COVERED TO AVOID EXPOSURE TO WEATHER FOR AN EXTENDED PERIOD OF TIME. EXPOSURE TO MOISTURE CAN CAUSE WOOD PRODUCTS TO SWELL MAKING INSTALLATION MORE DIFFICULT. PROTECT SIPS FROM WEATHER AS SOON AS PRACTICAL AFTER INSTALLATION.
4. INSTALL FASTENERS FLUSH TO SIP FACING SURFACE. BE SURE NOT TO OVERDRIVE SCREW HEADS INTO SIP FACINGS.
5. IF FIELD CUTTING OPENINGS BE SURE THAT THE EDGE OF THE OPENING CUTS STOP AT A COMMON CORNER. CONTINUATION OF THE CUT PAST THE CORNER SIGNIFICANTLY DECREASES THE STRUCTURAL CAPACITY OF THE SIP.
6. PROVIDE LEVEL AND SQUARE FOUNDATIONS AND/OR SUPPORTING FLOORS. REMOVE DEBRIS FROM SILL PLATE BEFORE SIP INSTALLATION.
7. INSTALL SIPS IN ACCORDANCE WITH APPROVED DRAWINGS. DOUBLE CHECK SIP SIZES AND ELECTRICAL CHASE ORIENTATION WITH SIP SHOP DRAWINGS BEFORE INSTALLATION.
8. DETAILS SPECIFYING SIP TAPE AND SEALANT APPLICATION MUST BE FOLLOWED.
9. PROVIDE ADEQUATE BRACING OF SIPS DURING INSTALLATION.
10. FOLLOW PROPER NAILING REQUIREMENTS ACCORDING TO DETAILS AND JOB SPECIFIC ENGINEERING. BE SURE TO ADJUST YOUR NAIL GUN SO THAT NAIL HEAD IS FLUSH TO SIP FACINGS.
11. USE FACTORY PROVIDED ELECTRICAL CHASES IN SIP CORE OR SURFACE MOUNT CONDUIT. FACINGS SHOULD NOT BE CUT HORIZONTALLY OR VERTICALLY IF ADDITIONAL CHASES ARE REQUIRED. CONSULT YOUR SIPS REPRESENTATIVE TO DISCUSS OPTIONS.
12. MAKE SURE TO PRE-DRILL TOP AND BOTTOM PLATES FOR THE VERTICAL ELECTRICAL CHASES IN THE WALL SIPS. PRE-DRILL DRILL VERTICAL MEMBERS AT HORIZONTAL CHASE LOCATIONS.
13. SIPS CAN BE HEAVY. LIFT AND PLACE SIPS WITH APPROPRIATE EQUIPMENT.
14. WHEN USING 2X, ENGINEERED WOOD, OR I-JOIST SPLINES, USE ONLY CONTINUOUS MEMBERS; STRUCTURAL SPLINES MUST BE CONTINUOUS BETWEEN SUPPORTS.
15. PROVIDE APPROPRIATE BEARING FOR ROOF SIPS PER DETAILS.
16. BEFORE COVERING ROOF SYSTEM MAKE CERTAIN THAT OSB MOISTURE CONTENT OF TOP + BOTTOM FACINGS, AND SPLINE MATERIAL DOESN'T EXCEED APA MAXIMUM MOISTURE CONTENT RECOMMENDATIONS.
17. MAKE SURE SIPS ARE CLEAN AND DRY BEFORE APPLYING INTERIOR OR EXTERIOR MATERIALS.
18. ALL SIP ROOF PENETRATIONS SHOULD BE REVIEWED BY A LICENSED STRUCTURAL ENGINEER.
19. USE CODE RECOGNIZED FLASHINGS AND EXTERIOR WALL AND ROOF COVERINGS.
20. USE CODE RECOGNIZED THERMAL BARRIERS ON INTERIOR PER BUILDING CODES.
21. PLUMBING SHOULD NOT BE INSTALLED WITHIN SIPS; SEE PBS-112 AND PBS-111 FOR ALTERNATIVES.
22. FILL ALL VOIDS WITH LOW EXPANDING FOAM COMPATIBLE WITH EPS.
23. SIP STRUCTURES SHOULD BE REVIEWED BY A LICENSED STRUCTURAL ENGINEER. SIP SUPPLIER IS NOT RESPONSIBLE FOR ERRORS IN DESIGN OR ENGINEERING.
24. ENGINEERED DETAILS TAKE PRECEDENCE OVER GENERIC DETAILS.
25. PROJECT MUST MEET LOCAL CODE.
26. FIELD MODIFICATIONS TO SIPS, SUCH AS OPENINGS AND PENETRATIONS, SHOULD BE REVIEWED BY A LICENSED

N.T.S. STRUCTURAL ENGINEER.

Rev: 9/19/2022

PBS-101B

SIP BEST PRACTICES NOTES



NOTES:

1. SIPS ARE AVAILABLE IN THICKNESSES FROM 4-1/2" THROUGH 12-1/4".
2. SIPS ARE SIZED TO USE STANDARD 2X LUMBER PLATING DIMENSIONS + 1/8" TO ACCOMMODATE LUMBER MILL VARIATIONS.
3. SIP CORE THICKNESS WILL NEVER CHANGE. STANDARD FACINGS ARE 7/16" OSB ON BOTH SIDES.

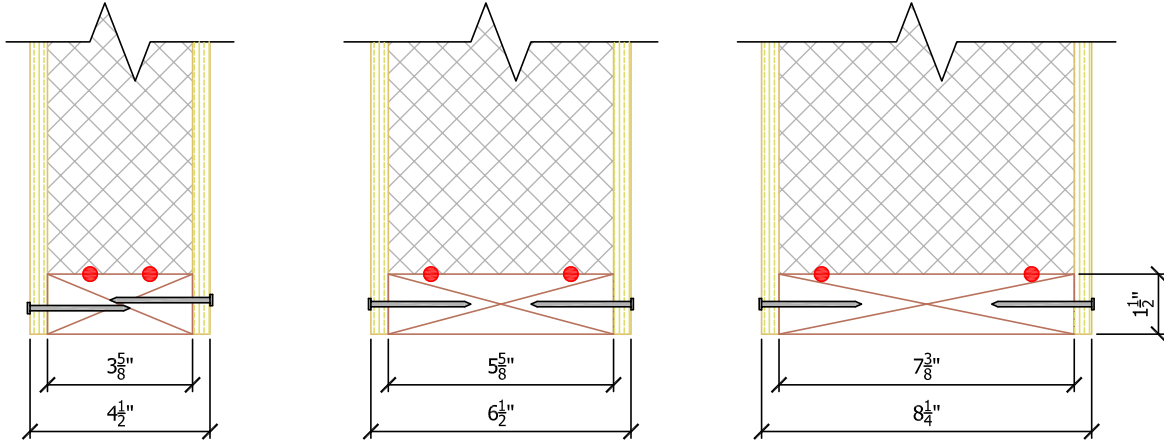

R-VALUE		
	EPS	GPS
75° F	15	18
40° F	16	19
25° F	17	20

R-VALUE		
	EPS	GPS
75° F	23	28
40° F	24	29
25° F	26	30

R-VALUE		
	EPS	GPS
75° F	30	36
40° F	32	37
25° F	33	39

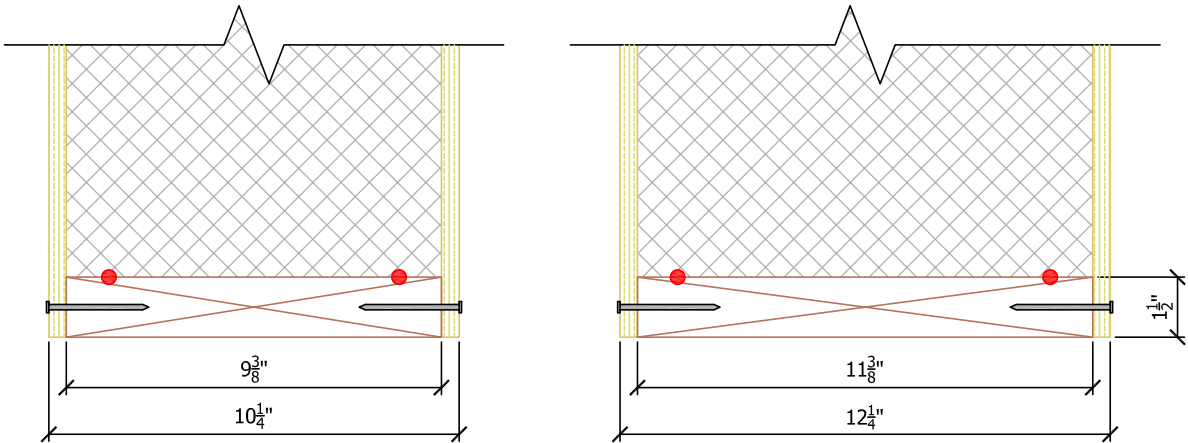

R-VALUE		
	EPS	GPS
75° F	37	45
40° F	40	47
25° F	42	49

R-VALUE		
	EPS	GPS
75° F	45	55
40° F	48	57
25° F	51	59

N.T.S.

* SIP THICKNESSES ARE NOMINAL INCHES

Rev: 6/19/2023

PBS-102

SIP THICKNESS AND R-VALUE



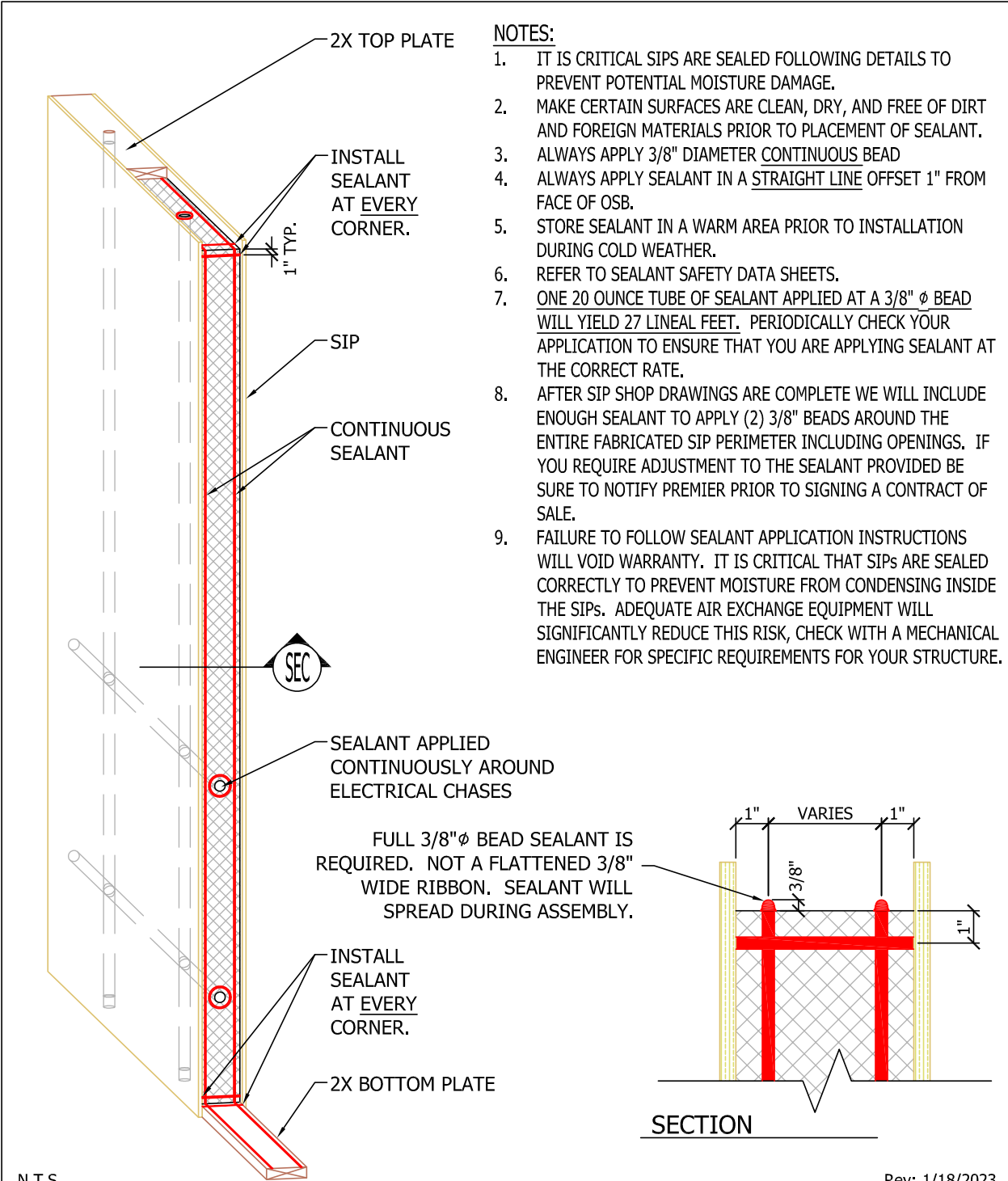

- NOTES:**
1. IT IS CRITICAL SIPs ARE SEALED FOLLOWING DETAILS TO PREVENT POTENTIAL MOISTURE DAMAGE.
 2. MAKE CERTAIN SURFACES ARE CLEAN, DRY, AND FREE OF DIRT AND FOREIGN MATERIALS PRIOR TO PLACEMENT OF SEALANT.
 3. ALWAYS APPLY 3/8" DIAMETER CONTINUOUS BEAD
 4. ALWAYS APPLY SEALANT IN A STRAIGHT LINE OFFSET 1" FROM FACE OF OSB.
 5. STORE SEALANT IN A WARM AREA PRIOR TO INSTALLATION DURING COLD WEATHER.
 6. REFER TO SEALANT SAFETY DATA SHEETS.
 7. ONE 20 OUNCE TUBE OF SEALANT APPLIED AT A 3/8" ϕ BEAD WILL YIELD 27 LINEAL FEET. PERIODICALLY CHECK YOUR APPLICATION TO ENSURE THAT YOU ARE APPLYING SEALANT AT THE CORRECT RATE.
 8. AFTER SIP SHOP DRAWINGS ARE COMPLETE WE WILL INCLUDE ENOUGH SEALANT TO APPLY (2) 3/8" BEADS AROUND THE ENTIRE FABRICATED SIP PERIMETER INCLUDING OPENINGS. IF YOU REQUIRE ADJUSTMENT TO THE SEALANT PROVIDED BE SURE TO NOTIFY PREMIER PRIOR TO SIGNING A CONTRACT OF SALE.
 9. FAILURE TO FOLLOW SEALANT APPLICATION INSTRUCTIONS WILL VOID WARRANTY. IT IS CRITICAL THAT SIPs ARE SEALED CORRECTLY TO PREVENT MOISTURE FROM CONDENSING INSIDE THE SIPs. ADEQUATE AIR EXCHANGE EQUIPMENT WILL SIGNIFICANTLY REDUCE THIS RISK, CHECK WITH A MECHANICAL ENGINEER FOR SPECIFIC REQUIREMENTS FOR YOUR STRUCTURE.

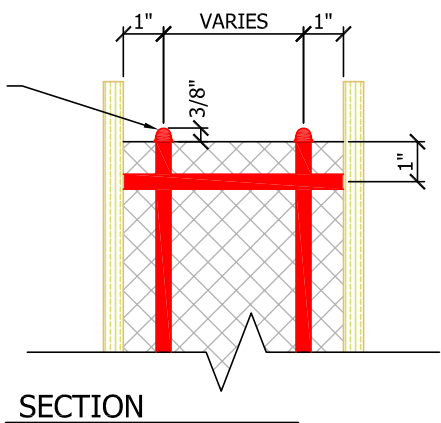

N.T.S.

Rev: 1/18/2023

PBS-103

SIP SEALANT APPLICATION WALLS

PREMIER OSIPS

NOTES:

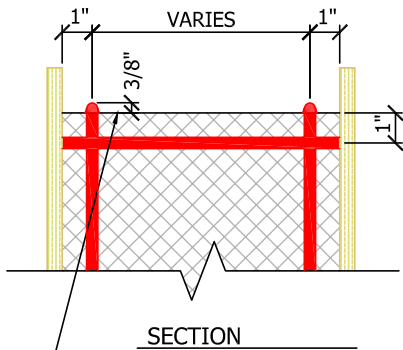

FULL 3/8" ϕ BEAD SEALANT IS REQUIRED. NOT A FLATTENED 3/8" WIDE RIBBON. SEALANT WILL SPREAD DURING ASSEMBLY.

1. IT IS CRITICAL SIPs ARE SEALED FOLLOWING DETAILS TO PREVENT POTENTIAL MOISTURE DAMAGE.
2. MAKE CERTAIN SURFACES ARE CLEAN, DRY, AND FREE OF DIRT AND FOREIGN MATERIALS PRIOR TO PLACEMENT OF SEALANT.
3. ALWAYS APPLY 3/8" DIAMETER CONTINUOUS BEAD.
4. ALWAYS APPLY SEALANT IN A STRAIGHT LINE OFFSET 1" FROM FACE OF OSB.
5. STORE SEALANT IN A WARM AREA PRIOR TO INSTALLATION DURING COLD WEATHER.
6. REFER TO SEALANT SAFETY DATA SHEETS.
7. ONE 20 OUNCE TUBE OF SEALANT APPLIED AT A 3/8" ϕ BEAD WILL YIELD 27 LINEAL FEET. PERIODICALLY CHECK YOUR APPLICATION TO ENSURE THAT YOU ARE APPLYING SEALANT AT THE CORRECT RATE.
8. AFTER SIP SHOP DRAWINGS ARE COMPLETE WE WILL INCLUDE ENOUGH SEALANT TO APPLY (2) 3/8" BEADS AROUND THE ENTIRE FABRICATED SIP PERIMETER INCLUDING OPENINGS. IF YOU REQUIRE ADJUSTMENT TO THE SEALANT PROVIDED BE SURE TO NOTIFY PREMIER PRIOR TO SIGNING A CONTRACT OF SALE.
9. FAILURE TO FOLLOW SEALANT APPLICATION INSTRUCTIONS WILL VOID WARRANTY. IT IS CRITICAL THAT SIPs ARE SEALED CORRECTLY TO PREVENT MOISTURE FROM CONDENSING INSIDE THE SIPs. ADEQUATE AIR EXCHANGE EQUIPMENT WILL SIGNIFICANTLY REDUCE THIS RISK, CHECK WITH A MECHANICAL ENGINEER FOR SPECIFIC REQUIREMENTS FOR YOUR STRUCTURE.

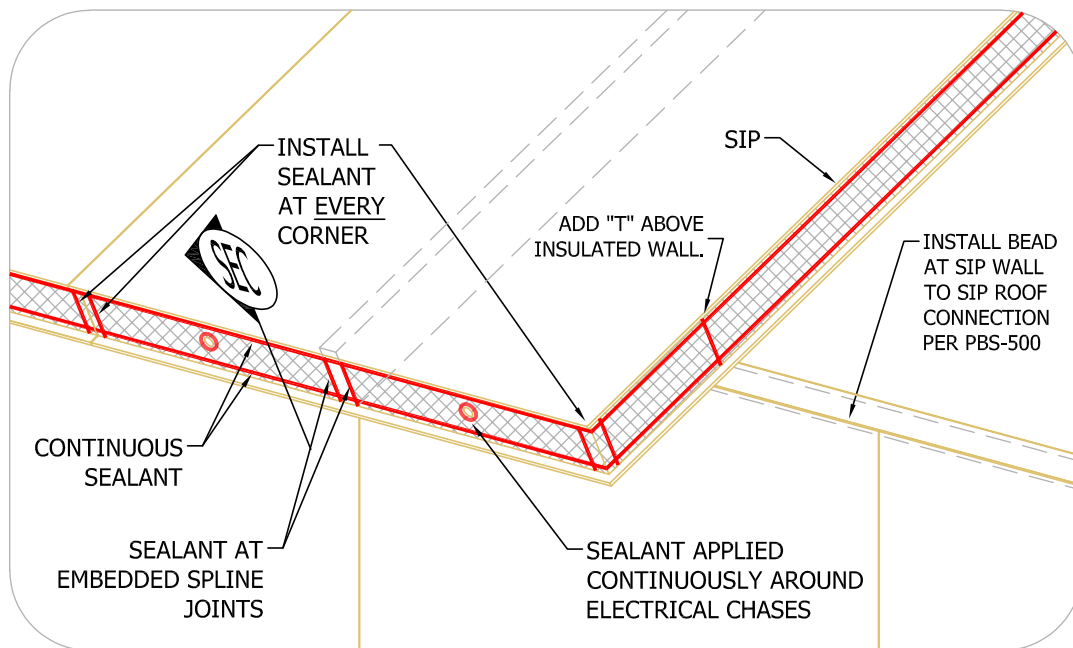

N.T.S.

Rev: 2/15/2023

PBS-104

**SIP SEALANT APPLICATION
ROOF**



NOTES:

SURFACE PREPARATION

ALL SURFACES MUST BE CLEAN, DRY AND FREE OF DUST, DIRT, GREASE, OIL, AND ANY OTHER CONTAMINANTS THAT MAY INTERFERE WITH ADHESION. SURFACE TEMPERATURE OF THE SIP TAPE BEING APPLIED MUST BE 20° F OR WARMER.

TAPE INSTALLATION

POSITION SIP TAPE SO THAT IT IS CENTERED OVER SIP JOINT. WHILE UNROLLING SIP TAPE ALONG CENTER LINE OF SIP JOINT, REMOVE RELEASE FILM AT A 45° ANGLE AND CONTINUE TO PRESS SIP TAPE INTO PLACE. TO ENSURE A TIGHT SEAL AND MINIMIZE AIR BUBBLES AND WRINKLES, SIP TAPE MUST BE PRESSED FIRMLY BY HAND AT THE CENTER, WORKING OUTWARD WITH A SMOOTHING MOTION TO THE EDGES. A ROLLER OR SIMILAR TOOL MUST THEN BE USED TO ROLL OVER THE ENTIRE SIP TAPE SURFACE TO FIRMLY MATE TO SIP SURFACE.

OVERLAPS AND "T" JOINTS

TAPE FOR SIP TO SIP CORNERS AND SIP JOINTS OVER BEAMS SHOULD BE INSTALLED BEFORE IN PLANE SIP JOINTS. OVERLAP TAPE A MINIMUM OF 3" AT "T" JOINTS AND WHEN CONTINUING A SEAM TO INSURE AN AIRTIGHT SEAL.

NOTE: SIP TAPE IS TYPICALLY NOT PROVIDED FOR SIP FLOOR SPLINE OR SIP FLOOR TO SIP WALL CONNECTIONS. HOWEVER, IF GYPCRETE IS TO BE APPLIED TO TOP OF SIP FLOOR WE DO RECOMMEND THE APPLICATION OF 4" SIP TAPE AT ALL JOINTS. PLEASE CONTACT YOUR PBS REPRESENTATIVE TO REQUEST THE ADDITION OF SIP TAPE IF DESIRED.

REFERENCE ACCOMPANYING APPLICATION SEQUENCE DETAIL FOR ADDITIONAL INSTRUCTIONS.

N.T.S.

Rev: 3/31/2022

PBS-105

SIP TAPE APPLICATION NOTES

**PREMIER
OSIPS**



NOTE:

PRIOR TO ANY INTERIOR SIP TAPE APPLICATION, ALL EXTERIOR ROOF AND WALL SURFACES MUST HAVE WEATHER RESISTANT BARRIERS APPLIED TO ROOF AND WALLS. SIP TAPE SHALL BE INSTALLED EITHER INTERIOR OR EXTERIOR BASED ON CODE REQUIREMENTS AND LOCAL CLIMATE CONDITIONS. CONSULT WITH A BUILDING SCIENCE PROFESSIONAL TO DETERMINE THE LOCATION OF SIP TAPE APPLICATION ON YOUR STRUCTURE. REFER TO PBS-105B FOR EXTERIOR APPLICATION.

TAPE APPLICATION SEQUENCE:

1. APPLY TAPE TO JOINTS OVER BEAMS

ROLL OUT TAPE CENTERED OVER BEAM PRIOR TO SIP INSTALLATION AND SECURE TEMPORARILY WITH STAPLES. AFTER SIPS ARE INSTALLED AND SECURED OVER TAPE, REMOVE BACKING, PRESS FIRMLY INTO PLACE, AND FIRMLY ROLL.

2. INSTALL SIPS

IF RAIN IS OCCURRING AT TIME OF SIP ROOF INSTALLATION RUN A BEAD OF SEALANT AT EXTERIOR SIP JOINT TO PREVENT MOISTURE PENETRATION INTO SPLINE JOINT. IF YOU BELIEVE RAIN WILL BE LIKELY DURING INSTALLATION CONTACT YOUR SIP REPRESENTATIVE TO PURCHASE ADDITIONAL SEALANT.

3. APPLY SIP TAPE TO WALLS AND ROOF SIPS

DO NOT APPLY SIP TAPE ON THE UNDERSIDE OF ROOF SIPS PRIOR TO THE INSTALLATION OF ROOFING UNDERLAYMENT AND ROOF COVERING.

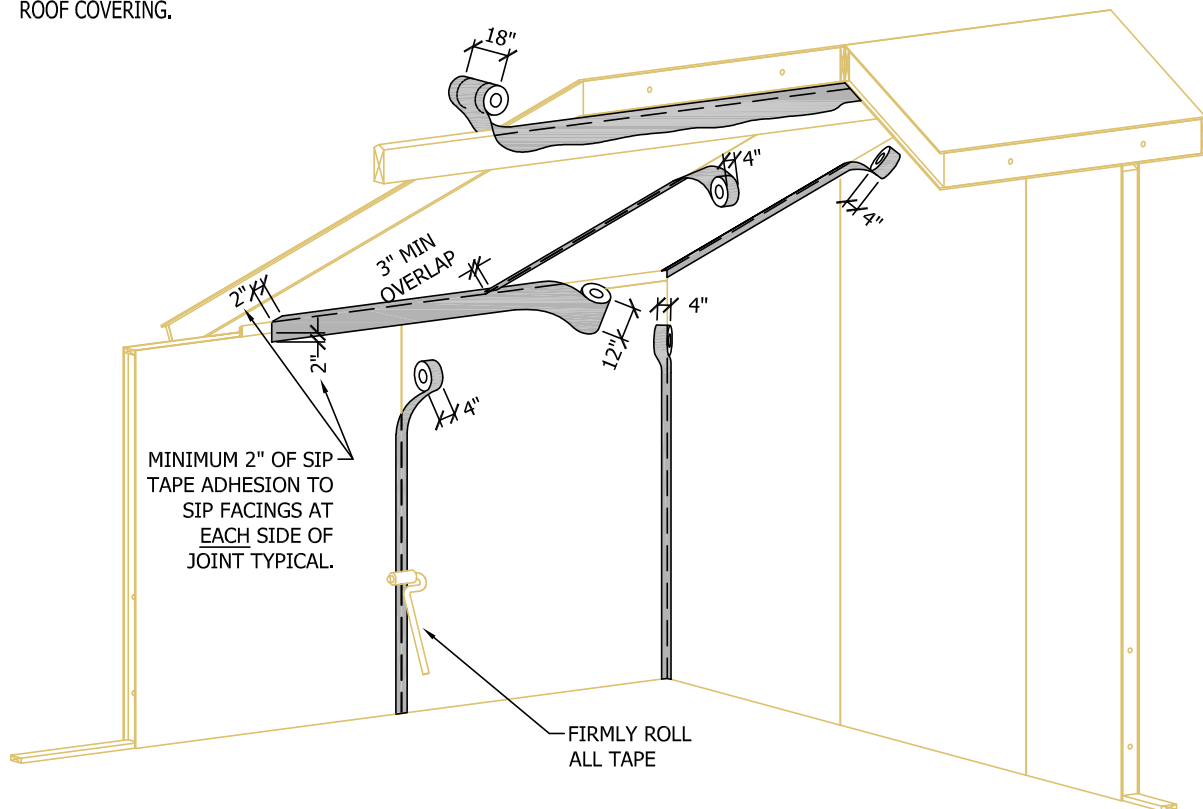

N.T.S.

Rev: 12/10/2021

PBS-105A

SIP TAPE APPLICATION
INTERIOR



NOTE:

SIP TAPE SHALL BE INSTALLED EITHER INTERIOR OR EXTERIOR BASED ON CODE REQUIREMENTS AND LOCAL CLIMATE CONDITIONS. CONSULT WITH A BUILDING SCIENCE PROFESSIONAL TO DETERMINE THE LOCATION OF SIP TAPE APPLICATION ON YOUR STRUCTURE. REFER TO PBS-105A FOR INTERIOR APPLICATION.

TAPE APPLICATION SEQUENCE:

1. INSTALL SIPS

IF RAIN IS OCCURRING AT TIME OF SIP ROOF INSTALLATION RUN A BEAD OF SEALANT AT EXTERIOR SIP JOINT TO PREVENT MOISTURE PENETRATION INTO SPLINE JOINT. IF YOU BELIEVE RAIN WILL BE LIKELY DURING INSTALLATION CONTACT YOUR SIP REPRESENTATIVE TO PURCHASE ADDITIONAL SEALANT.

2. APPLY SIP TAPE TO WALLS AND ROOF SIPS

INSTALL TAPE FROM THE TOP TO THE BOTTOM OF THE SIP JOINTS BEGINNING WITH THE WALL CONNECTIONS, FOLLOWED BY WALL TO ROOF CONNECTIONS, AND THE ROOF JOINT SIP TAPE TO BE APPLIED LAST.

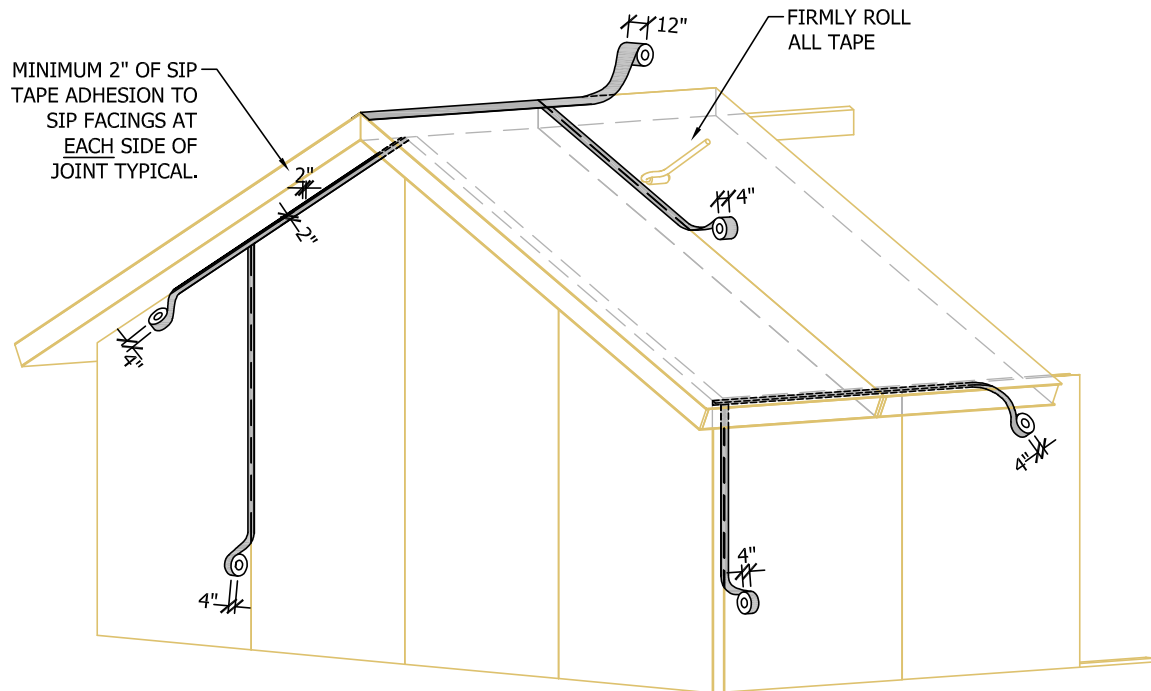

N.T.S.

Rev: 12/10/2021

PBS-105B

**SIP TAPE APPLICATION
EXTERIOR**

**PREMIER
OSIPS**



NOTES:

1. STANDARD HORIZONTAL ELECTRICAL CHASES ARE PROVIDED AT 14" AND 42" FROM BOTTOM OF SIP AND ROUGHLY 48" O.C. VERTICALLY UNLESS PRIOR ARRANGEMENTS HAVE BEEN MADE BEFORE SIP MANUFACTURING.
2. A VERTICAL CHASE 8" FROM EACH SIDE OF DOOR OPENING IS PROVIDED WHERE ALLOWABLE.
3. ADDITIONAL CUSTOMER SPECIFIED ELECTRICAL CHASES MUST BE PRE-ARRANGED WITH SIP SHOP DRAWING APPROVAL.
4. SIP INSTALLER SHALL PROVIDE FIELD DRILLED HOLES IN TOP PLATES, SILL / BASE PLATES, VERTICAL PLATES, AND THROUGH FLOOR TO ACCESS ELECTRICAL CHASES.
5. FOLLOW LOCAL CODE REQUIREMENTS FOR ELECTRICAL INSTALLATION.
6. ALL PENETRATIONS ARE REQUIRED TO BE FOAMED IN PLACE AFTER ELECTRICAL ROUGH IN IS COMPLETE.

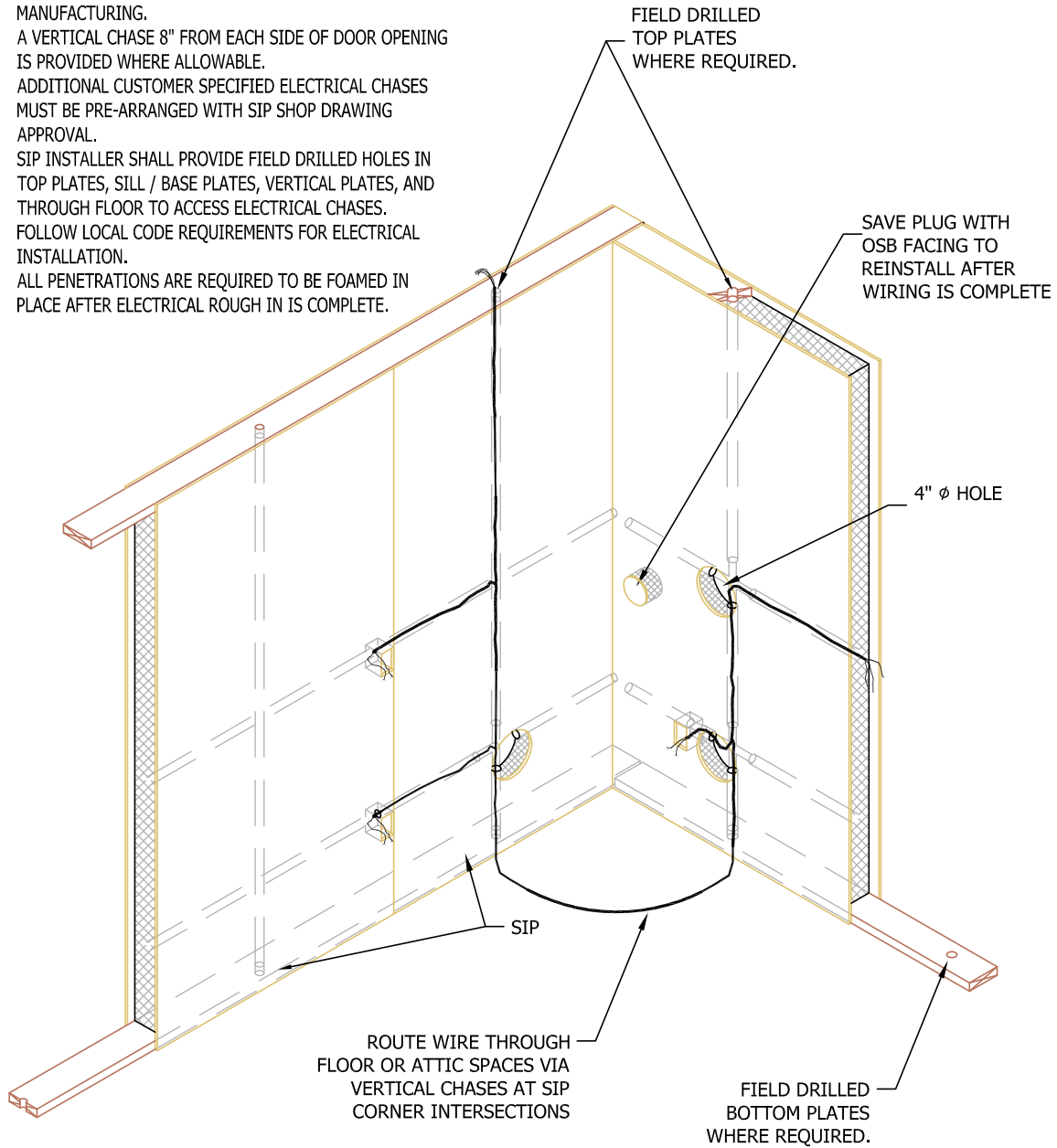

N.T.S.

Rev: 6/19/2023

PBS-106A

**WALL ELECTRICAL CHASES
CORNER ROUTED THROUGH FLOOR**

**PREMIER
SIPS**



NOTES:

1. STANDARD HORIZONTAL ELECTRICAL CHASES ARE PROVIDED AT 14" AND 42" FROM BOTTOM OF SIP AND ROUGHLY 48" O.C. VERTICALLY UNLESS PRIOR ARRANGEMENTS HAVE BEEN MADE BEFORE SIP MANUFACTURING.
2. A VERTICAL CHASE 8" FROM EACH SIDE OF DOOR OPENING IS PROVIDED WHERE ALLOWABLE.
3. ADDITIONAL CUSTOMER SPECIFIED ELECTRICAL CHASES MUST BE PRE-ARRANGED WITH SIP SHOP DRAWING APPROVAL.
4. SIP INSTALLER SHALL PROVIDE FIELD DRILLED HOLES IN TOP PLATES, SILL / BASE PLATES, VERTICAL PLATES, AND THROUGH FLOOR TO ACCESS ELECTRICAL CHASES.
5. FOLLOW LOCAL CODE REQUIREMENTS FOR ELECTRICAL INSTALLATION.
6. ALL PENETRATIONS ARE REQUIRED TO BE FOAMED IN PLACE AFTER ELECTRICAL ROUGH IN IS COMPLETE.

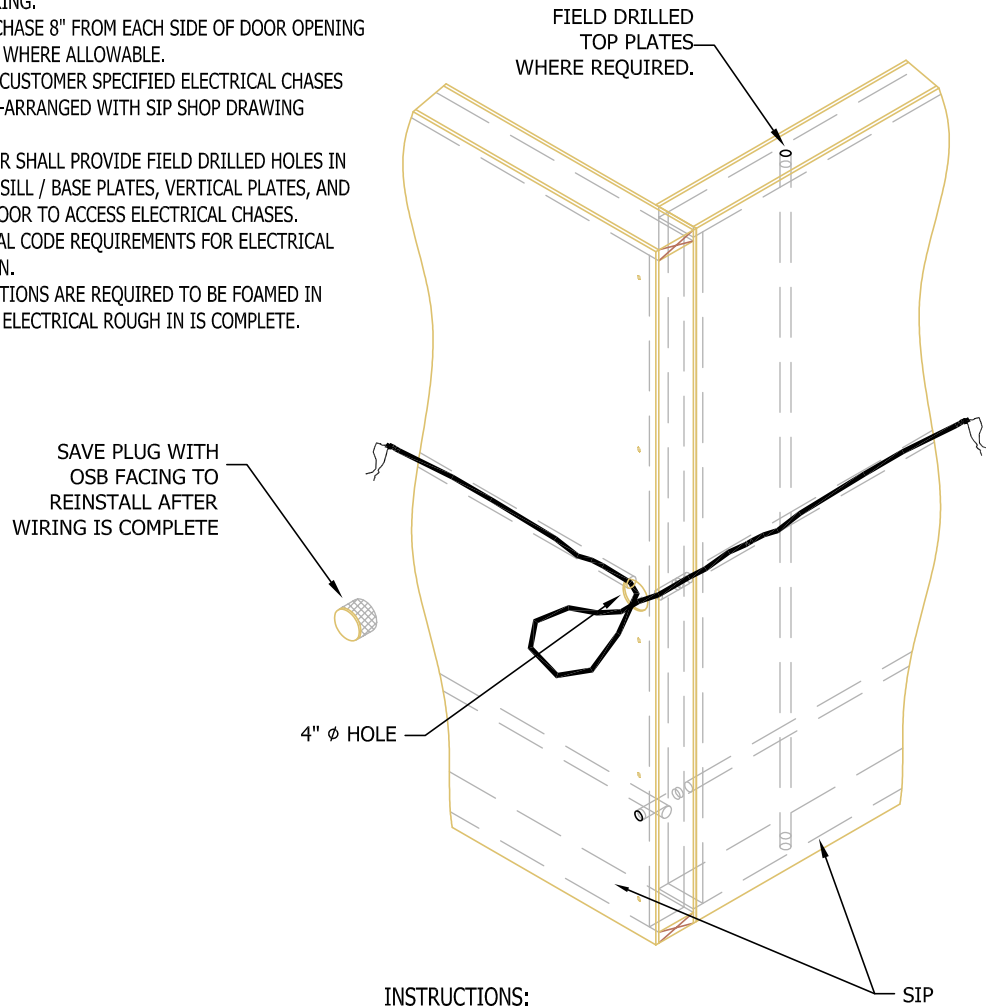

INSTRUCTIONS:

1. CUT HOLE IN CORNER WITH HOLE SAW TO ACCESS CHASES AT INTERSECTION.
2. PUSH WIRE TO CORNER HOLE.
3. PULL THE REQUIRED AMOUNT OF WIRE THROUGH THE CREATED CORNER HOLE.
4. PUSH THE WIRE THROUGH ADJACENT HOLE TO NEXT NEEDED INTERSECTION OR BOX.

N.T.S.

Rev: 6/19/2023

PBS-106B

WALL ELECTRICAL CHASES
CORNER ROUTED THROUGH EXTERIOR

PREMIER
OSIPS



NOTES:

1. ON REQUEST, PREMIER OFFERS STANDARD ROOF ELECTRICAL CHASES OFFSET 2' AND 6' RUNNING PARALLEL TO ONE OF THE LONG EDGES OF SIP ROOF.
2. ADDITIONAL CUSTOMER SPECIFIED ELECTRICAL CHASES MUST BE PRE-ARRANGED WITH SIP SHOP DRAWING APPROVAL.
3. SIP INSTALLER SHALL PROVIDE FIELD DRILLED HOLES IN PANEL SPLINES FOR ELECTRICAL CHASE ACCESS.
4. FOLLOW LOCAL CODE REQUIREMENTS FOR ELECTRICAL INSTALLATION.
5. ALL PENETRATIONS ARE REQUIRED TO BE FOAMED IN PLACE AFTER ELECTRICAL ROUGH IN IS COMPLETE.

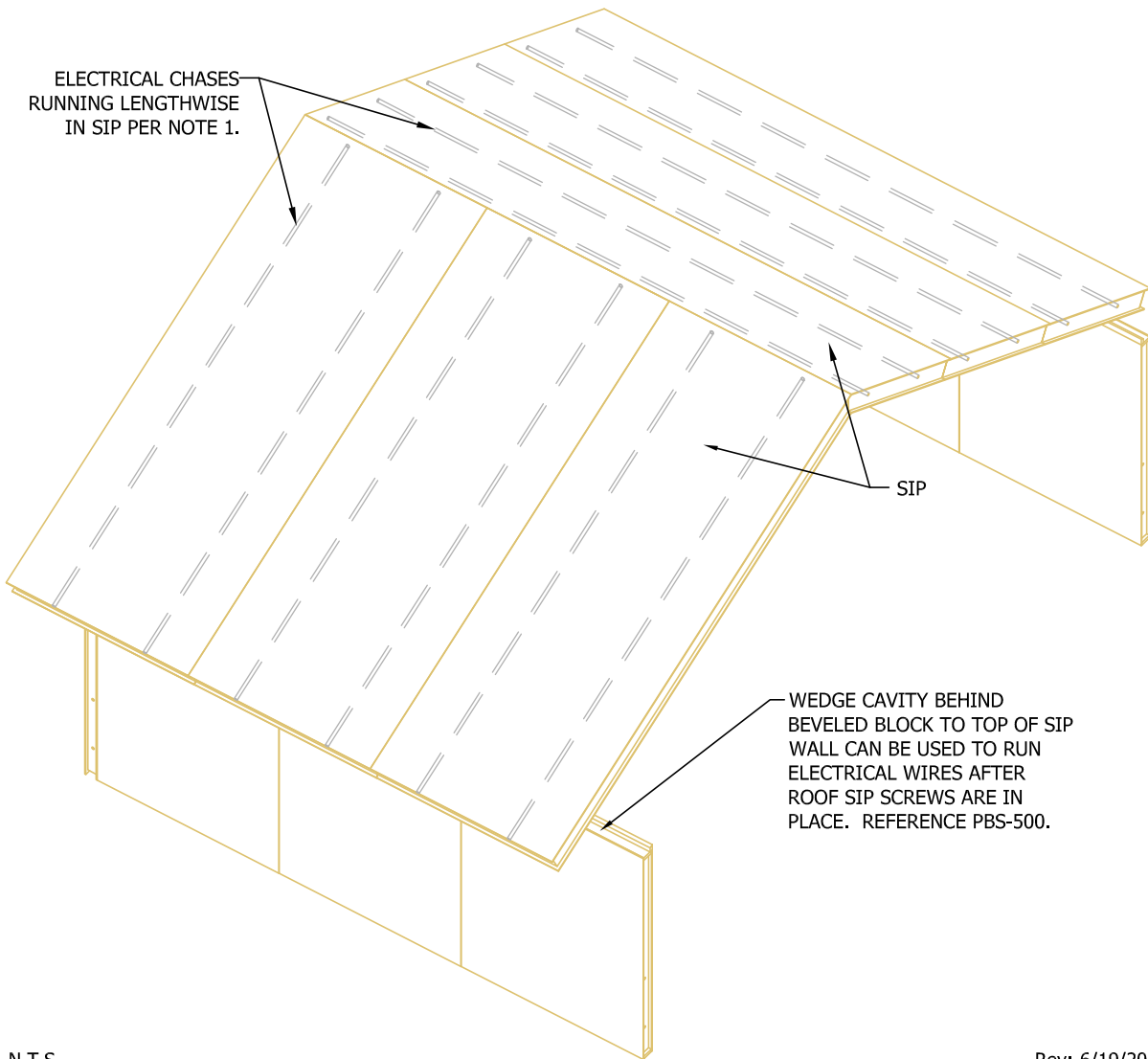

N.T.S.

Rev: 6/19/2023

PBS-107

ROOF ELECTRICAL CHASES

**PREMIER
OSIPS**



NOTES:

1. USE OF LOW EXPANDING FOAM AFTER ELECTRICAL INSTALLATION IS CRITICAL FOR AIR SEALING

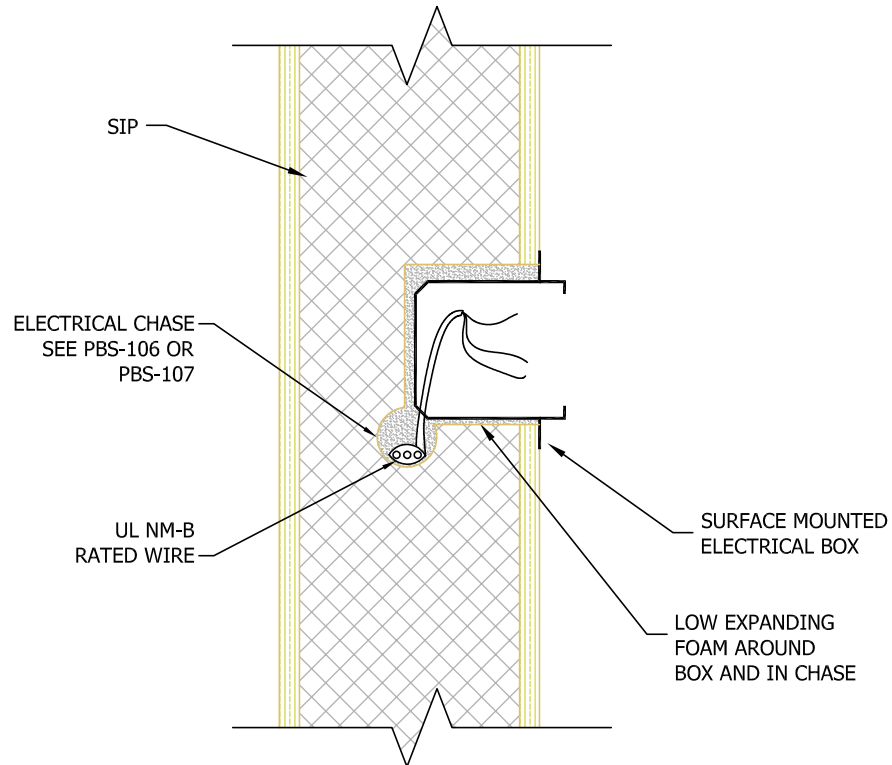

N.T.S.

Rev: 12/10/2021

PBS-108

ELECTRICAL BOXES

**PREMIER
OSIPS**



NOTES:

1. USE IN CONJUNCTION WITH PBS-400

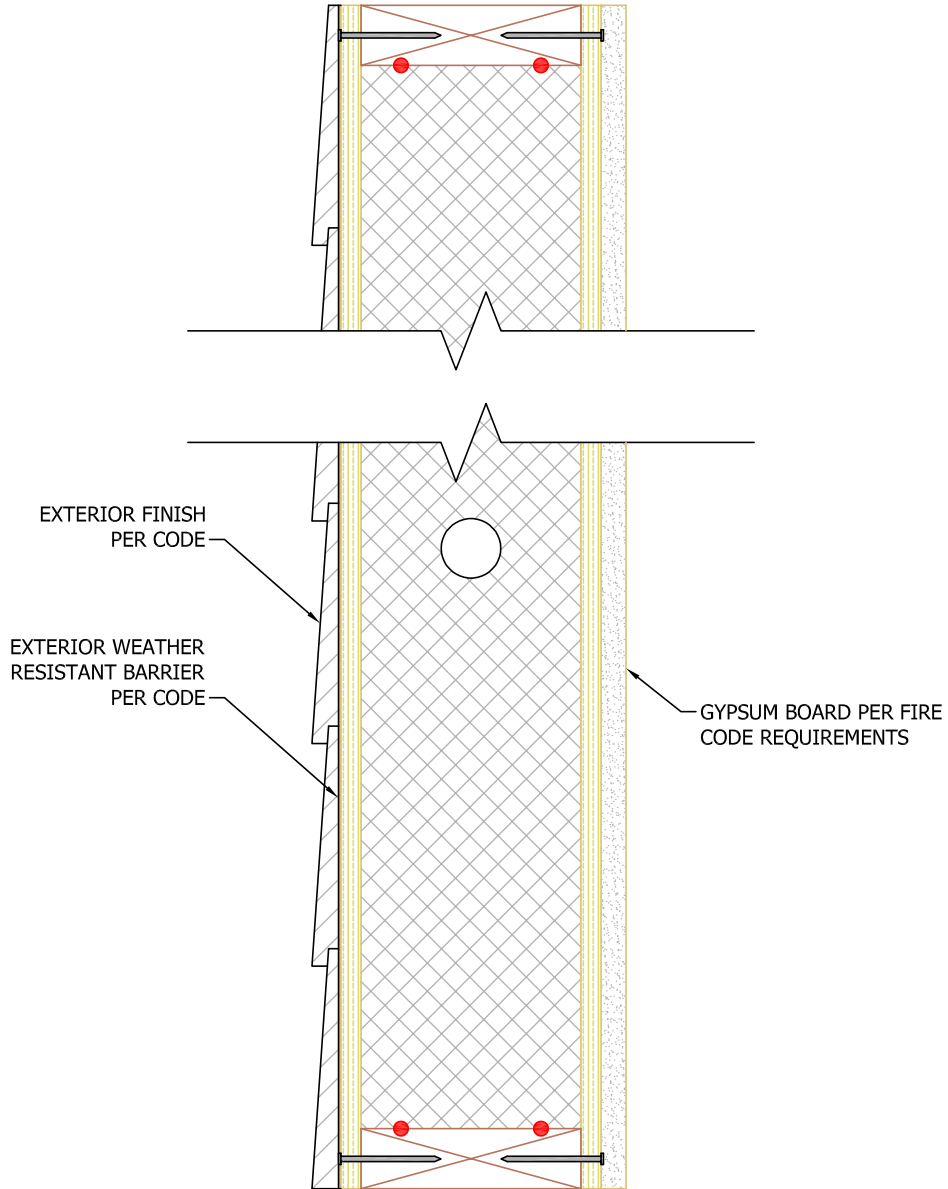

N.T.S.

Rev: 12/10/2021

PBS-109

SIP WALL FINISHES



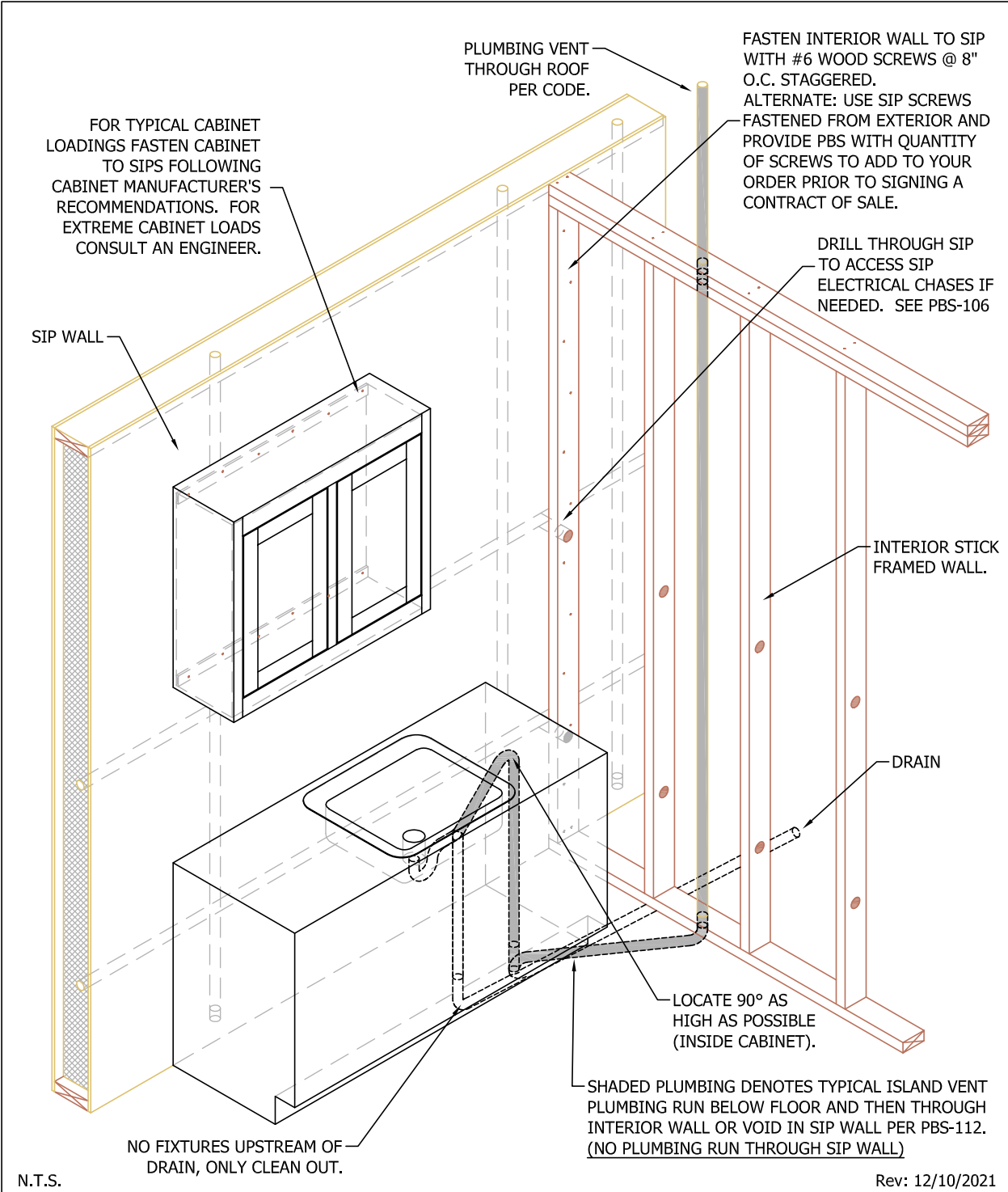

PBS-110

SIP WALL INTERIOR DETAILS

PREMIER SIPS

NOTE:

FASTENER / ADHESIVE ATTACHMENT OF 2X'S AND SPRINKLER SYSTEM TO BE SPECIFIED BY AN ENGINEER.

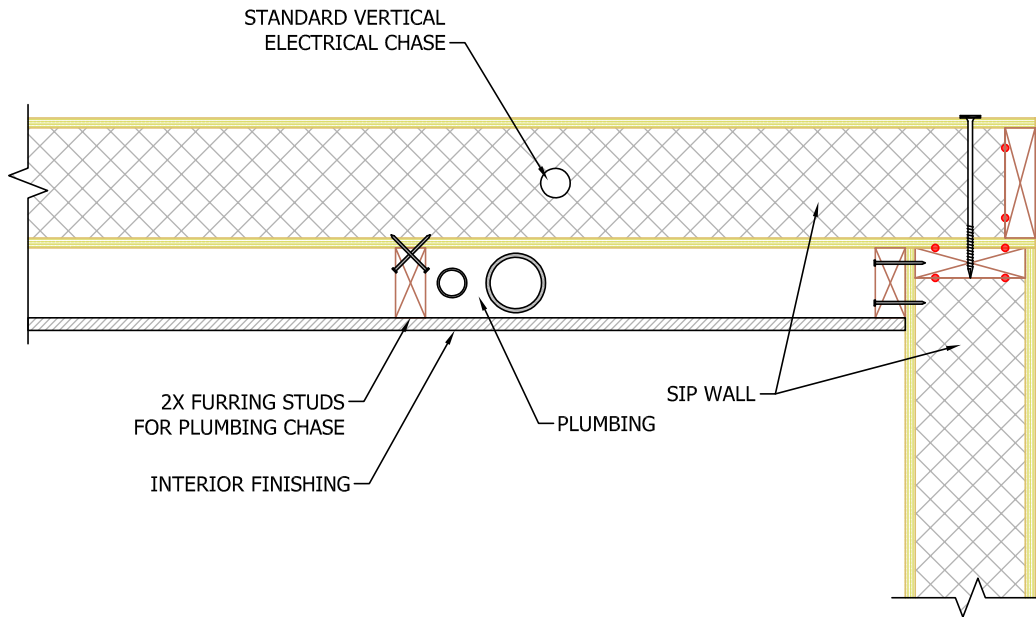
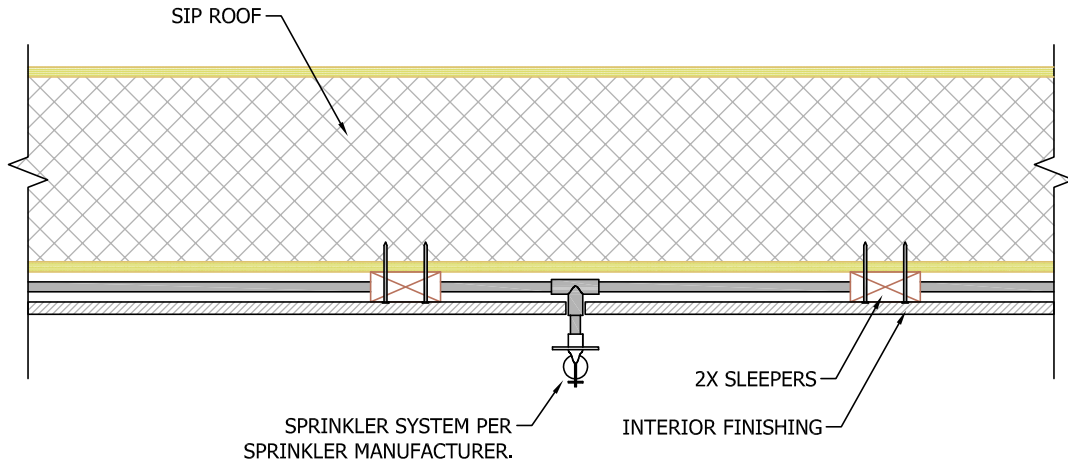

N.T.S.

Rev: 6/7/2023

PBS-111

SIP FURRING



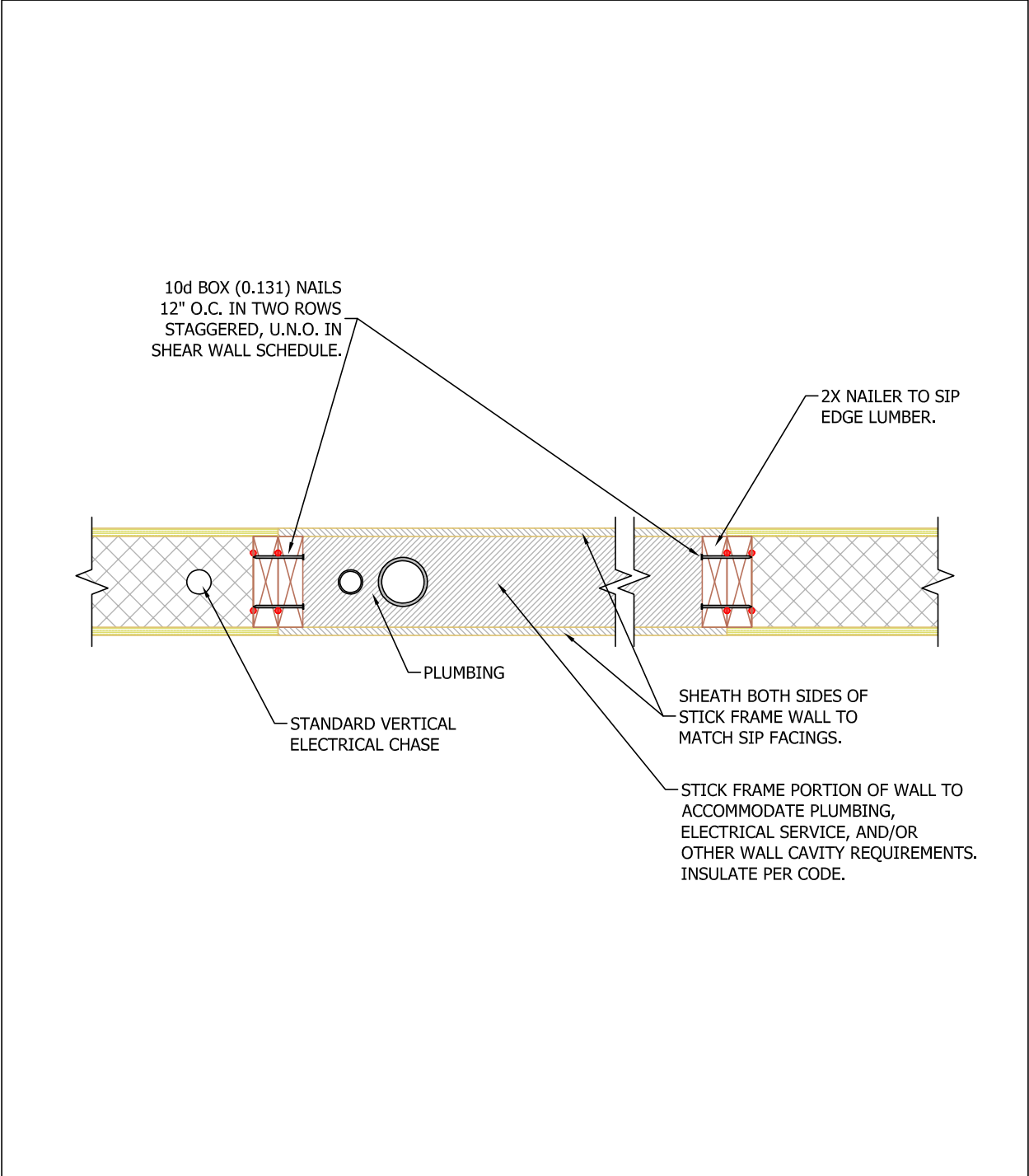

N.T.S.

Rev: 6/7/2023

PBS-112

VOID IN SIP WALL



NOTES:

1. SIP TAPE MAY BE IMPOSSIBLE TO APPLY IN TIMBER FRAME APPLICATIONS. CONSULT A BUILDING DESIGN PROFESSIONAL FOR SPECIFICATION OF AN ALTERNATE VAPOR BARRIER.
2. A SPACER BOARD MATCHING DEPTH OF INTERIOR FINISH MAY BE USED BETWEEN TIMBER FRAME AND SIP SO THAT FINISH CAN BE TUCKED IN BETWEEN FRAME AND SIP FACING.

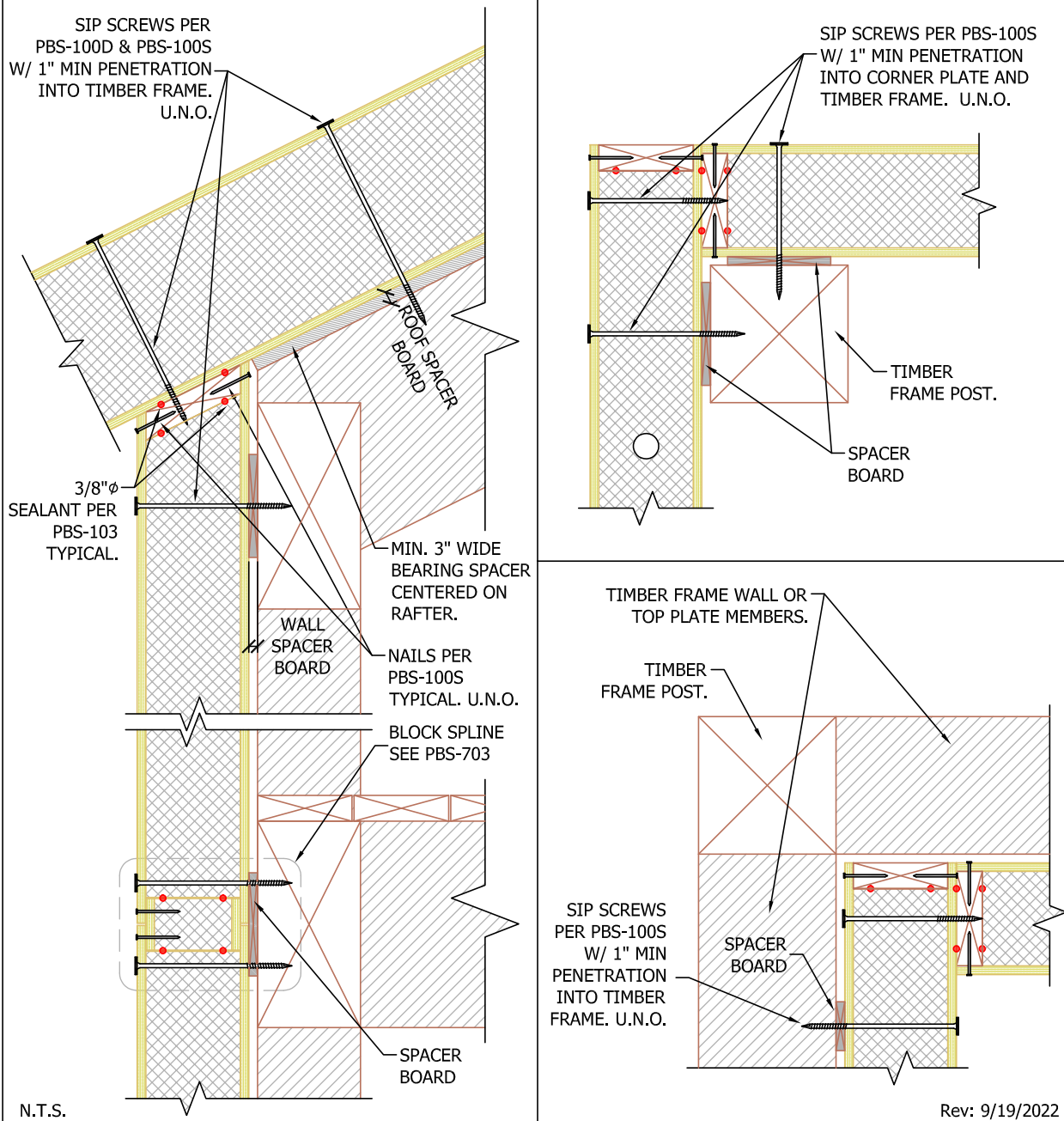

Rev: 9/19/2022

PBS-113

SIP TO TIMBER FRAME DETAILS



NOTE:

PROTECT SIP CORE FROM TEMPERATURES OF 160°F OR ABOVE. USE ZERO CLEARANCE INSULATING MATERIAL DESIGNED FOR HIGH TEMPS AS REQUIRED.

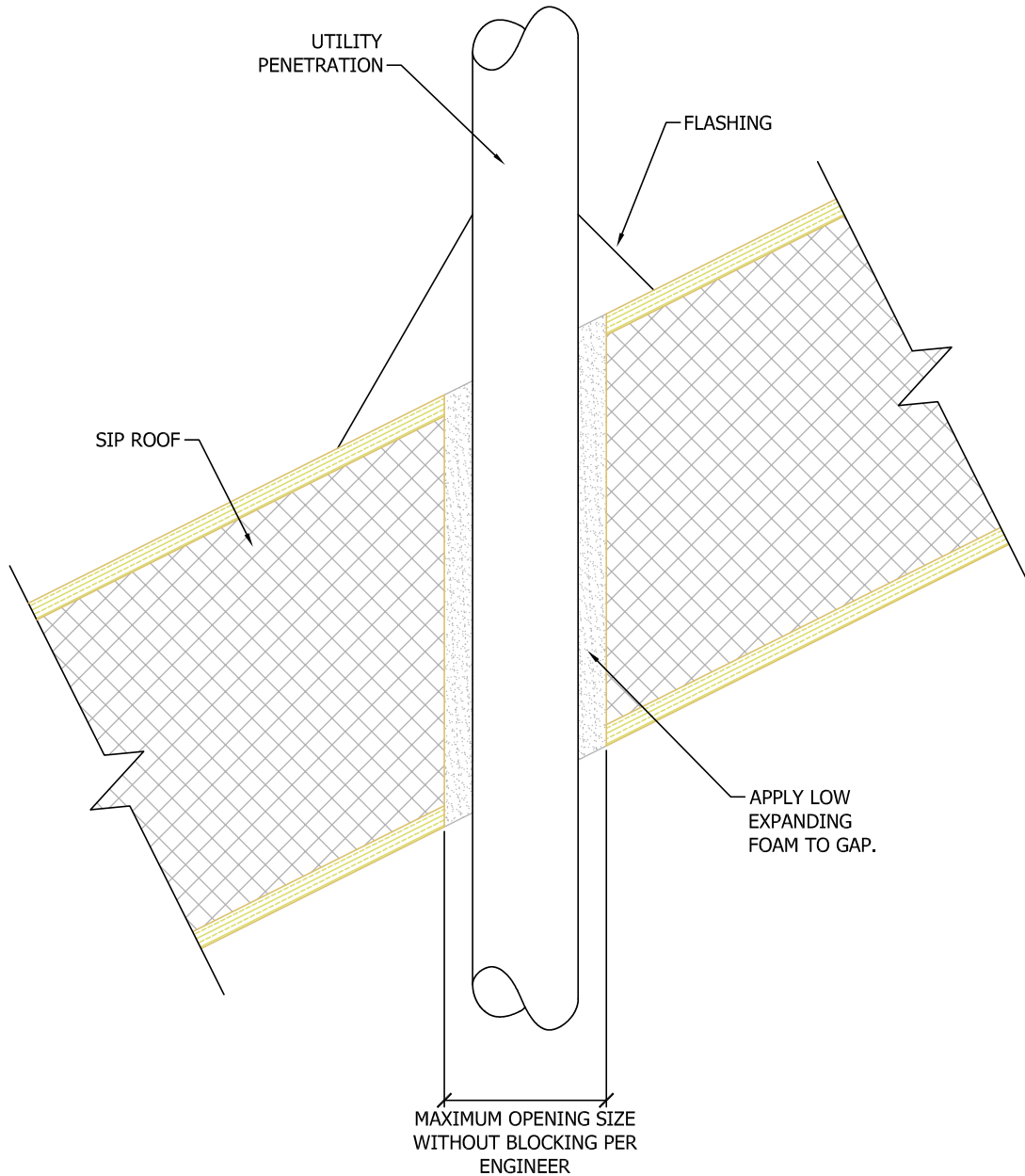

N.T.S.

Rev: 9/19/2022

PBS-114

SIP ROOF PENETRATIONS



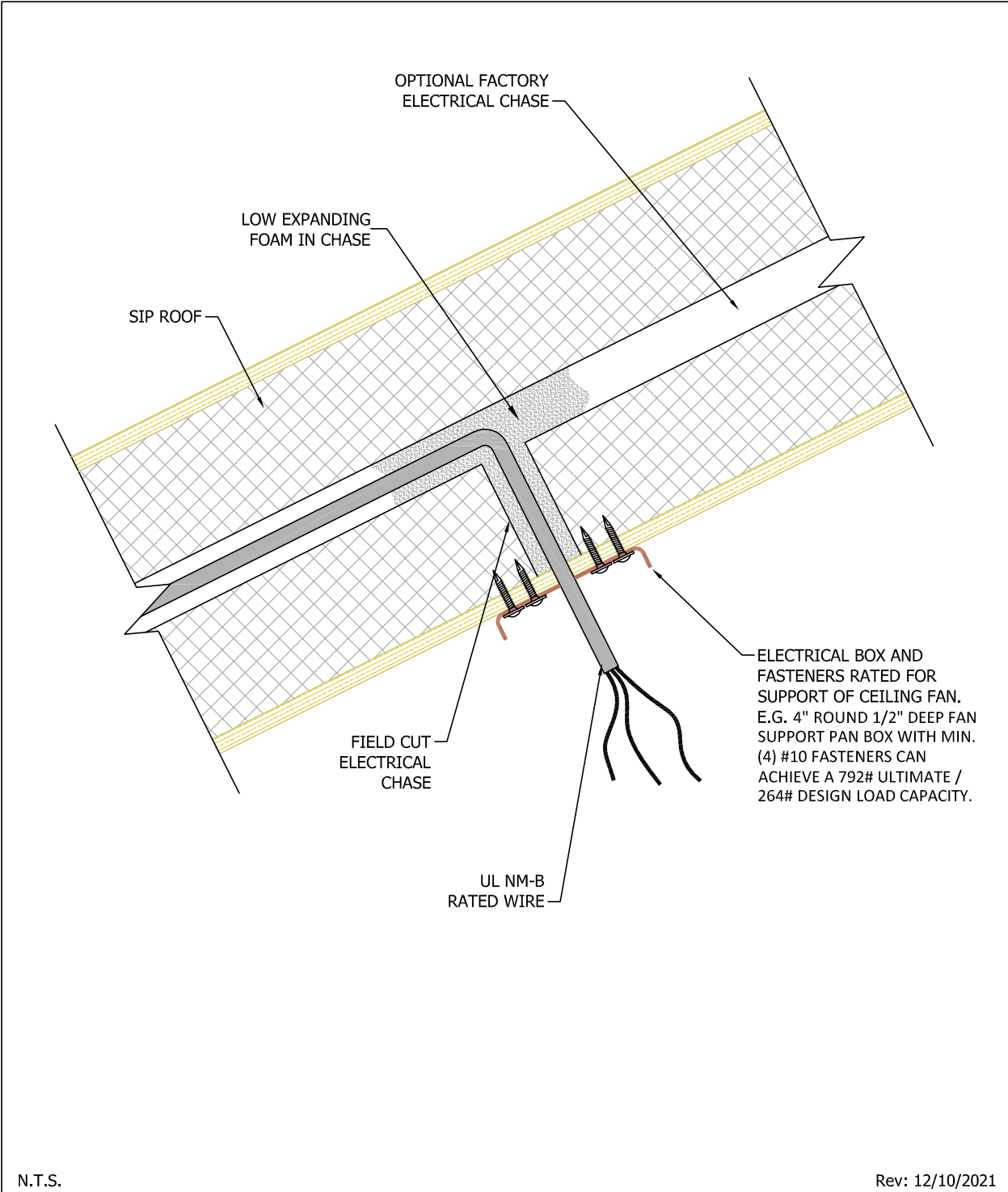

PBS-115

CEILING FAN ATTACHMENT



NOTE:

BLOCK SPLINES ARE NOT REQUIRED TO BE CONTINUOUS ALONG TOTAL LENGTH OF SPLINE CONNECTION. CUT BLOCK SPLINES AS NEEDED TO COMPLETE CONNECTION.

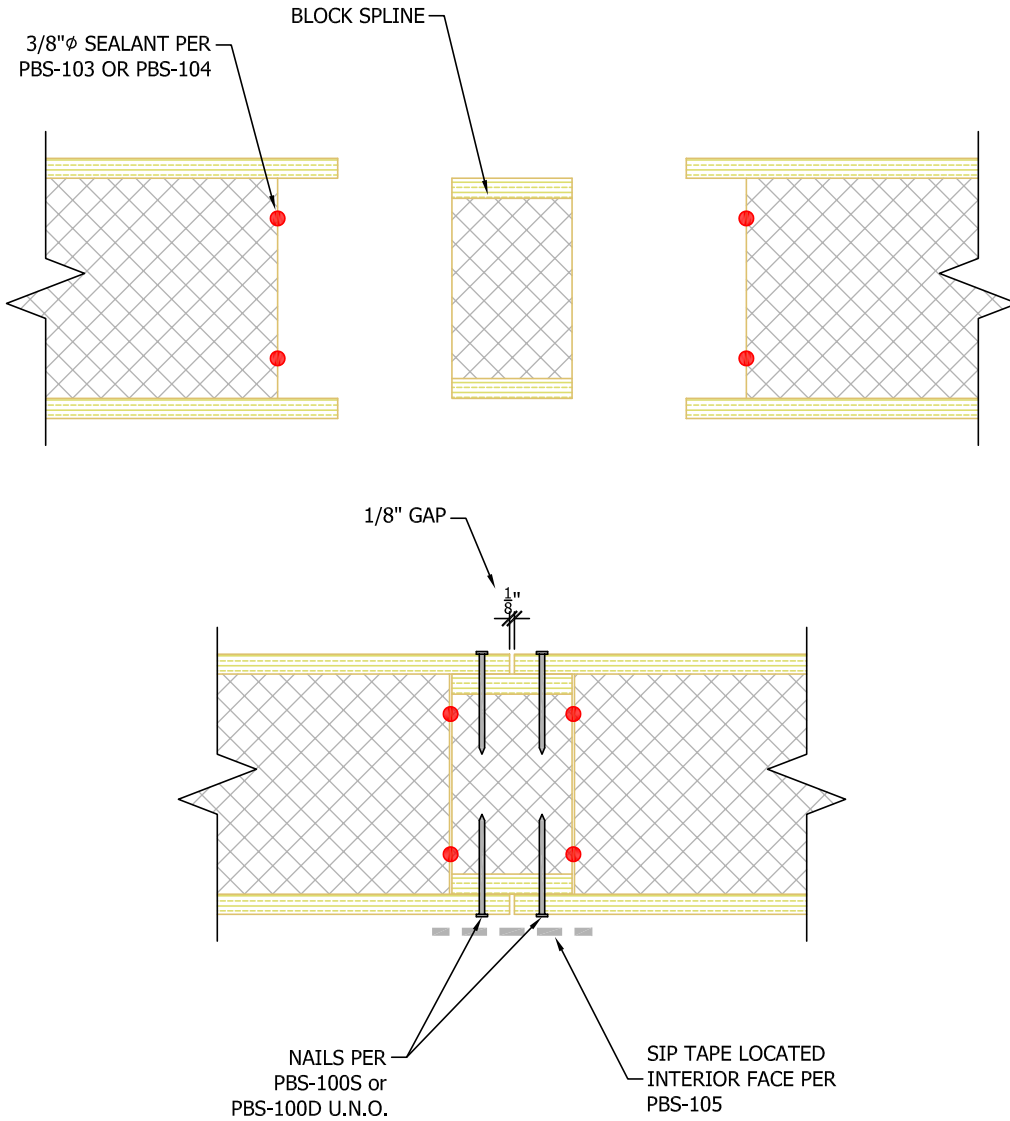

N.T.S.

Rev: 2/16/2023

PBS-200

TYPE S (BOX/BLOCK) SPLINE



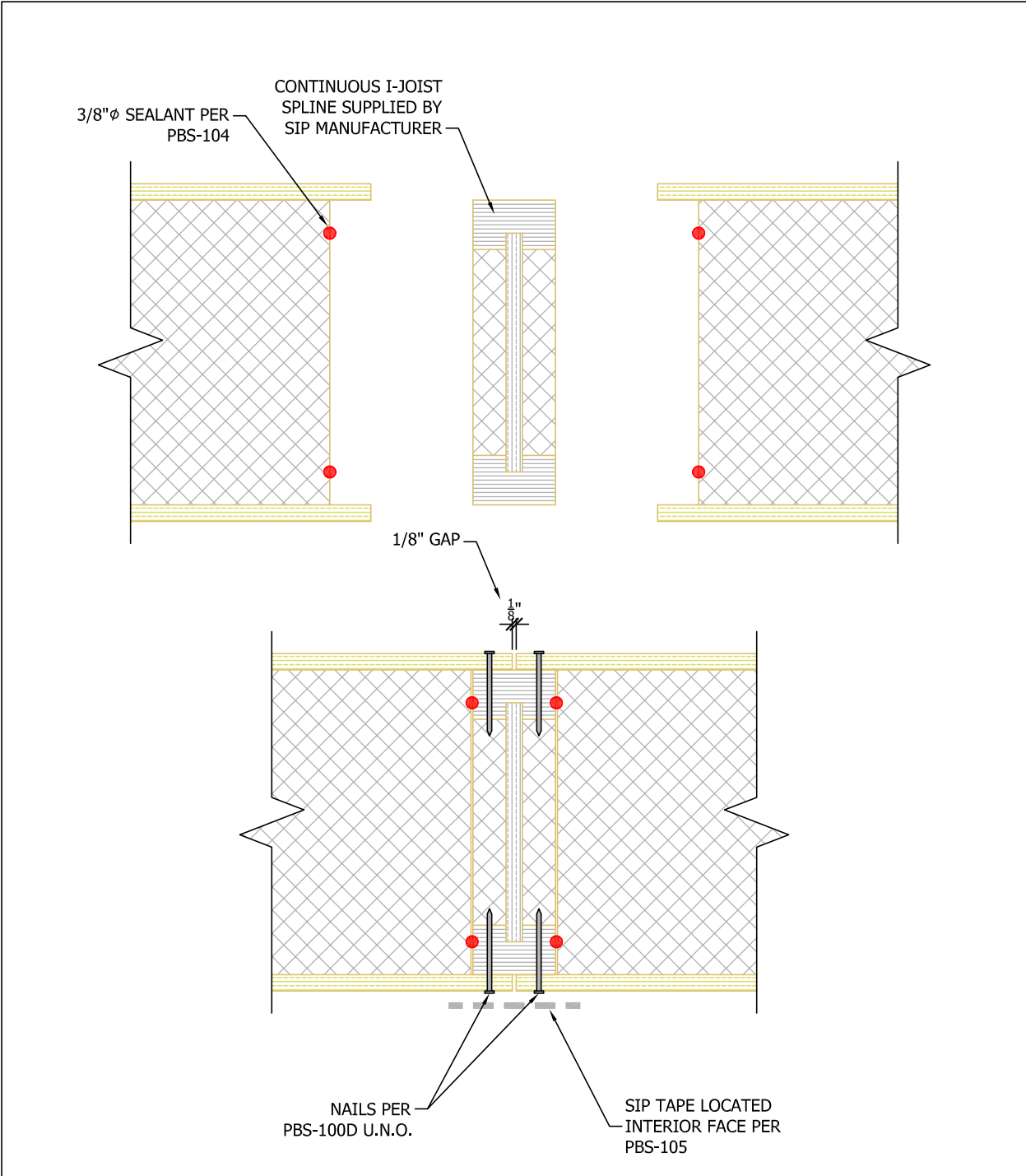

N.T.S.

Rev: 6/20/2023

PBS-201A

TYPE I (I-JOIST) SPLINE



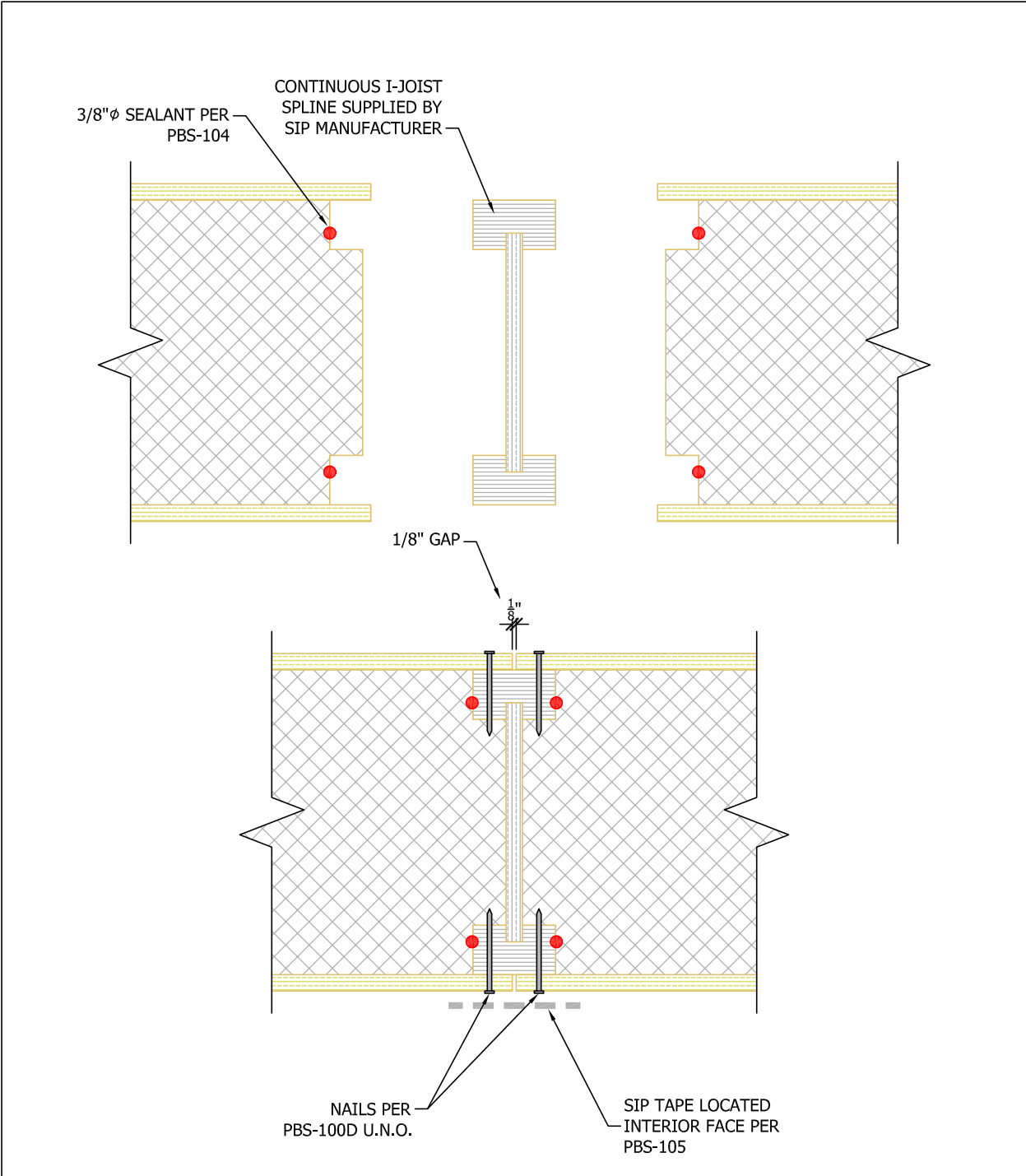

N.T.S.

Rev: 6/20/2023

PBS-201B

TYPE I (I-JOIST) SPLINE
SIP FOAM PROFILED



NOTE:

I-JOISTS WILL BE SECURED WITH SINGLE NAIL IN FACTORY PRIOR TO SHIPMENT. INSTALLER IS RESPONSIBLE FOR NAILING OFF EMBEDDED I-JOIST PER PLAN IN THE FIELD PRIOR TO SIP PLACEMENT TO PREVENT SPLINE FROM SLIDING OUT OF SIP DURING LIFT.

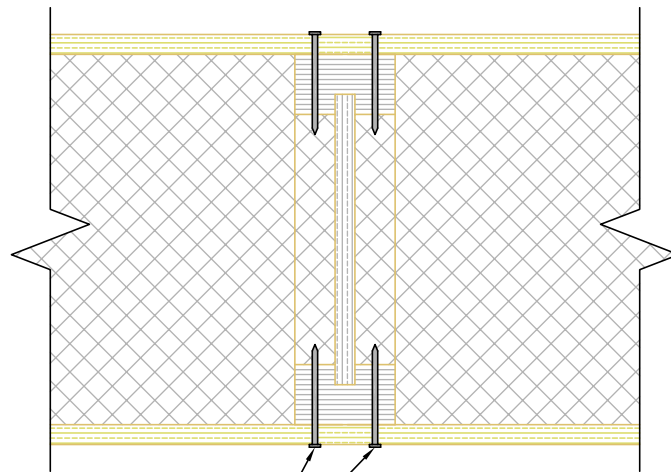

NAILS PER
PBS-100D U.N.O.

N.T.S.

Rev: 12/10/2021

PBS-202

EMBEDDED I (I-JOIST) SPLINE



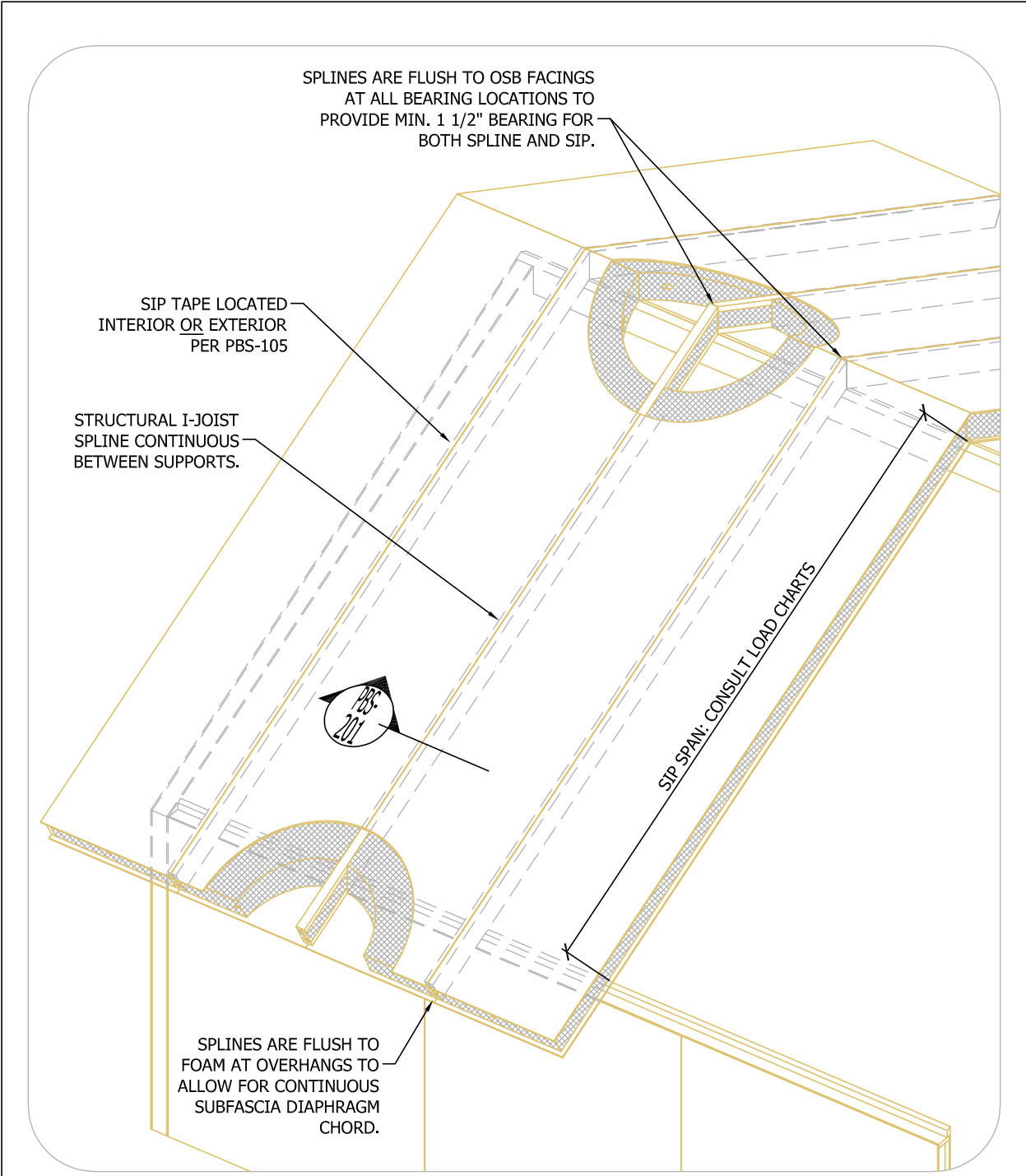

N.T.S.

Rev: 7/19/2022

PBS-203

I-JOIST SIP CONNECTION



3/8" ϕ SEALANT AT EACH MEMBER PER PBS-103 OR PBS-104

CONTINUOUS DOUBLE 2X SPLINE.

10d BOX (0.131) NAILS 12" O.C. IN TWO ROWS STAGGERED FOR EACH MEMBER, U.N.O. IN SHEAR WALL SCHEDULE

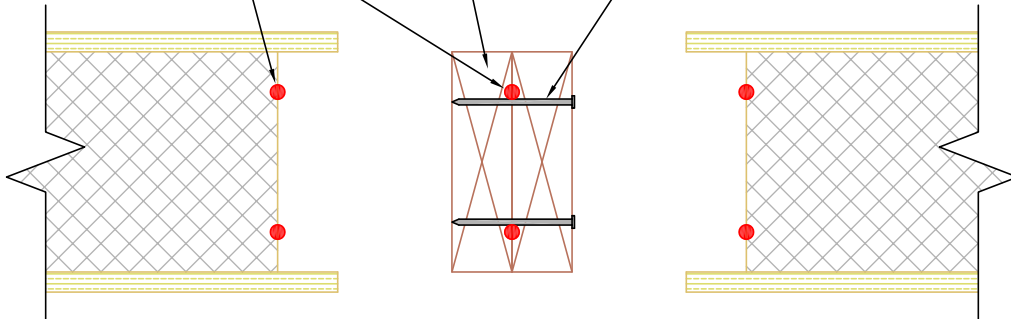

1/8" GAP

1"

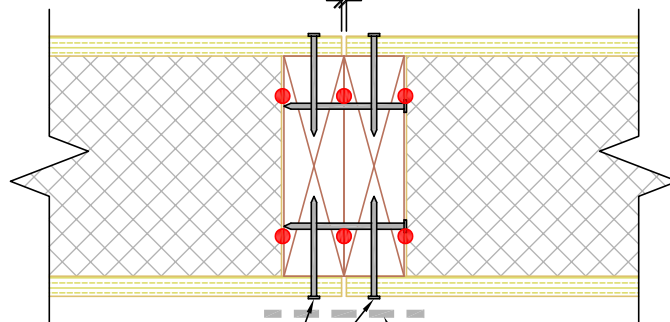

NAILS INTO EACH MEMBER PER PBS-100S or PBS-100D U.N.O.

SIP TAPE LOCATED INTERIOR FACE PER PBS-105

N.T.S.

Rev: 12/10/2021

PBS-204

TYPE L (2X) SPLINE



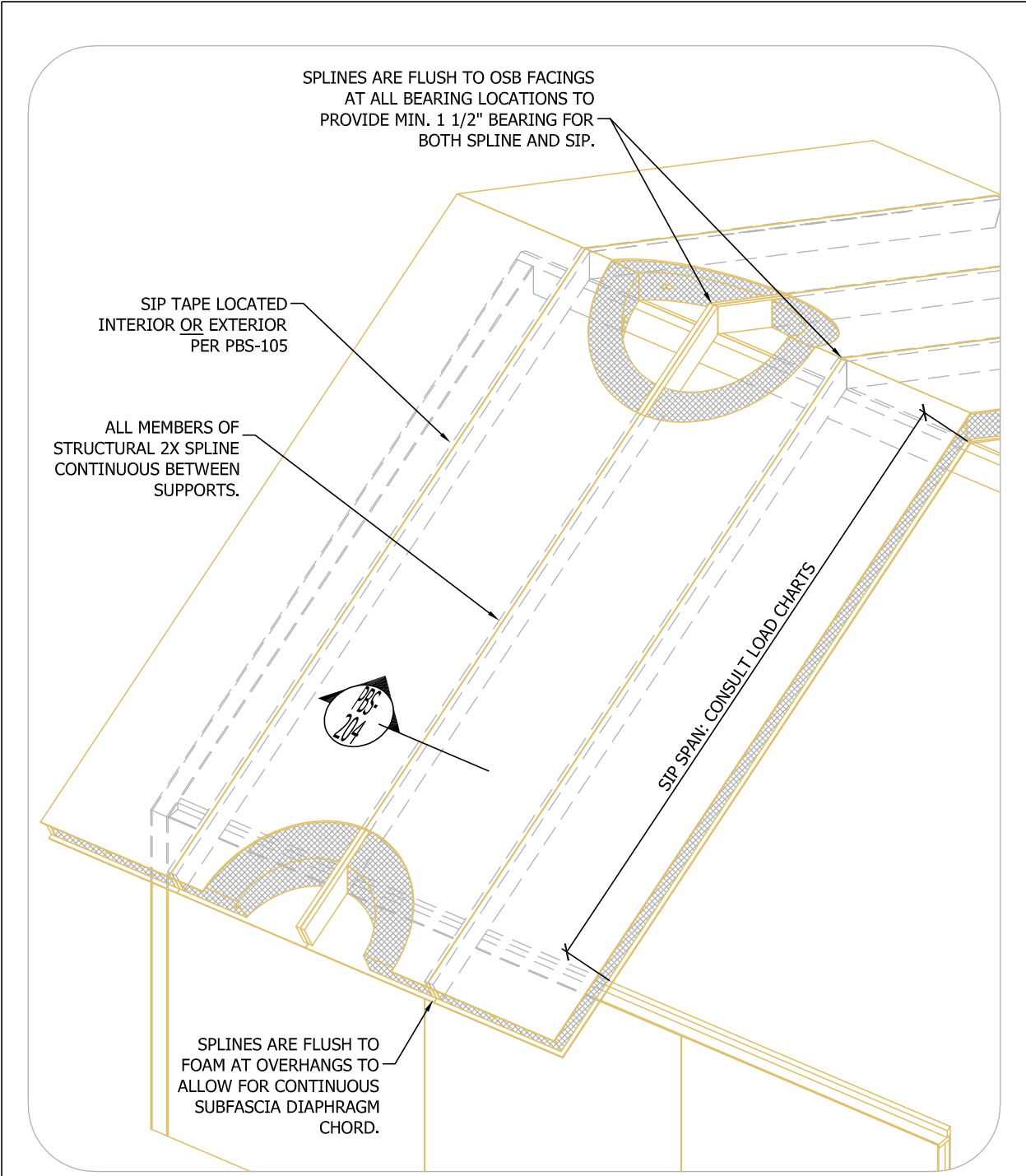

N.T.S.

Rev: 7/10/2022

PBS-205

2X SIP CONNECTION



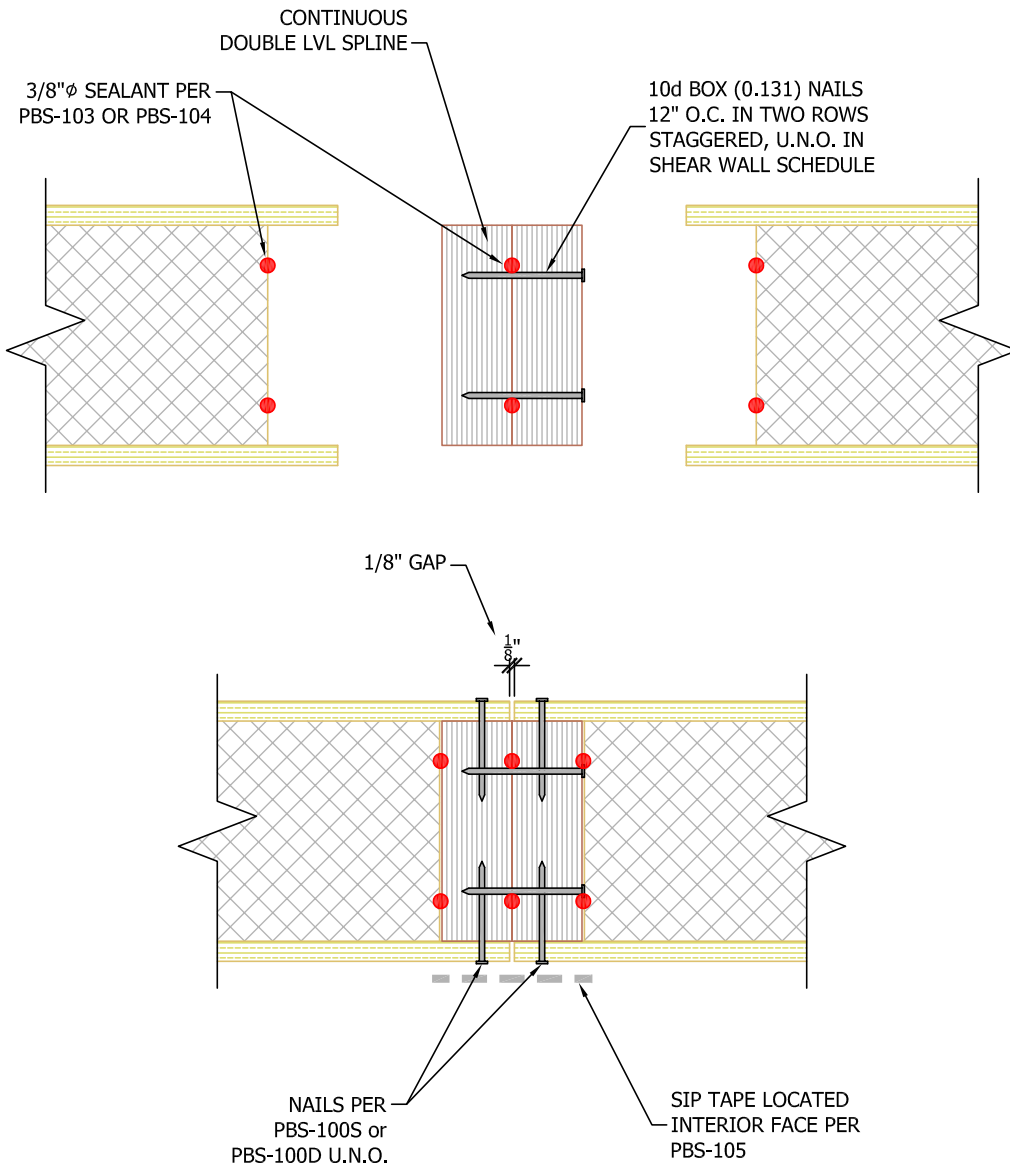

N.T.S.

Rev: 12/10/2021

PBS-206

LVL SPLINE



NOTE:

LVL WILL BE SECURED WITH SINGLE NAIL IN FACTORY PRIOR TO SHIPMENT. INSTALLER IS RESPONSIBLE FOR NAILING OFF EMBEDDED LVL PER PLAN IN THE FIELD PRIOR TO SIP PLACEMENT TO PREVENT SPLINE FROM SLIDING OUT OF SIP DURING LIFT.

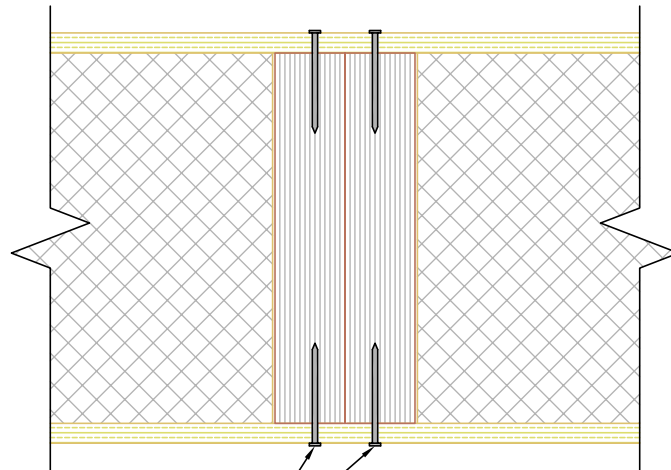

NAILS PER
PBS-100S or
PBS-100D U.N.O.

N.T.S.

Rev: 5/23/2022

PBS-207

EMBEDDED LVL SPLINE



SINGLE MEMBER LUMBER SPLINE:

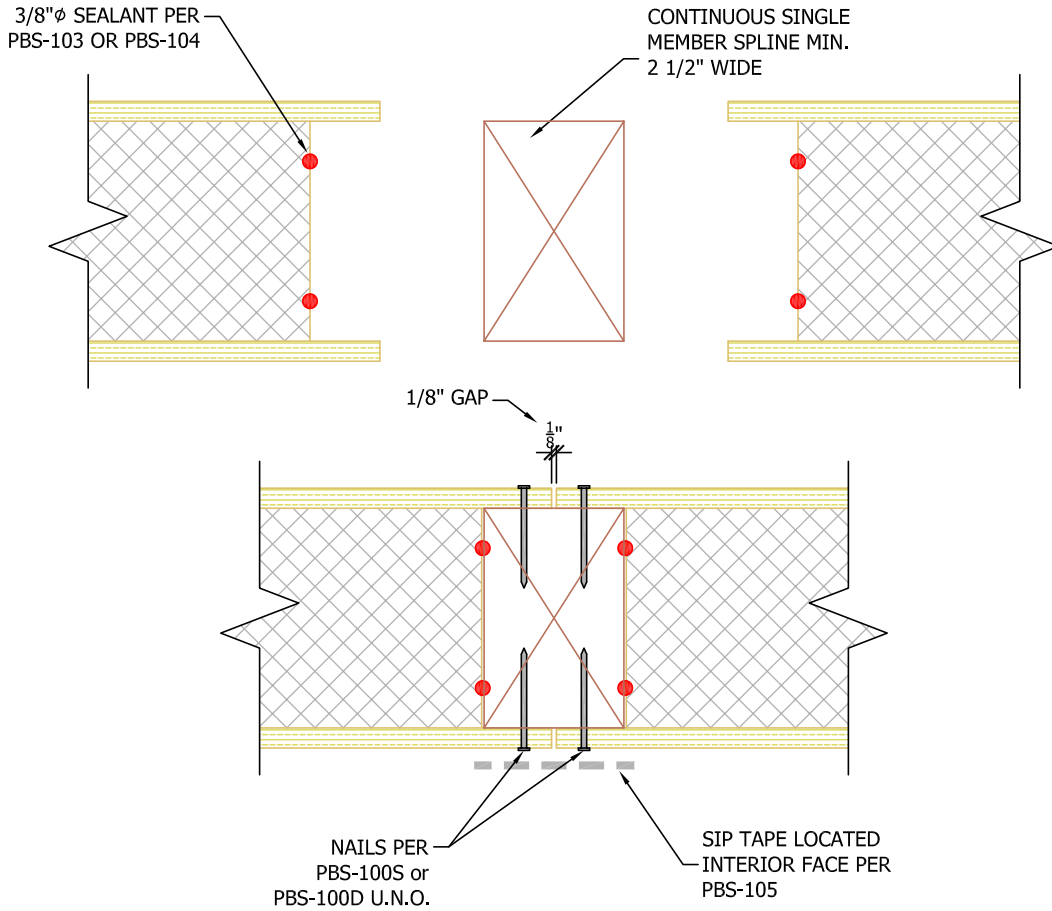

(ODD NUMBERED) 2X SPLINE:

NAIL SPLINE ASSEMBLY TOGETHER WITH 10d BOX (0.131)
 NAILS 12" O.C. IN TWO ROWS STAGGERED FOR EACH MEMBER,
 U.N.O. IN SHEAR WALL SCHEDULE. FACING TO SPLINE NAILING
 PER PBS-100S or PBS-100D U.N.O.

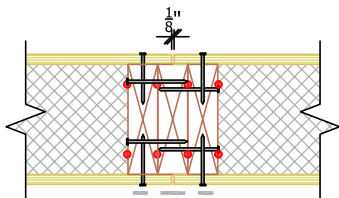

N.T.S.

(EVEN NUMBERED) 2X SPLINE:

NAIL SPLINE ASSEMBLY TOGETHER WITH 10d BOX (0.131)
 NAILS 12" O.C. IN TWO ROWS STAGGERED FOR EACH MEMBER,
 U.N.O. IN SHEAR WALL SCHEDULE. FACING TO SPLINE NAILING
 PER PBS-100S or PBS-100D U.N.O.

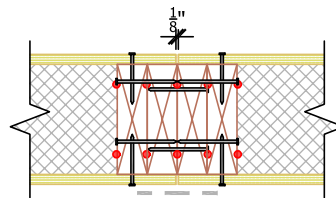

Rev: 6/3/2022

PBS-208

ALTERNATE LUMBER SPLINES



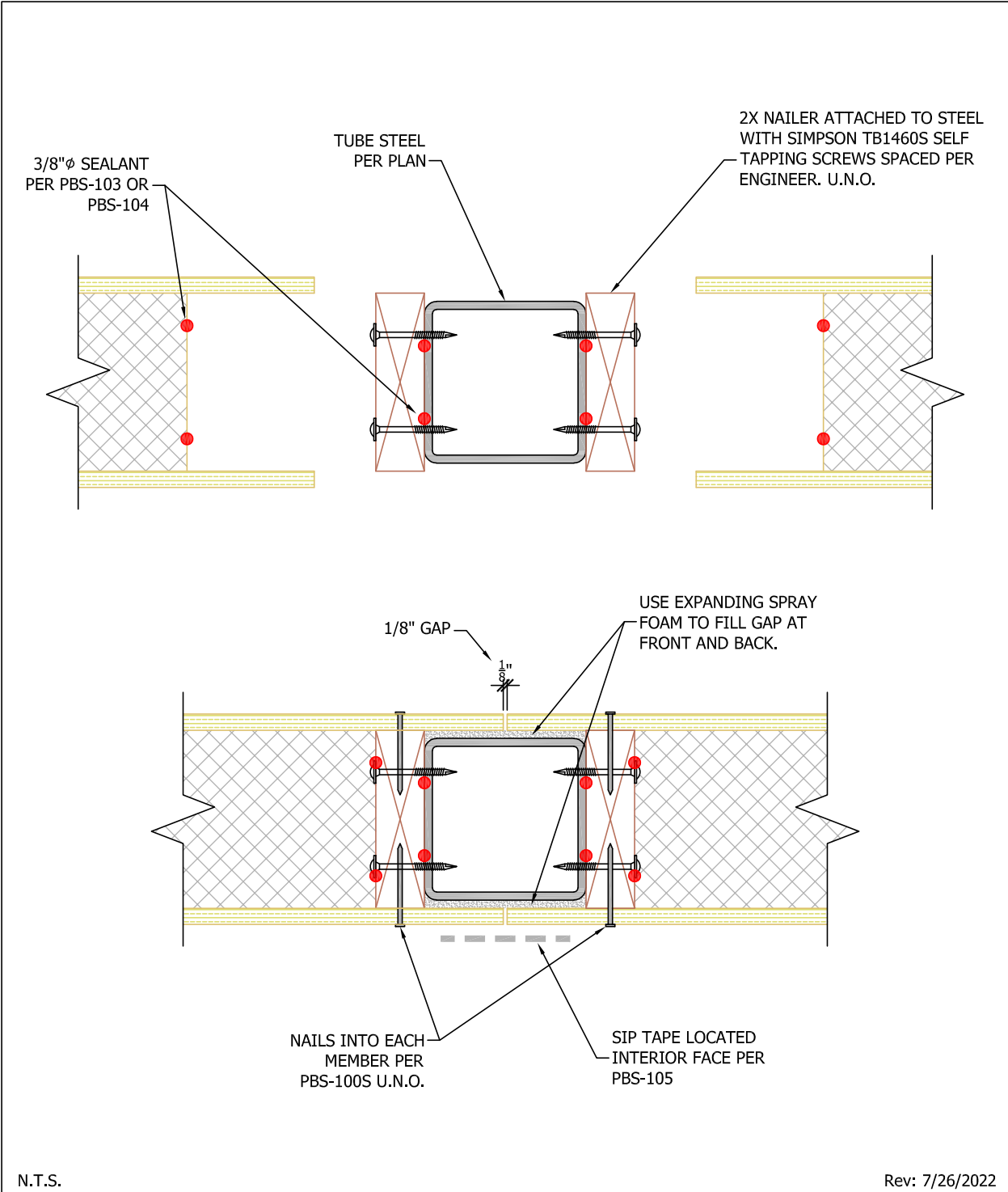

PBS-209

HSS 2X SPLINE



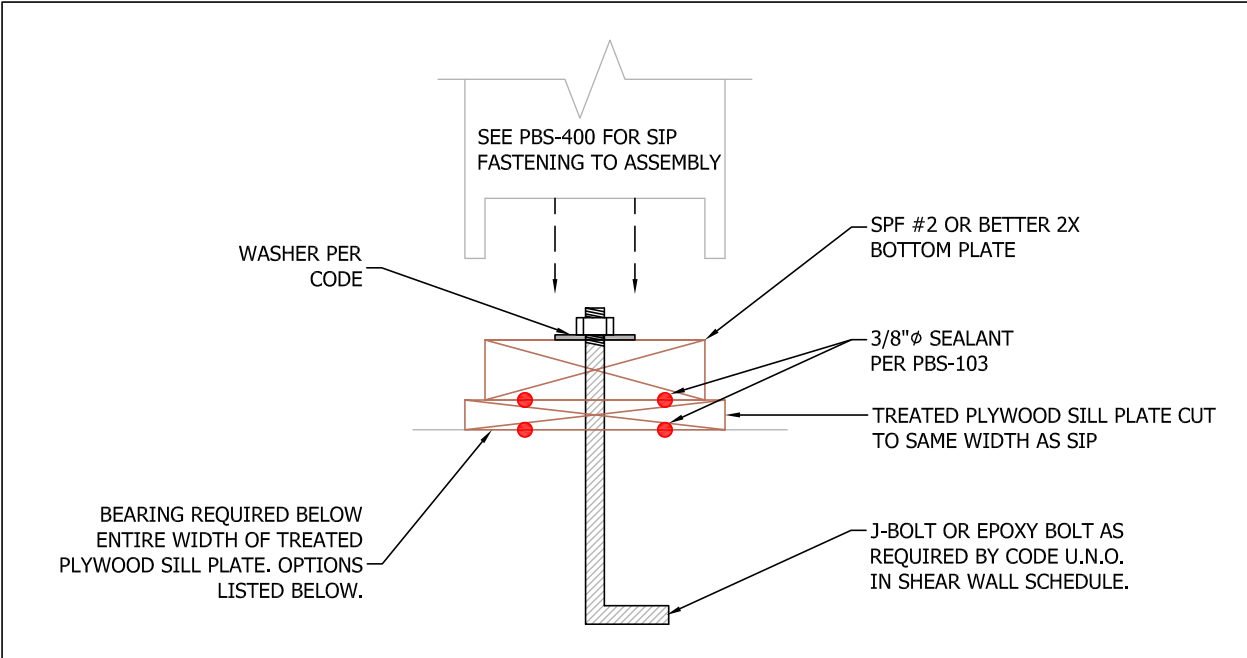

A: THICKENED SLAB

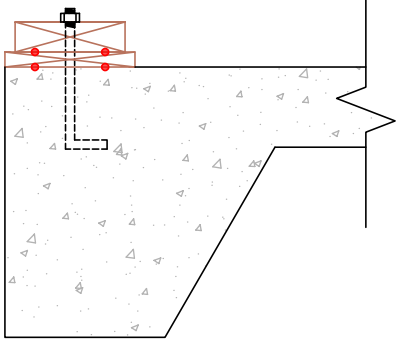

B: WALL

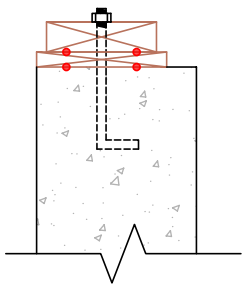

C: WALL AND SLAB ON GRADE

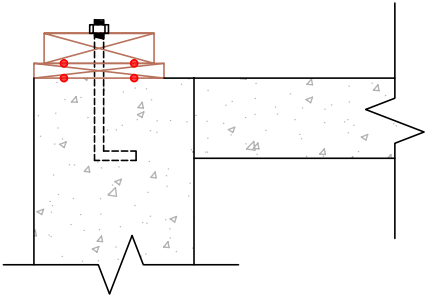

N.T.S.

D: ICF WALL

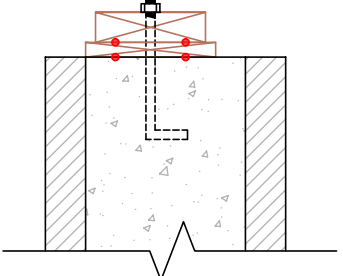

Rev: 12/10/2021

PBS-300

**CAPILLARY PLYWOOD SILL BOTTOM
PLATE FOUNDATION CONNECTION**



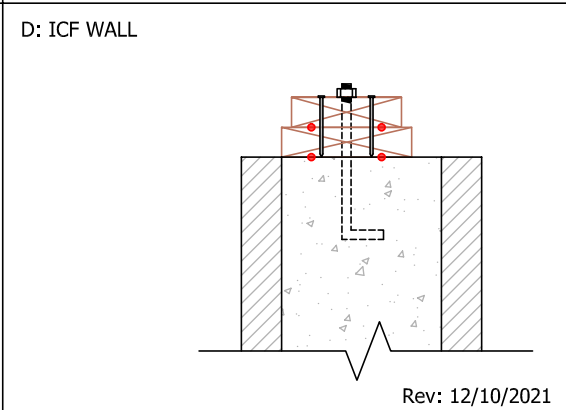
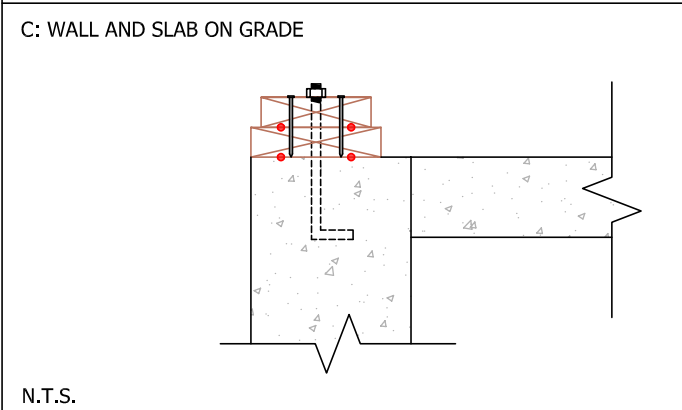
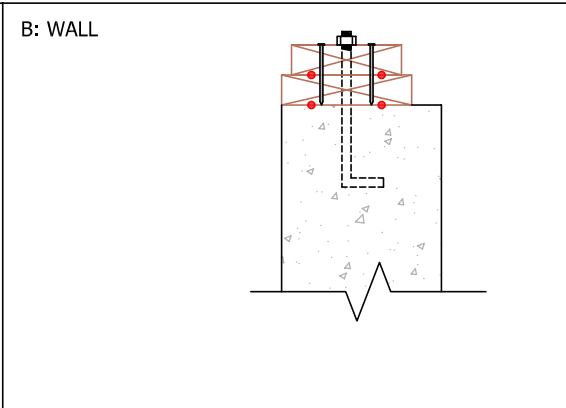
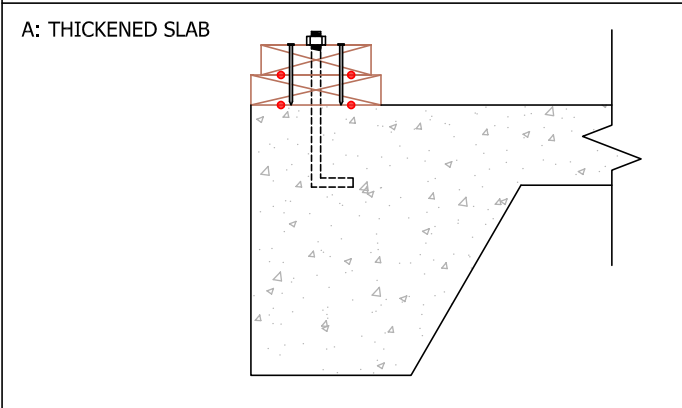
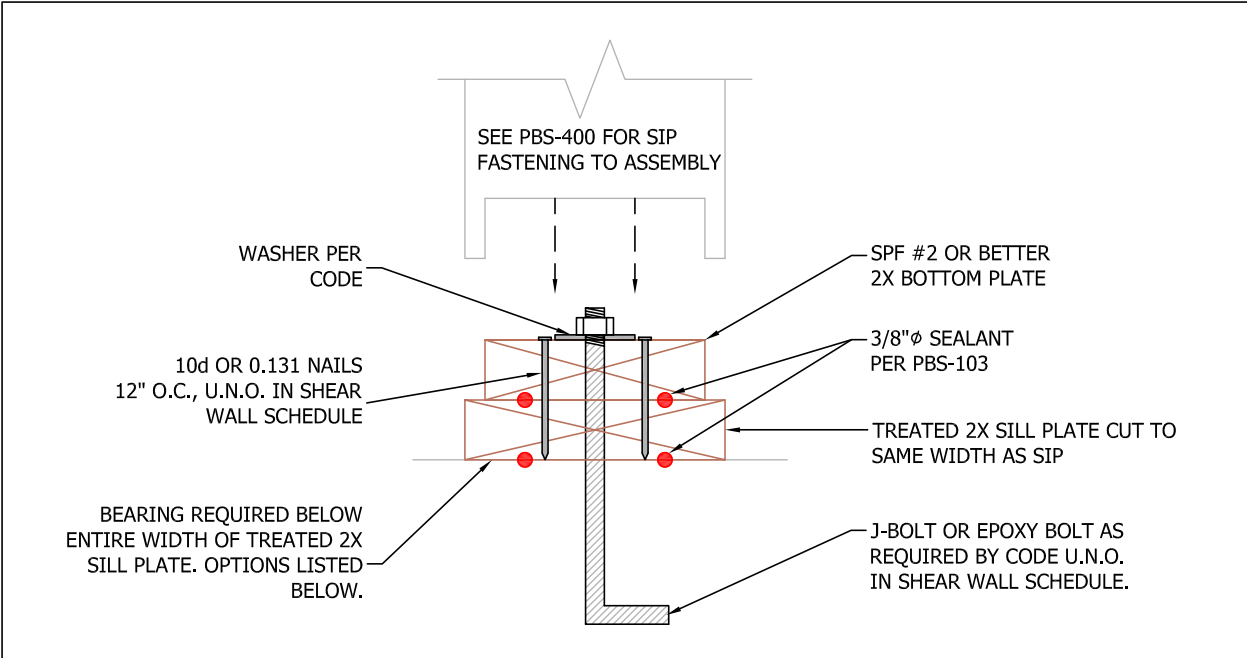

PBS-301

CAPILLARY 2X SILL BOTTOM PLATE FOUNDATION CONNECTION



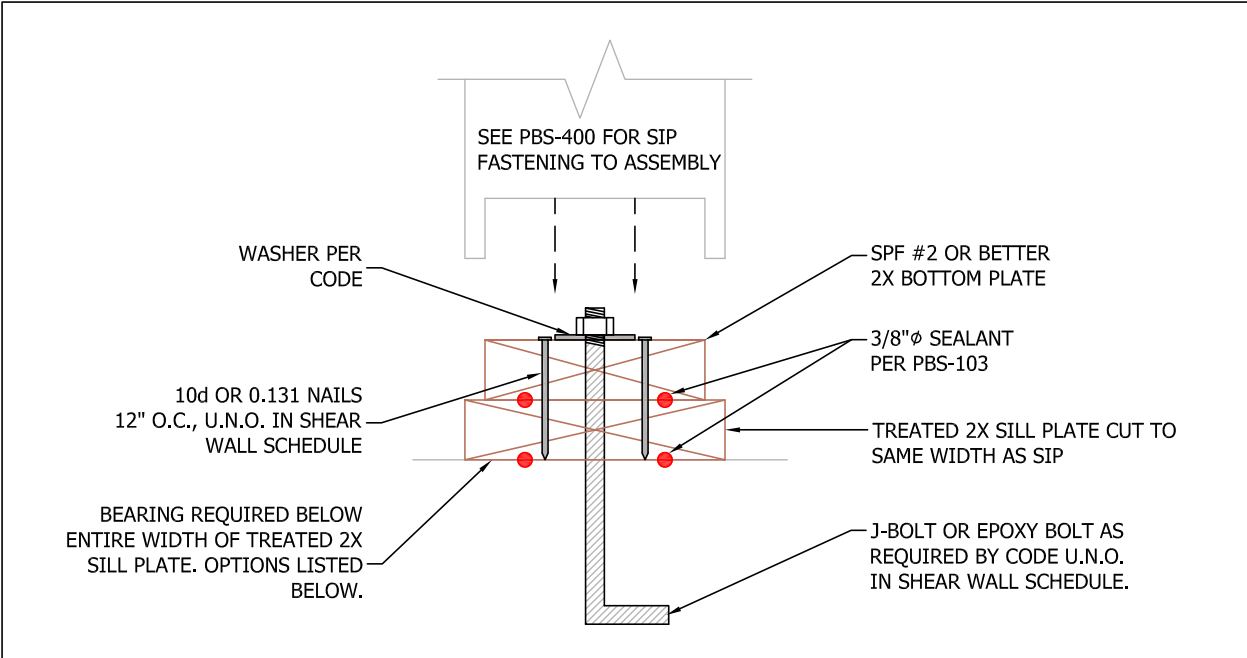

A: CANTILEVERED STRUCTURAL SILL PLATE

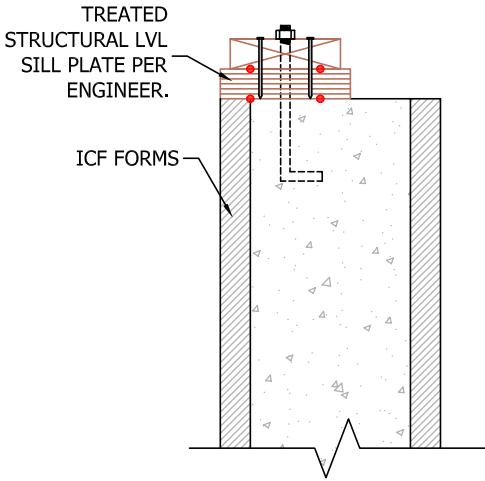

N.T.S.

B: ICF BEARING LEDGE

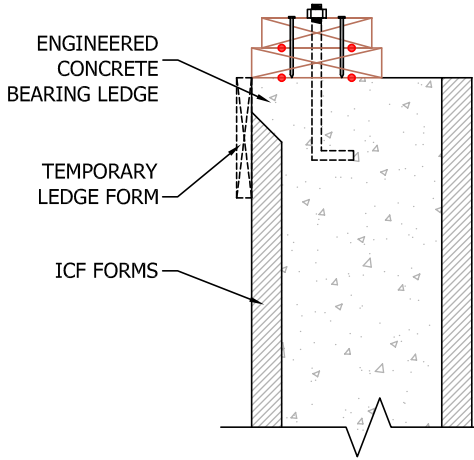

Rev: 9/19/2022

PBS-302

CANTILEVERED SILL PLATE
FOUNDATION CONNECTION



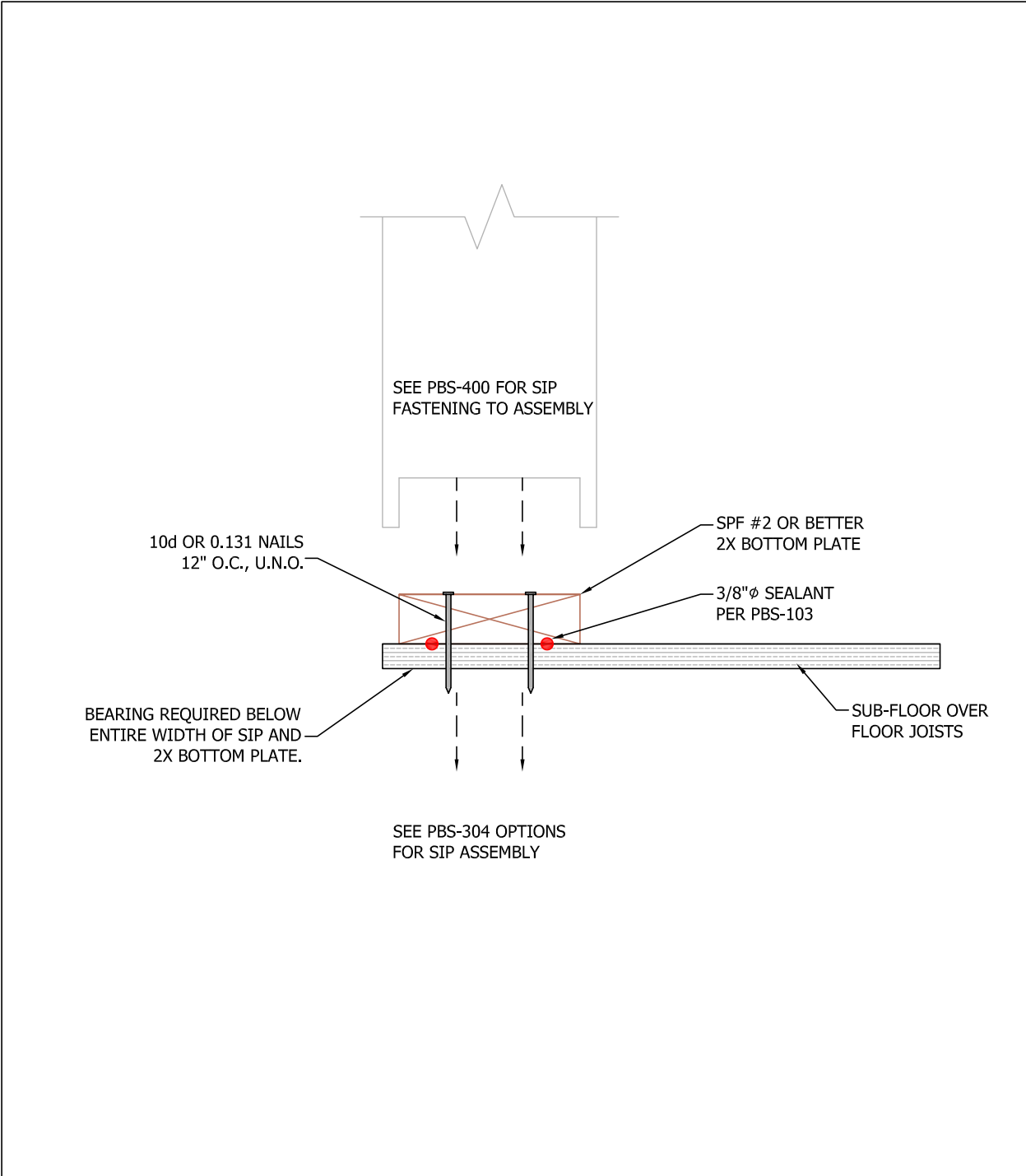

N.T.S.

Rev: 12/10/2021

PBS-303

BOTTOM PLATE



A: CONVENTIONAL FLOOR SYSTEM

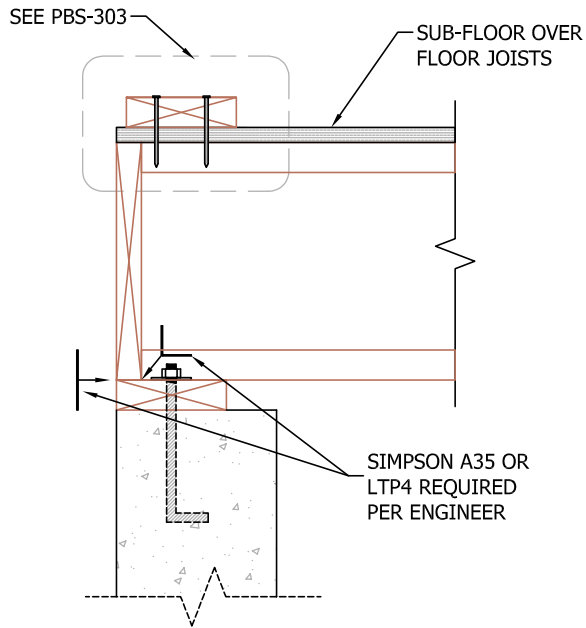

B: CONVENTIONAL FLOOR W/ GYPCRETE

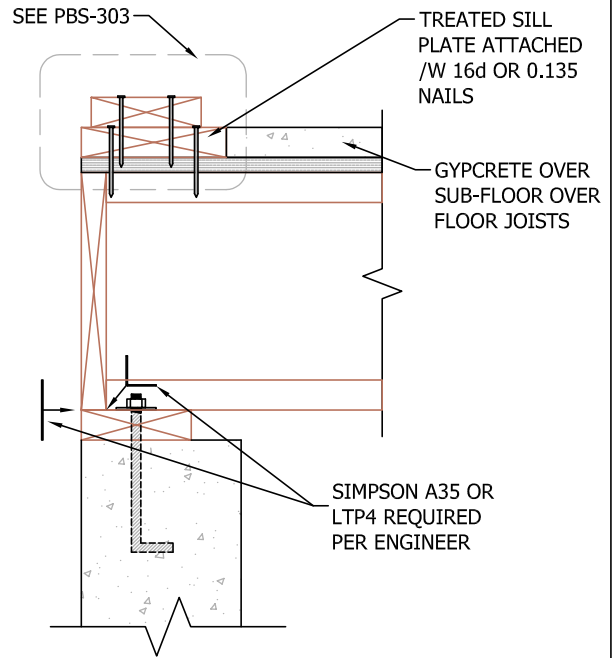

C: HANGING FLOOR SYSTEM

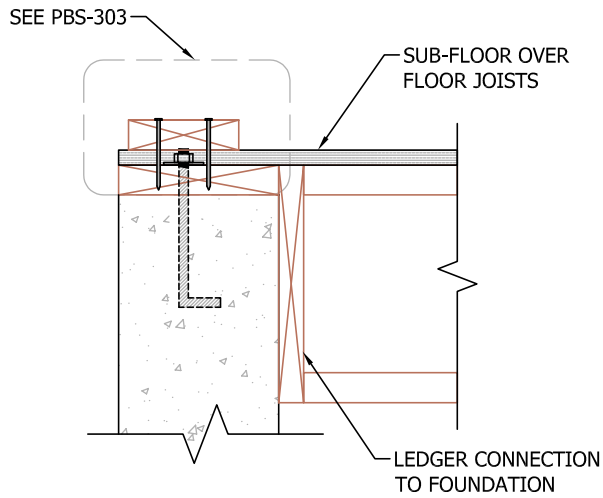

N.T.S.

D: HANGING FLOOR SYSTEM W/ GYPCRETE

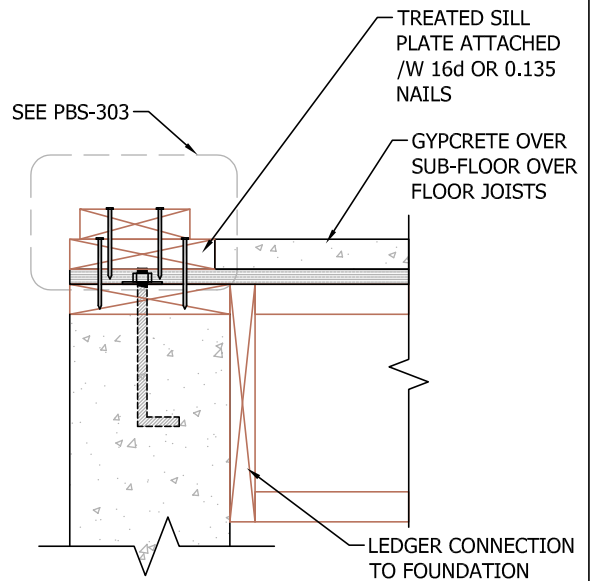

Rev: 9/19/2022

PBS-304A-D

BOTTOM PLATE
FLOOR JOIST TO CONCRETE



E: CONVENTIONAL FLOOR SYSTEM

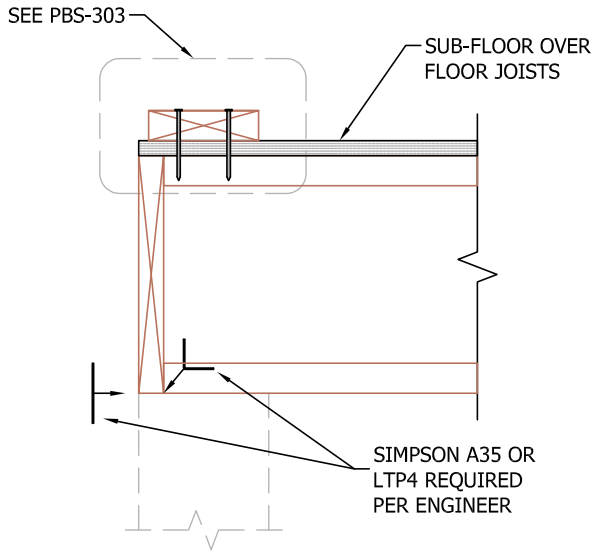

F: CONVENTIONAL FLOOR SYSTEM W/ GYPCRETE

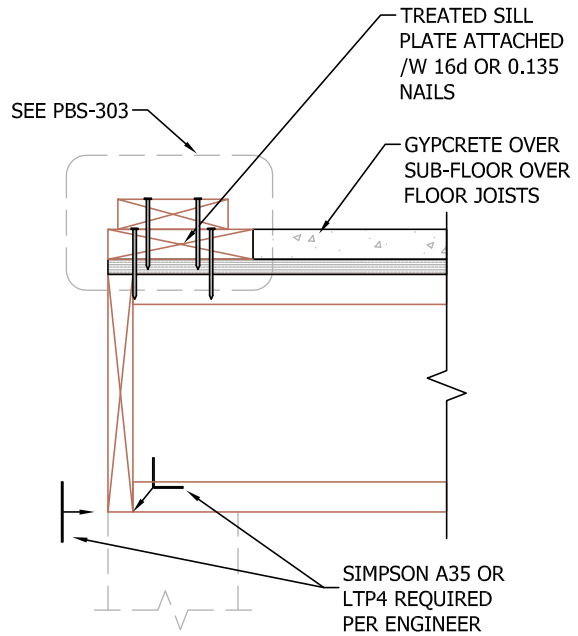

G: TOP CHORD FLOOR SYSTEM

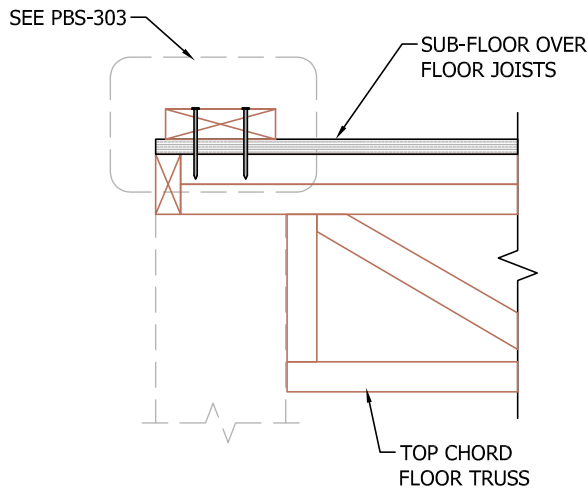

N.T.S.

H: HANGING FLOOR SYSTEM

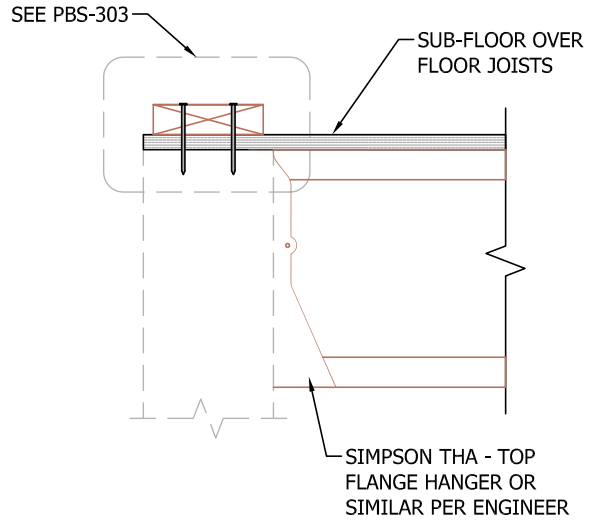

Rev: 2/21/2023

PBS-304E-H

BOTTOM PLATE FLOOR JOISTS TO WALL



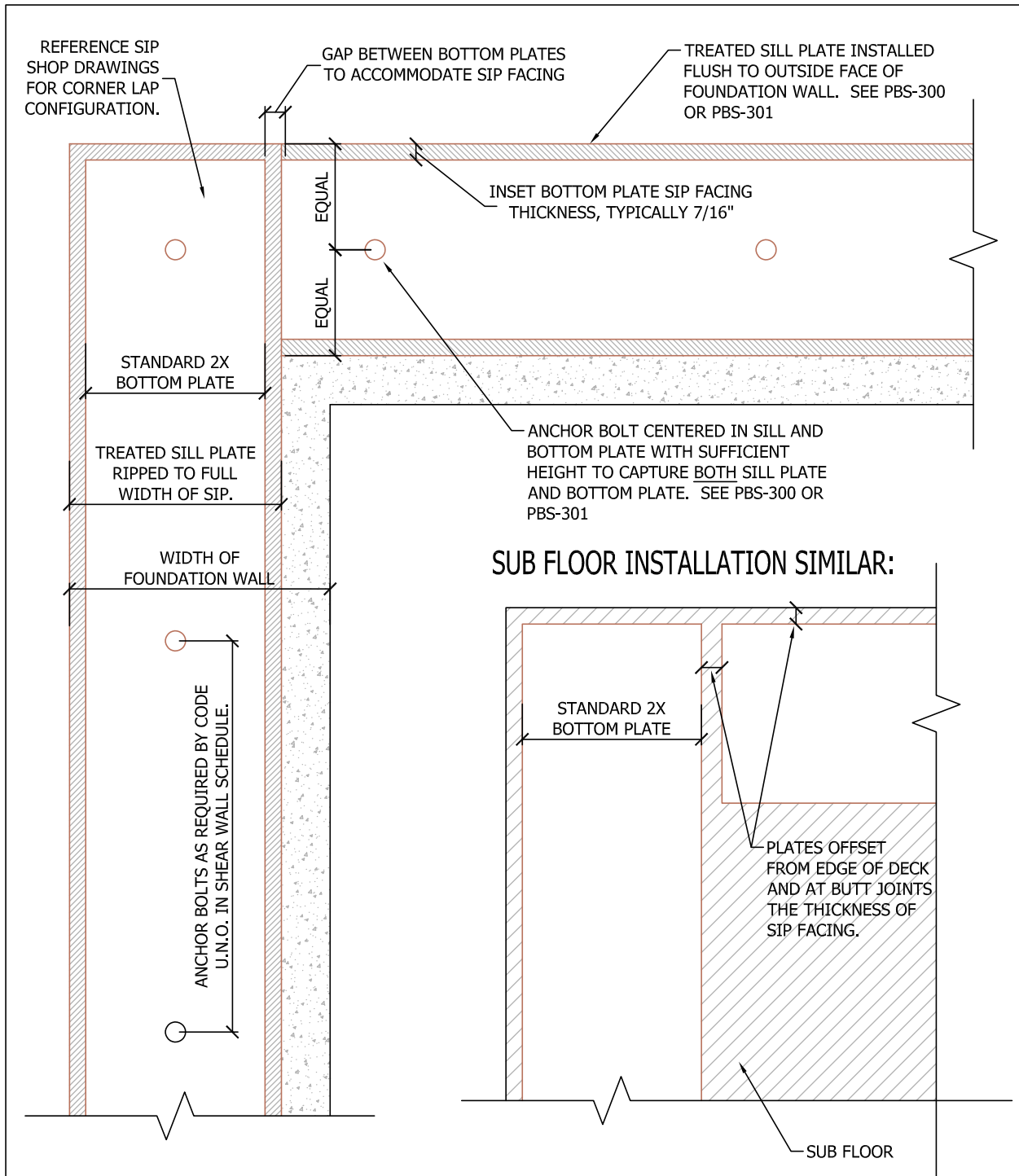

N.T.S.

Rev: 12/10/2021

PBS-305

BOTTOM PLATE PLACEMENT



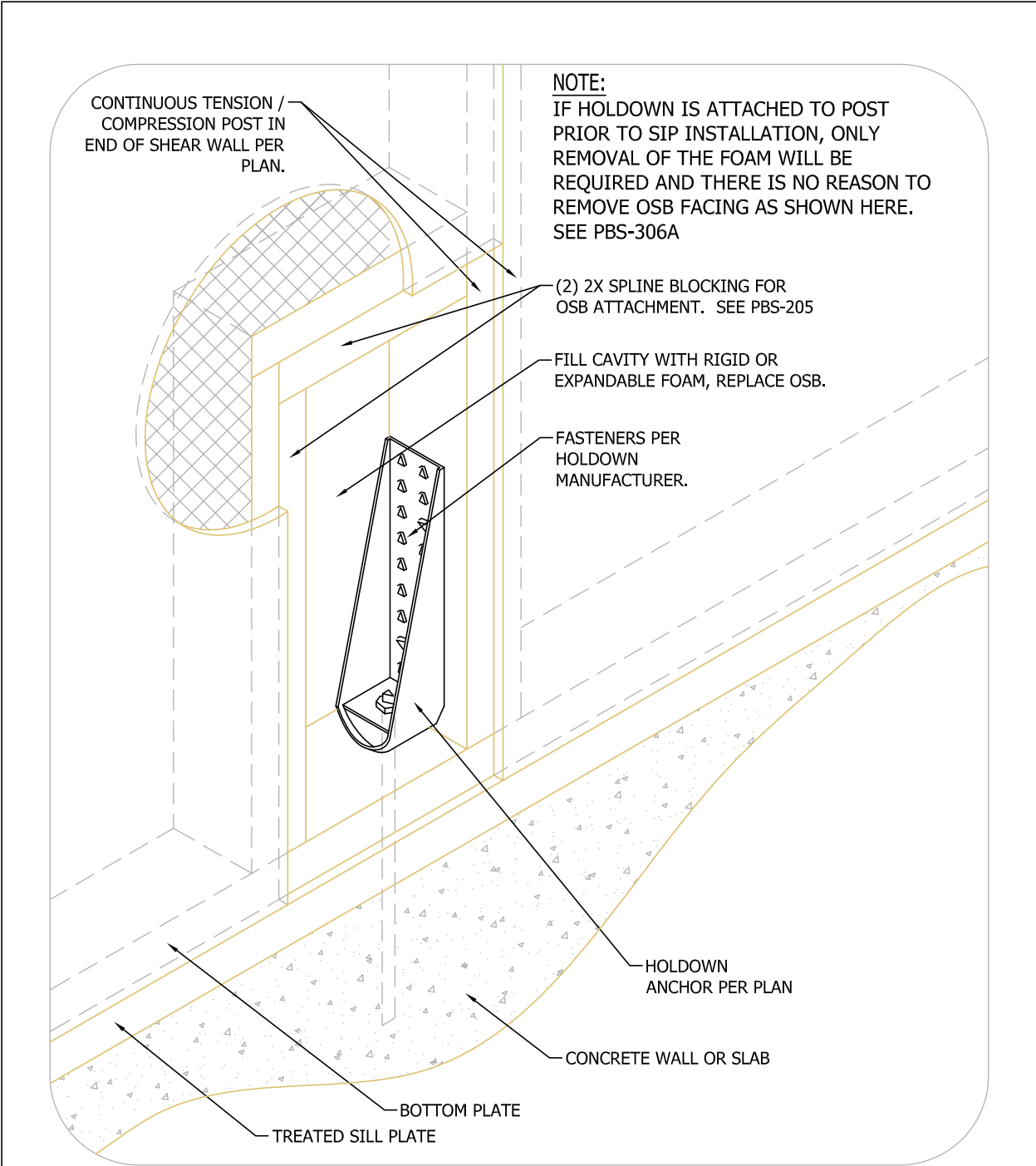

NOTE:
 IF HOLDOWN IS ATTACHED TO POST
 PRIOR TO SIP INSTALLATION, ONLY
 REMOVAL OF THE FOAM WILL BE
 REQUIRED AND THERE IS NO REASON TO
 REMOVE OSB FACING AS SHOWN HERE.
 SEE PBS-306A

N.T.S.

Rev: 12/10/2021

PBS -306

HDU TYPE HOLDOWN



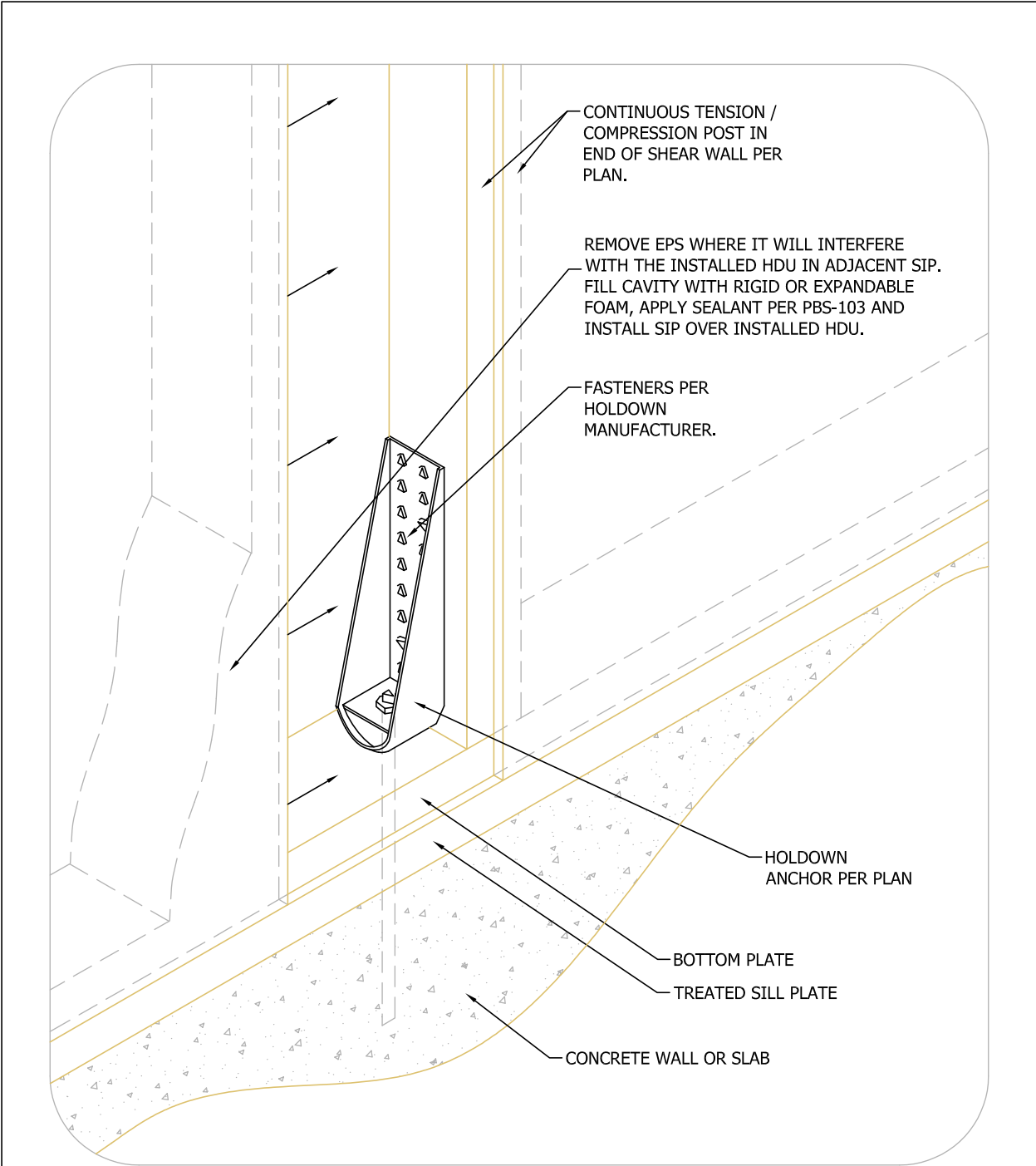

N.T.S.

Rev: 12/10/2021

PBS-306A

**HDU TYPE HOLDOWN
INSTALLED PRIOR TO SIP**



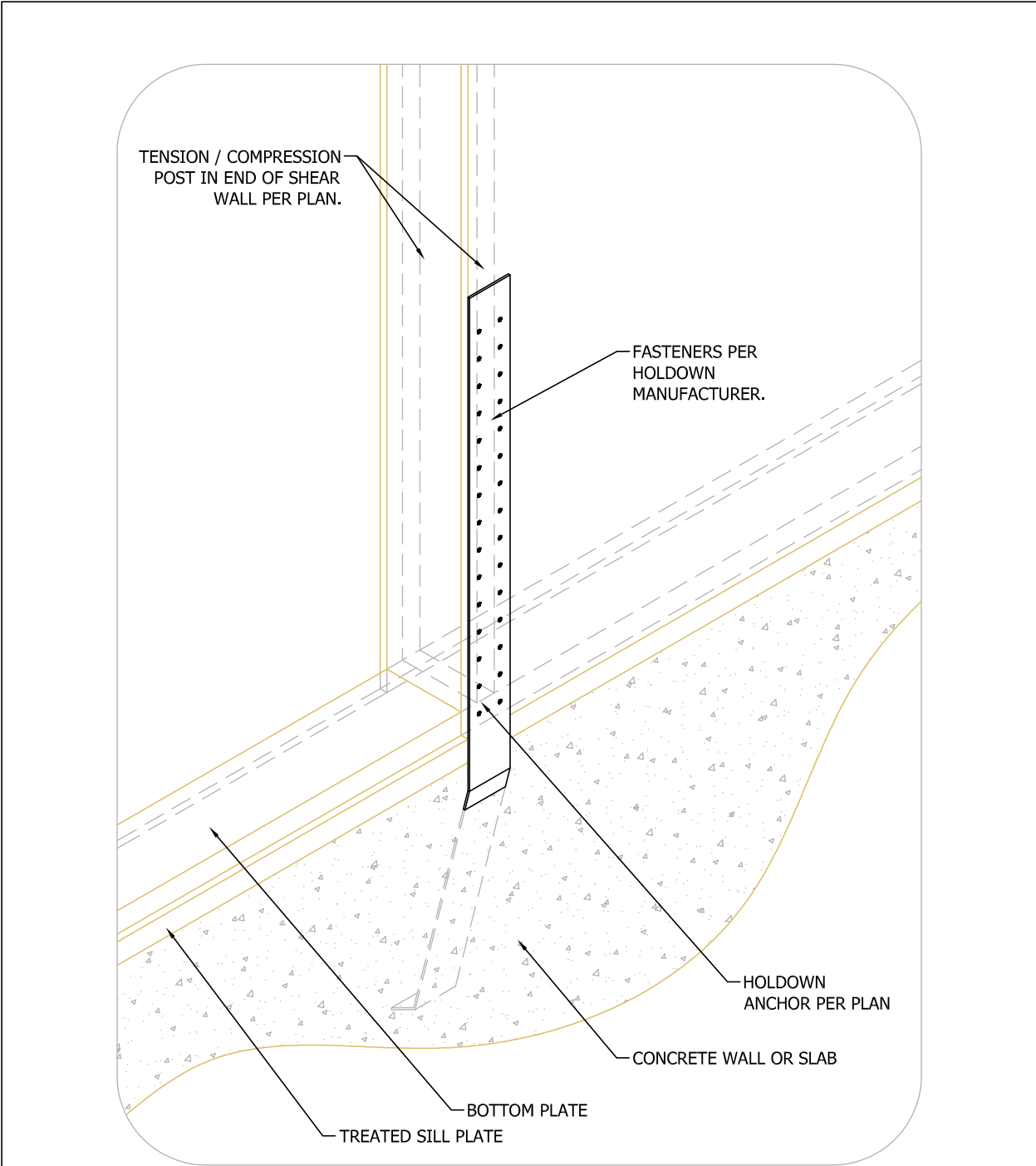

N.T.S.

Rev: 12/10/2021

PBS-307

STRAP HOLDOWN



ASSEMBLY SEQUENCE:

1. SILL AND BOTTOM PLATE TO FOUNDATION
2. SIP WALL
3. FLOOR SYSTEM

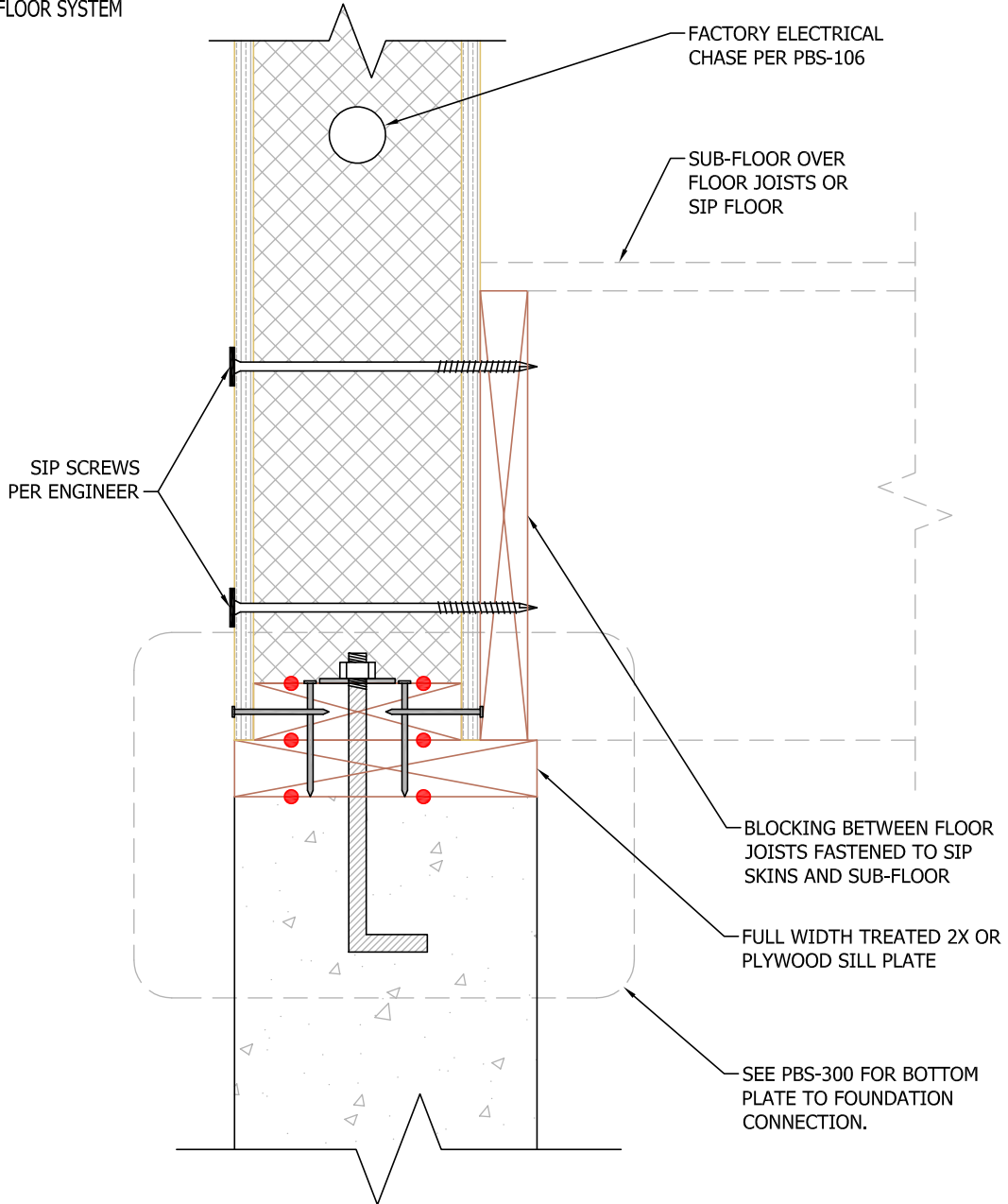

N.T.S.

Rev: 9/19/2022

PBS-308

**BOTTOM PLATE INSULATED RIM
FOUNDATION CONNECTION**



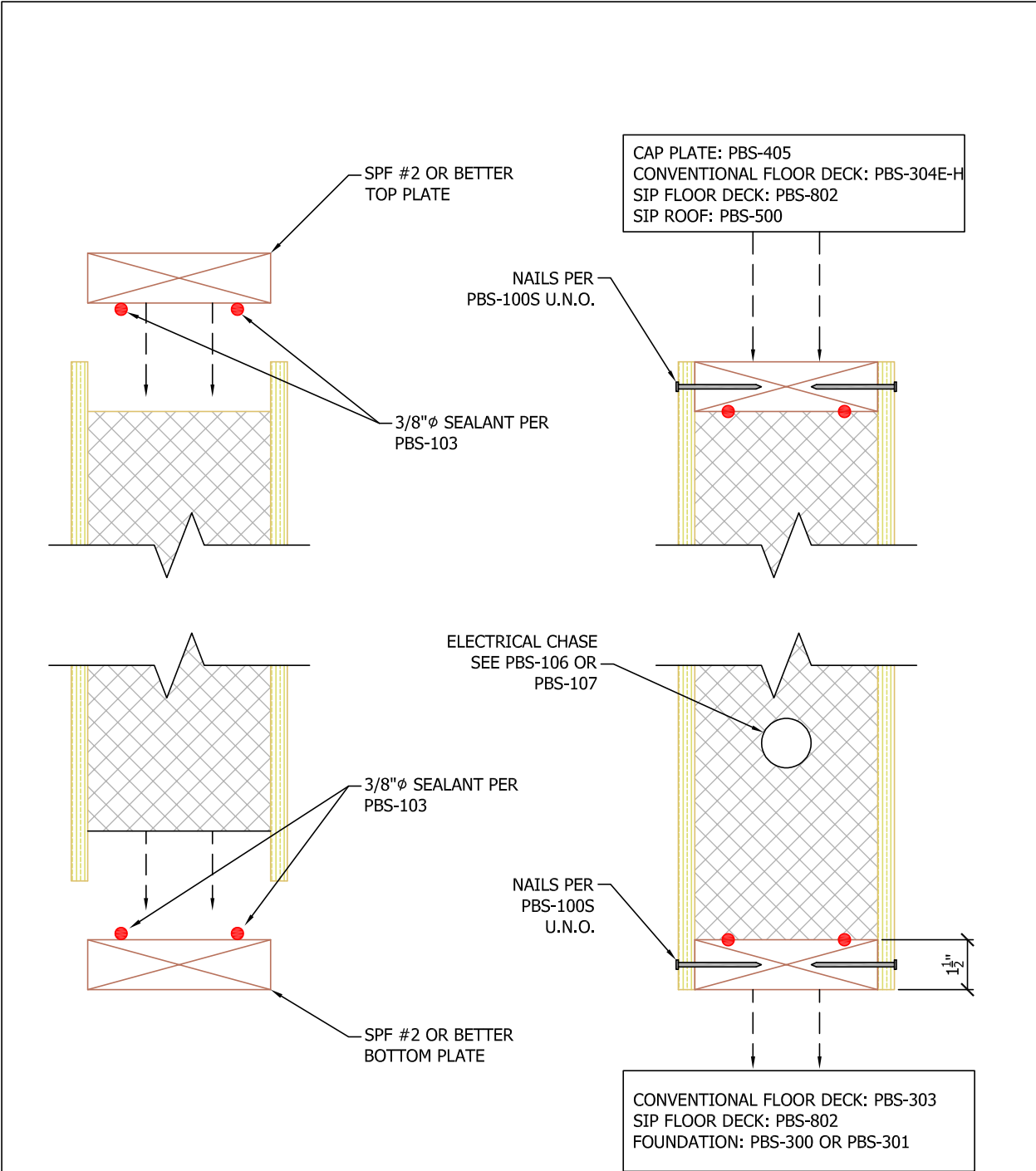

N.T.S.

Rev: 6/6/2023

PBS-400

SIP WALL PLATE



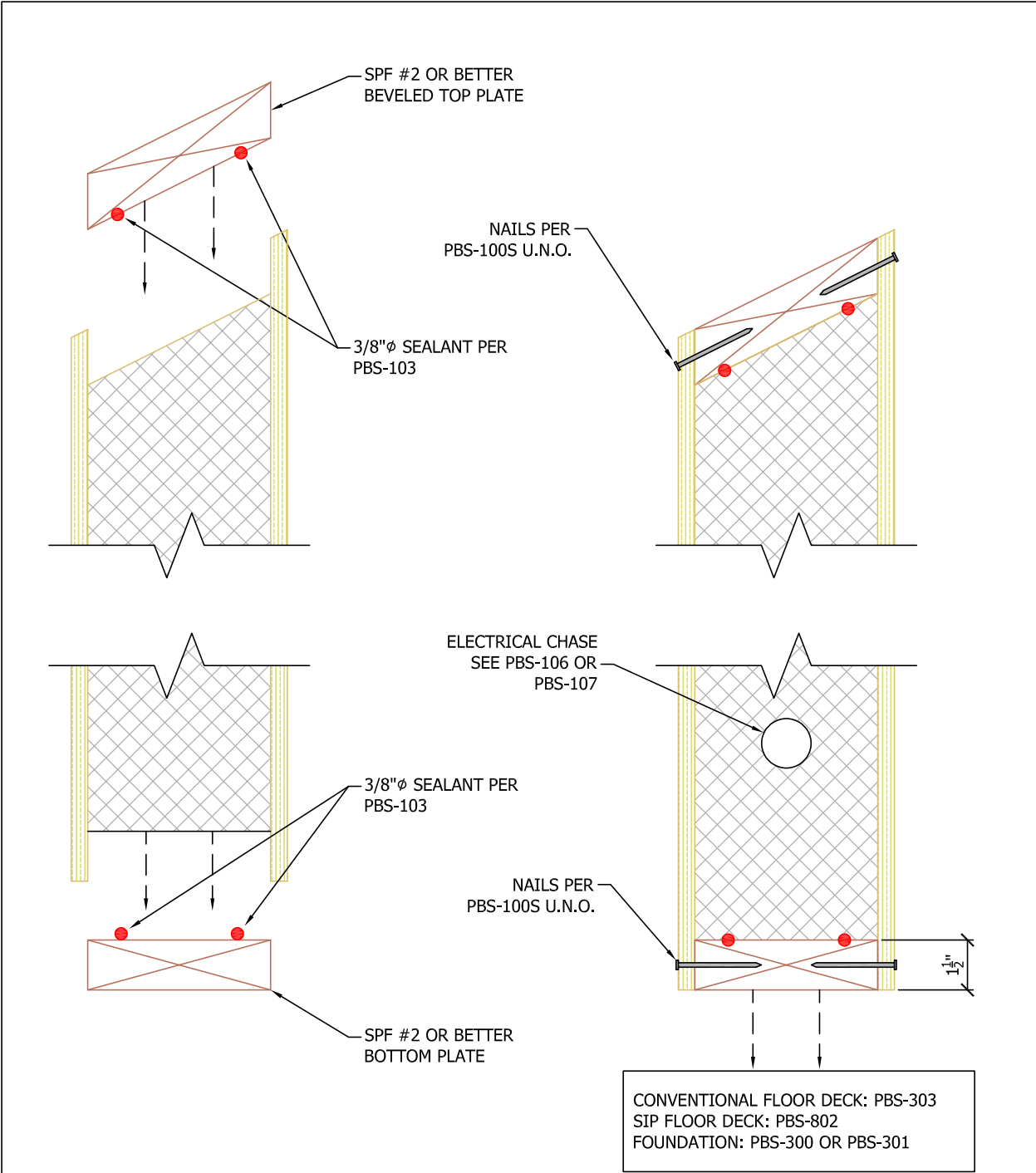

N.T.S.

Rev: 6/6/2023

PBS-401

**SIP WALL PLATE
BEVELED TOP**



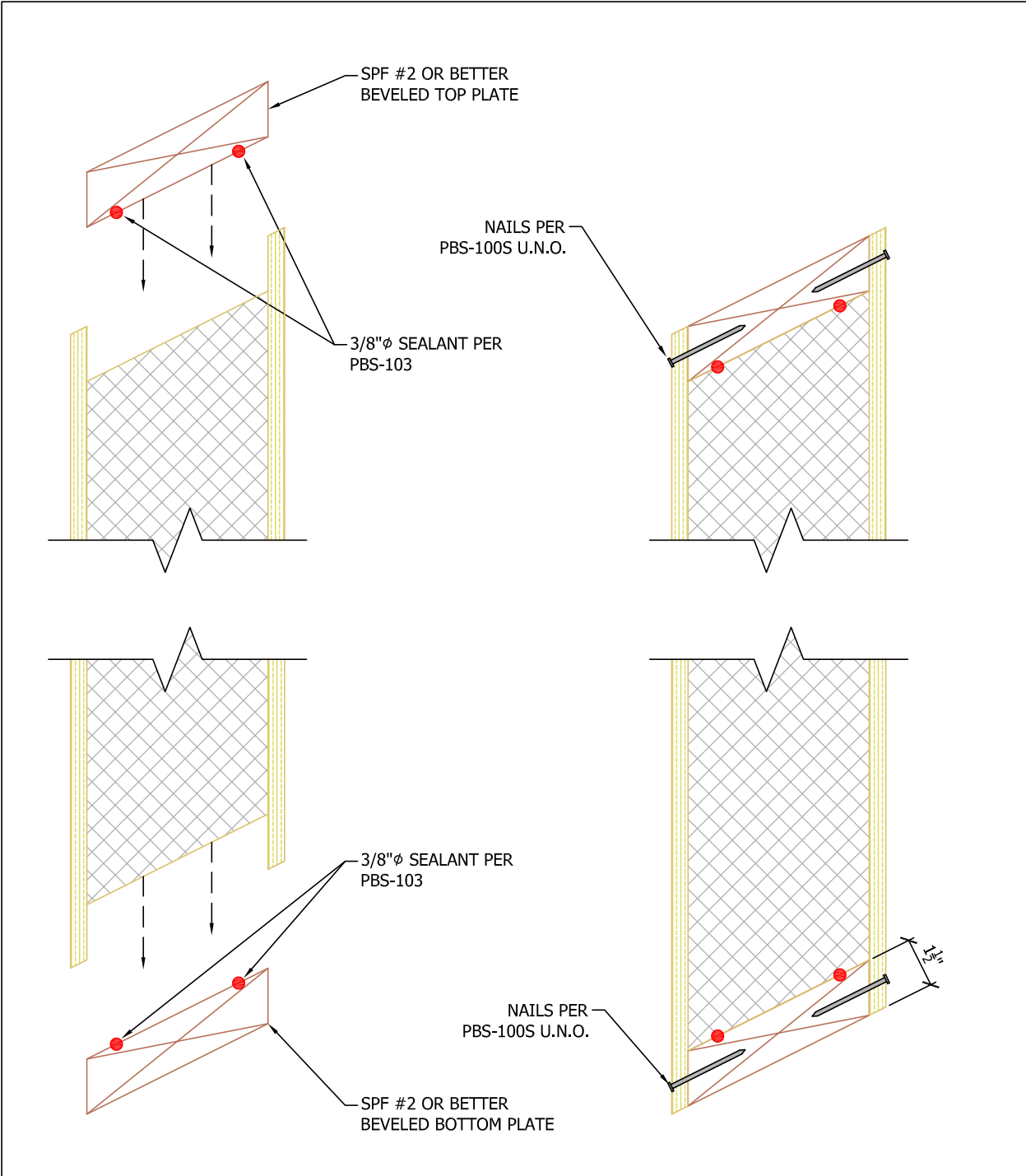

N.T.S.

Rev: 12/10/2021

<p>PBS-402</p>	<p>BEVELED SIP WALL PLATE TOP AND BOTTOM</p>	
----------------	--	--

NOTE:
SEE PBS-305 FOR BOTTOM
PLATE PLACEMENT

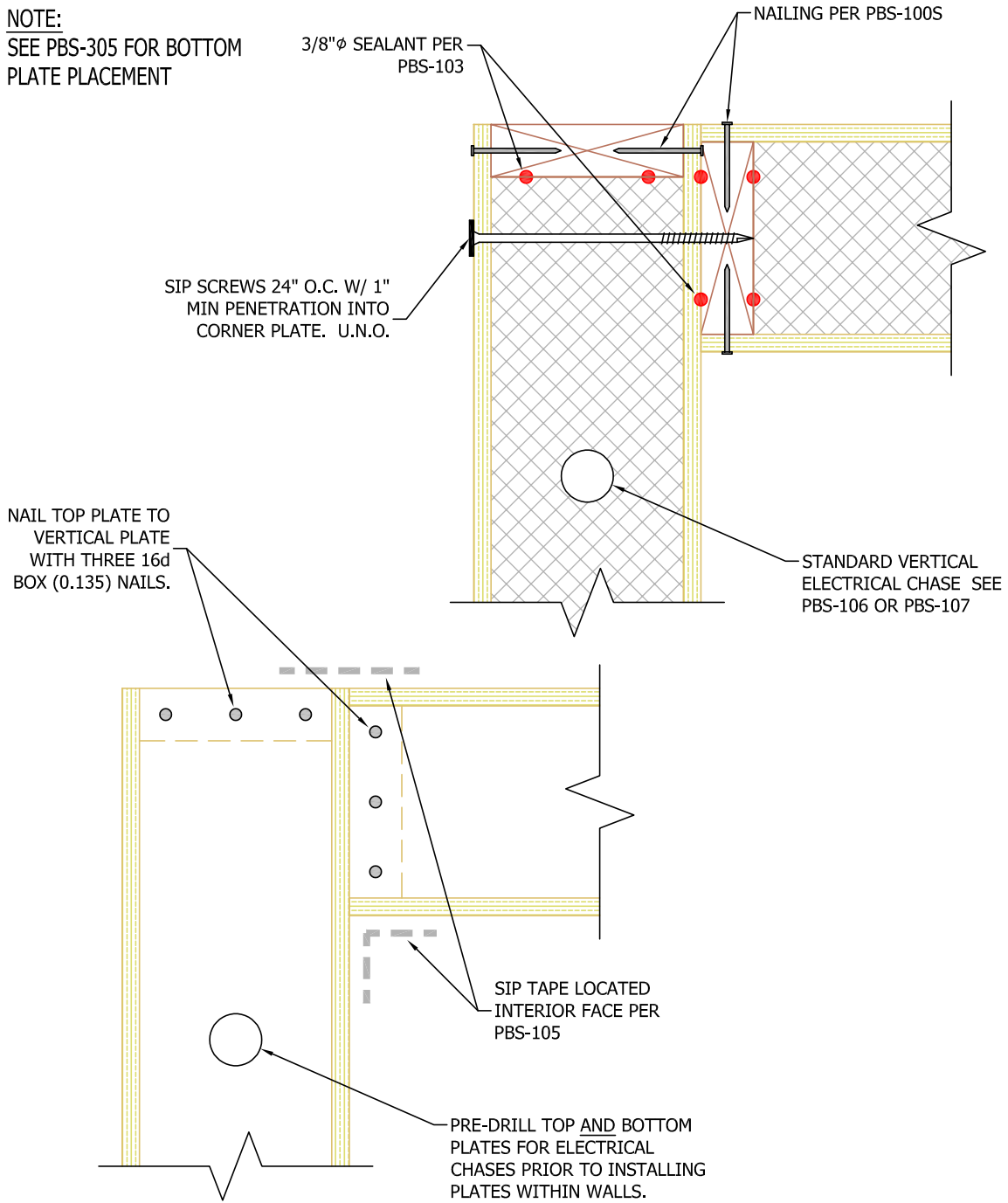

N.T.S.

Rev: 12/10/2021

PBS-403

WALL CORNER



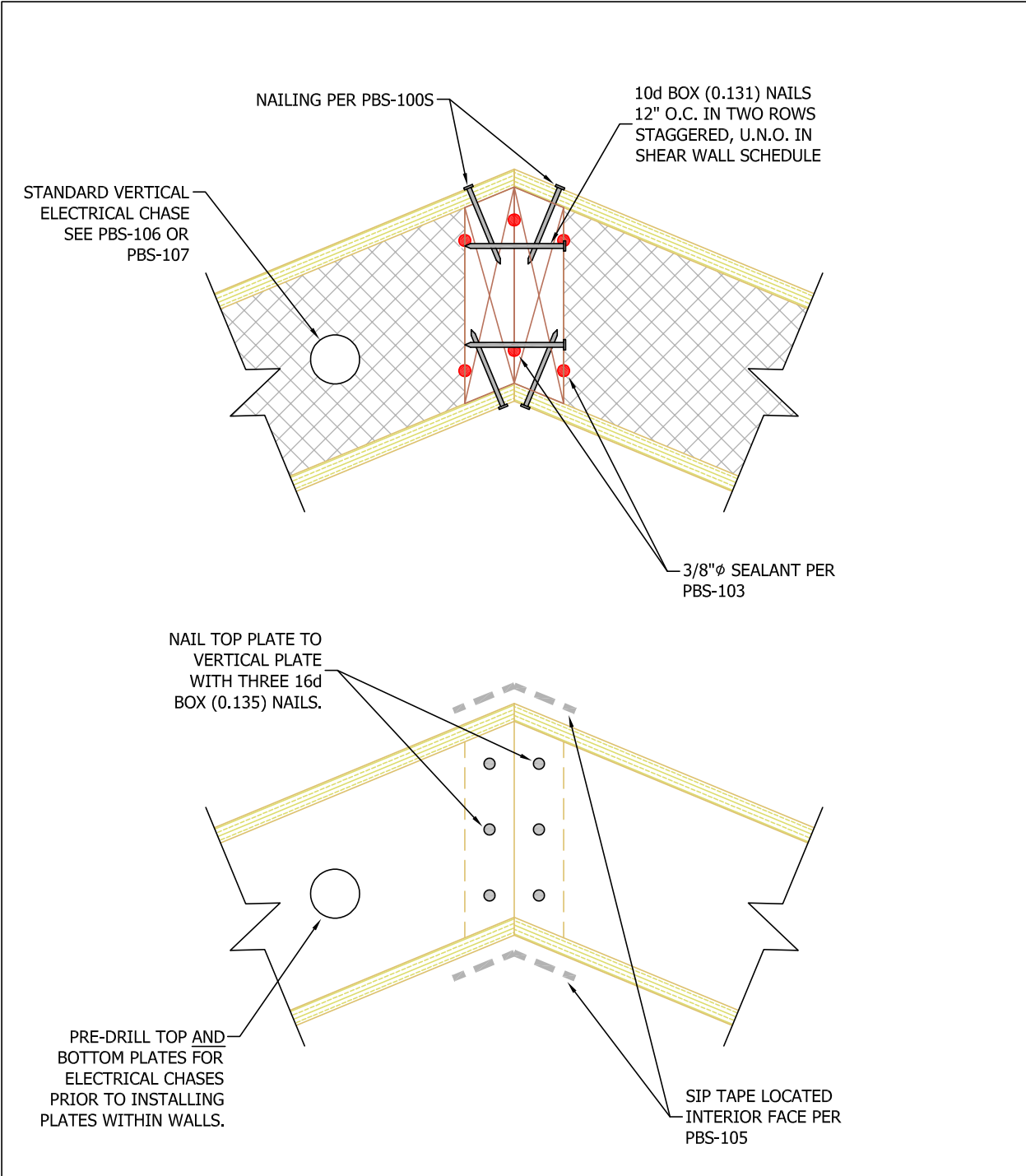

N.T.S.

Rev: 12/10/2021

PBS-404

WALL ANGLED CORNER



NOTES:

1. FACINGS ARE THE LOAD BEARING COMPONENT IN A SIP. WIDTH OF ANY LUMBER INSTALLED TO TOP OF SIP WALL MUST BE FULL WIDTH OF SIP IN ORDER TO TRANSFER LOADS TO FACINGS.
2. CAP PLATE MAY BE USED TO INCREASE POINT LOAD CAPACITY AND/OR INCREASE WALL HEIGHT.
3. NON-STRUCTURAL SPACER MAY BE USED TO INCREASE WALL HEIGHT ONLY.

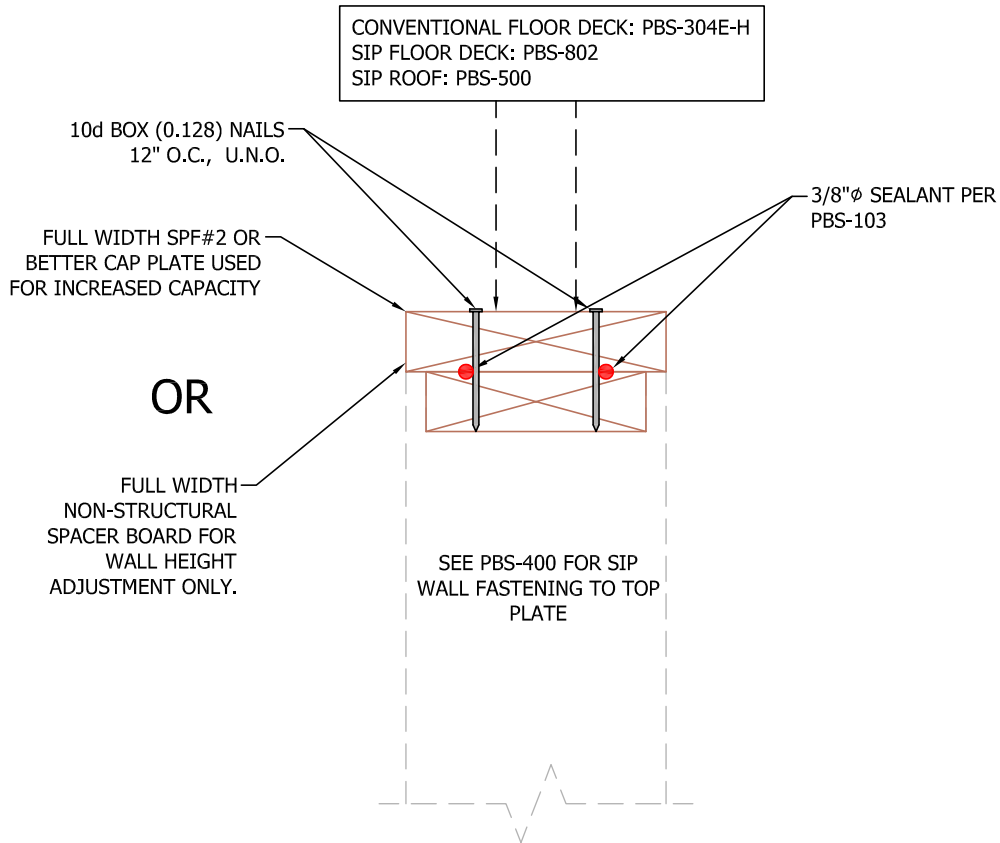

N.T.S.

Rev: 7/21/2022

PBS -405

CAP PLATE CONNECTION



NOTE:

FACINGS ARE THE LOAD BEARING COMPONENT IN A SIP. WIDTH OF ANY LUMBER INSTALLED TO BOTTOM OF SIP WALL MUST BE FULL WIDTH OF SIP IN ORDER TO TRANSFER LOADS TO BEARING BELOW.

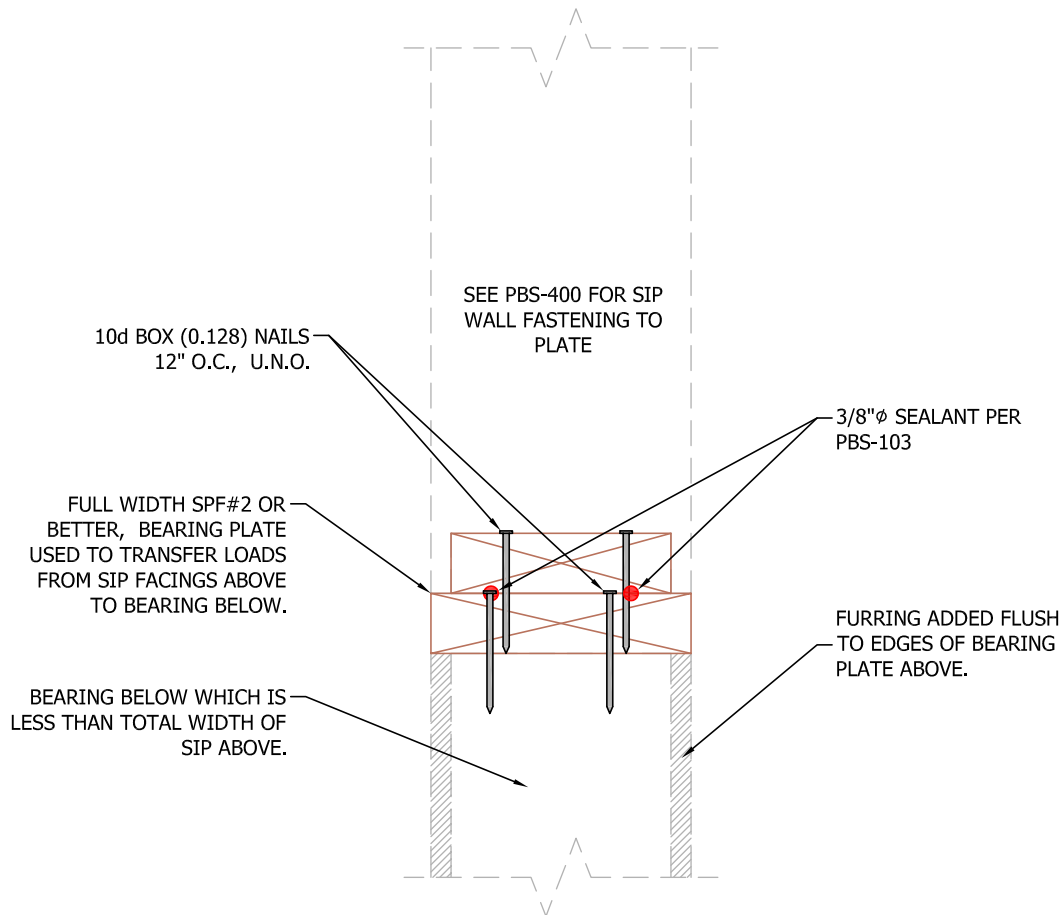

N.T.S.

Rev: 7/21/2022

PBS-406

BEARING PLATE



STEP #1:

1. PRE-DRILL ELECTRICAL CHASES PER PBS-106.
2. INSTALL KINGS, TRIMMERS, & NAILERS INTO SIP USING (2) 3/8" BEADS OF SEALANT PER PBS-103 AT ALL INTERFACES (LUMBER TO LUMBER AND LUMBER TO SIP).
3. ASSEMBLE SIPS ON THE GROUND AND LIFT INTO PLACE OR ASSEMBLE VERTICALLY, ONE PIECE AT A TIME.

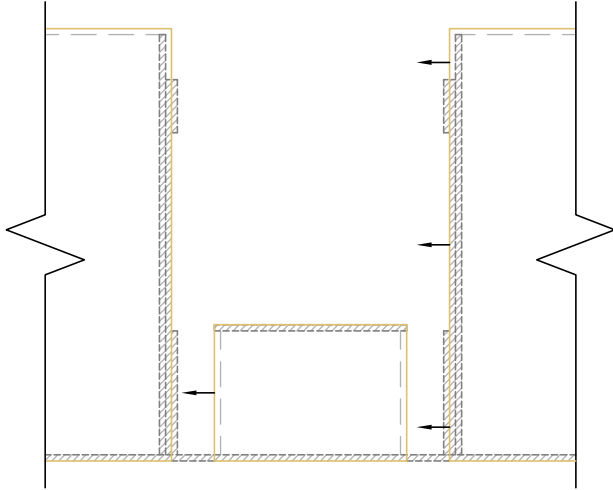

STEP #2:

1. DROP FILLER SIP FROM ABOVE OR BELOW 2x NAILER MEMBERS, WHICHEVER METHOD IS EASIEST.
2. CUT HEADER TO LENGTH FROM FACE OF KING TO FACE OF KING. (SEE PBS-411 FOR ASSEMBLIES).

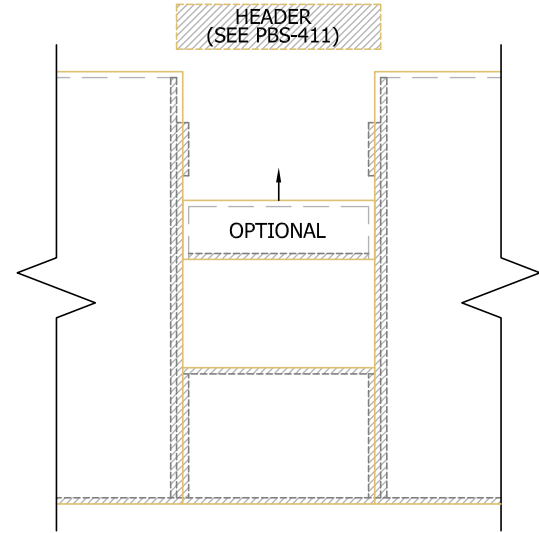

STEP #3:

1. DROP IN HEADER FROM ABOVE.
2. INSTALL CONTINUOUS TOP PLATE ACROSS HEADER AND SIPS.

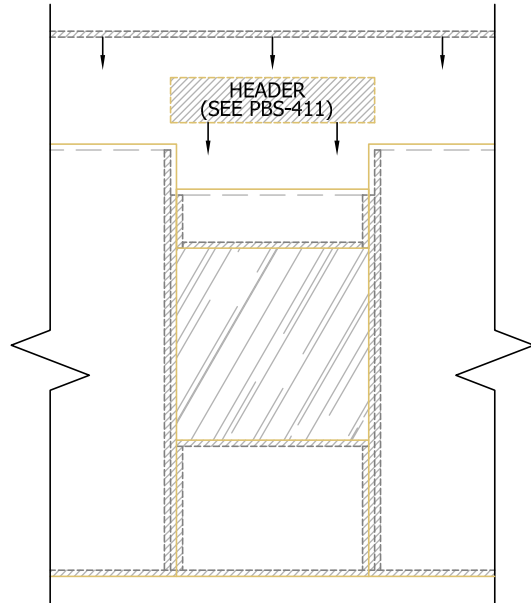

N.T.S.

NOTES:

1. ALL NAILING PER PBS-100S
2. FOAM EDGE OF SIPS WILL BE RECESSED AT FACTORY TO RECEIVE LUMBER PER SIP SHOP DRAWINGS.
3. FUR OUT EACH SIDE OF HEADER AFTER INSTALLATION.

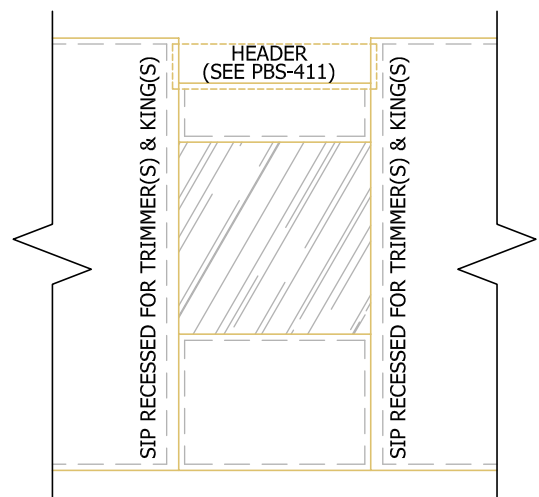

Rev: 9/19/2022

PBS-407

**HEADER AT TOP OF SIP WALL
ASSEMBLY SEQUENCE**



STEP #1:

1. PRE-DRILL ELECTRICAL CHASES PER PBS-106.
2. INSTALL KINGS, TRIMMERS, & NAILERS INTO SIP USING (2) 3/8" BEADS OF SEALANT PER PBS-103 AT ALL INTERFACES (LUMBER TO LUMBER AND LUMBER TO SIP).
3. ASSEMBLE SIPS ON THE GROUND AND LIFT INTO PLACE OR ASSEMBLE VERTICALLY, ONE PIECE AT A TIME.

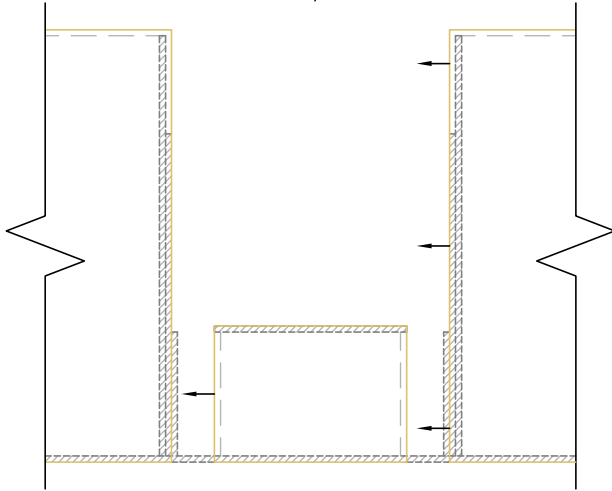

STEP #2:

1. CUT HEADER TO LENGTH FROM FACE OF KING TO FACE OF KING. (SEE PBS-411 FOR ASSEMBLIES).
2. DROP HEADER IN FROM ABOVE.
3. INSTALL ASSEMBLED BEARING PLATE TO TOP OF HEADER PER PBS-406.

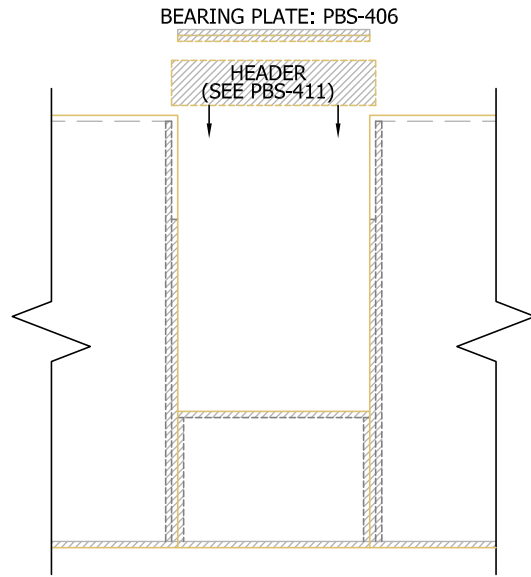

STEP #3:

1. DROP FILLER SIP FROM ABOVE.
2. INSTALL CONTINUOUS TOP PLATE ACROSS SIP JOINTS.

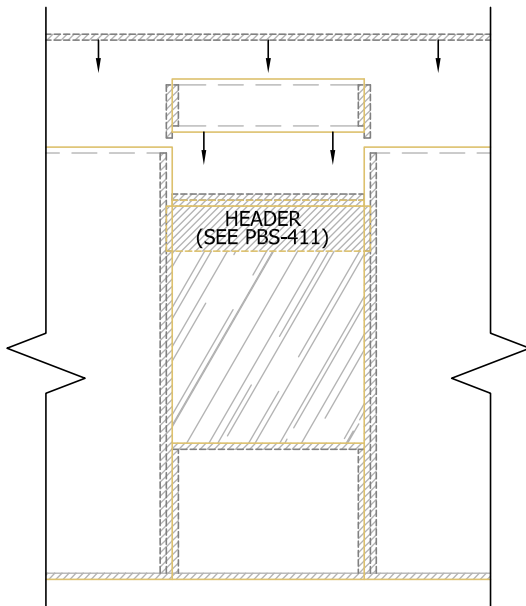

N.T.S.

NOTES:

1. ALL NAILING PER PBS-100S
2. FOAM EDGE OF SIPS WILL BE RECESSED AT FACTORY TO RECEIVE LUMBER PER SIP SHOP DRAWINGS.
3. FUR OUT EACH SIDE OF HEADER AFTER INSTALLATION.

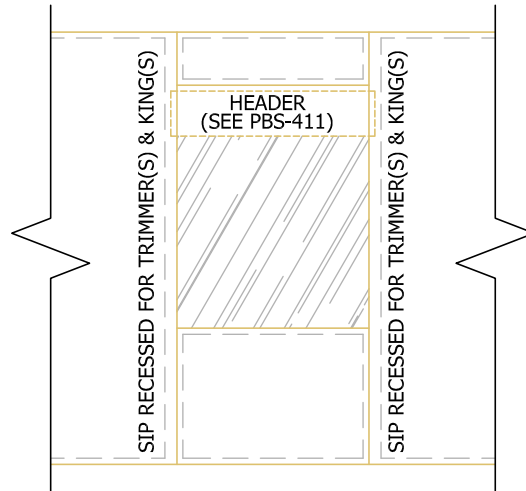

Rev: 9/19/2022

PBS-408

**HEADER AT TOP OF OPENING
ASSEMBLY SEQUENCE**



STEP #1:

1. PRE-DRILL ELECTRICAL CHASES PER PBS-106.
2. INSTALL KINGS, TRIMMERS, & NAILERS INTO SIP USING (2) 3/8" BEADS OF SEALANT PER PBS-103 AT ALL INTERFACES (LUMBER TO LUMBER AND LUMBER TO SIP).
3. ASSEMBLE SIPS ON THE GROUND AND LIFT INTO PLACE OR ASSEMBLE VERTICALLY, ONE PIECE AT A TIME.

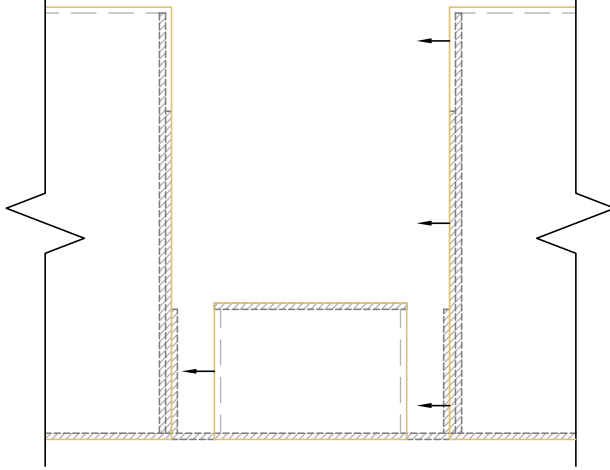

STEP #2:

1. CUT HEADER TO LENGTH FROM FACE OF KING TO FACE OF KING. (SEE PBS-411 FOR ASSEMBLIES).
2. DROP HEADER IN FROM ABOVE.

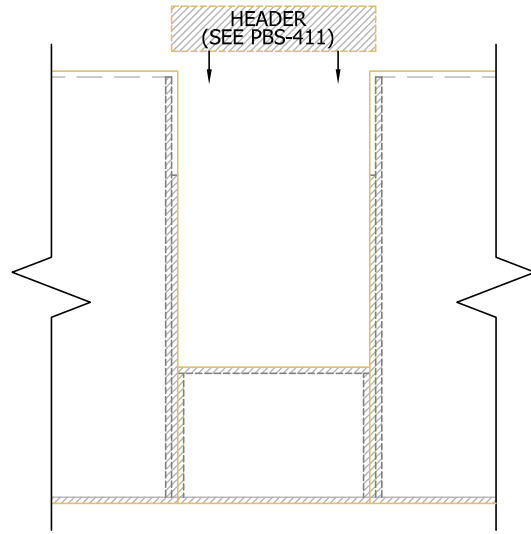

STEP #3:

1. DROP FILLER SIP FROM ABOVE.
2. INSTALL CONTINUOUS TOP PLATE ACROSS SIP JOINTS.

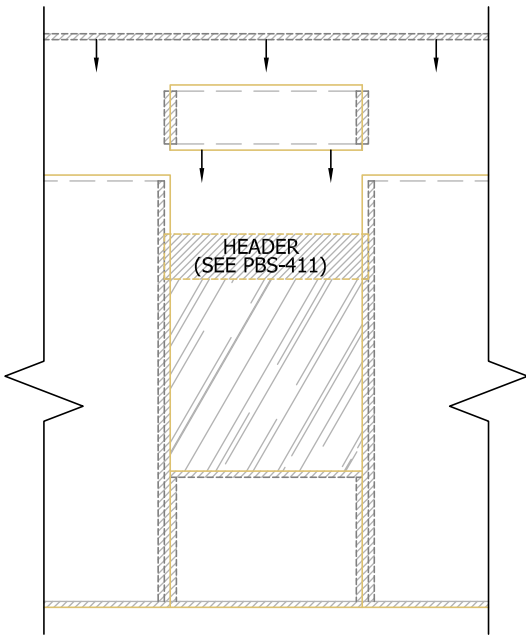

N.T.S.

NOTES:

1. *THIS DETAIL DOES NOT ALLOW FOR SIP FACING BEARING FOR SIP ABOVE HEADER PER PBS-406. LOADS MUST BE TRANSFERRED FROM FACING INTO HEADERS BY FACING NAILS ALONE. THIS CONDITION MUST BE ENGINEERED.
2. ALL NAILING PER PBS-100S
3. FOAM EDGE OF SIPS WILL BE RECESSED AT FACTORY TO RECEIVE LUMBER PER SIP SHOP DRAWINGS.
4. FUR OUT EACH SIDE OF HEADER AFTER INSTALLATION.

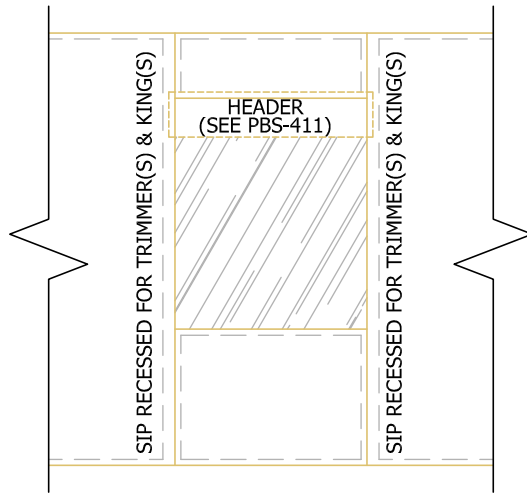

Rev: 9/19/2022

PBS-409

**HEADER AT TOP OF OPENING
LIMITED BEARING* ASSEMBLY SEQUENCE**



NOTES:

1. THIS DETAIL IS USEFUL IN SITUATIONS WHERE THE SILL AND FILLER SIPs ARE TALLER THAN THE OPENING BY REPLACING 2X NAILER LUMBER WITH BLOCK SPLINES, THEREBY REDUCING THERMAL BRIDGING.
2. ALL NAILING PER PBS-100S
3. USE (2) 3/8" BEADS OF SEALANT PER PBS-103 AT ALL INTERFACES (LUMBER TO LUMBER AND LUMBER TO SIP).
4. FOAM EDGE OF SIPs WILL BE RECESSED AT FACTORY TO RECEIVE LUMBER PER SIP SHOP DRAWINGS.
5. FUR OUT EACH SIDE OF HEADER AFTER INSTALLATION.

STEP #1:

1. PRE-DRILL ELECTRICAL CHASES PER PBS-106.
2. INSTALL KINGS & TRIMMERS INTO SIP SO THAT 1 1/2" OF OSB FACING REMAINS TO RECEIVE SILL AND FILLER SIPs.
3. INSTALL 2X TO TOP OF SILL AND BOTTOM OF FILLER SIP SO THAT 2X EXTENDS 1 1/2" PAST EDGE OF SIP FACING.
4. INSTALL BLOCK SPLINE IN VERTICAL EDGES OF SILL AND FILLER SIP SO THAT BLOCK SPLINE IS FLUSH TO FOAM.
5. ASSEMBLE SIPs ON THE GROUND AND LIFT INTO PLACE OR ASSEMBLE VERTICALLY, ONE PIECE AT A TIME.

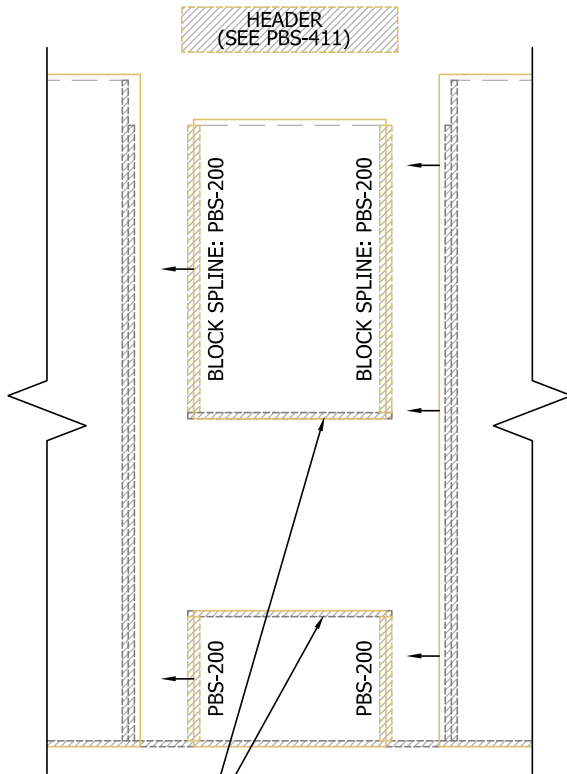

(1) CONTINUOUS
2X EXTENDS PAST
SIP FACINGS.

N.T.S.

STEP #2:

1. CUT HEADER TO LENGTH FROM FACE OF KING TO FACE OF KING. (SEE PBS-411 FOR ASSEMBLIES).
2. INSTALL TWO 2X WINDOW BUCK PIECES WITHIN VERTICAL EDGES OF ROUGH OPENING.
3. DROP IN HEADER FROM ABOVE.
4. INSTALL CONTINUOUS TOP PLATE ACROSS HEADER AND SIPs.

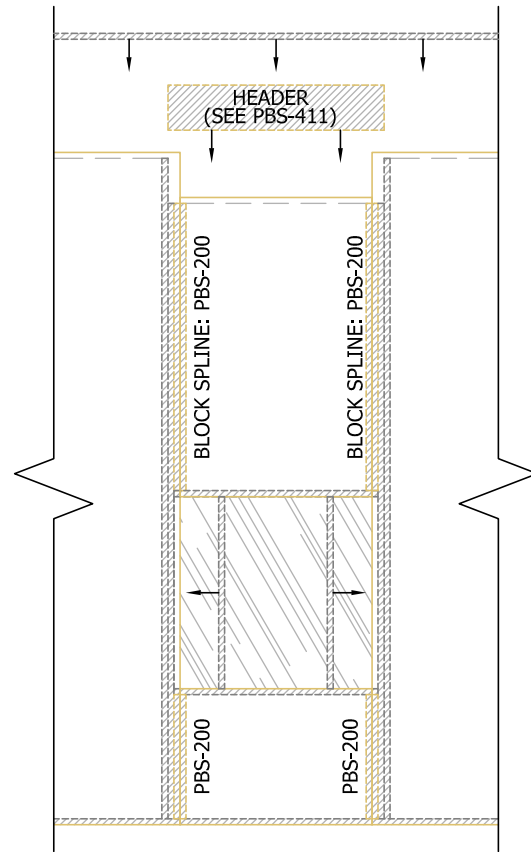

Rev: 9/19/2022

PBS-410

**HEADER AT TOP OF TALL SIP WALL
ASSEMBLY SEQUENCE**



SIP HEADER: SIP AS A STRUCTURAL HEADER.
SEE PBS-407 OR PBS-408 FOR ASSEMBLY SEQUENCE.

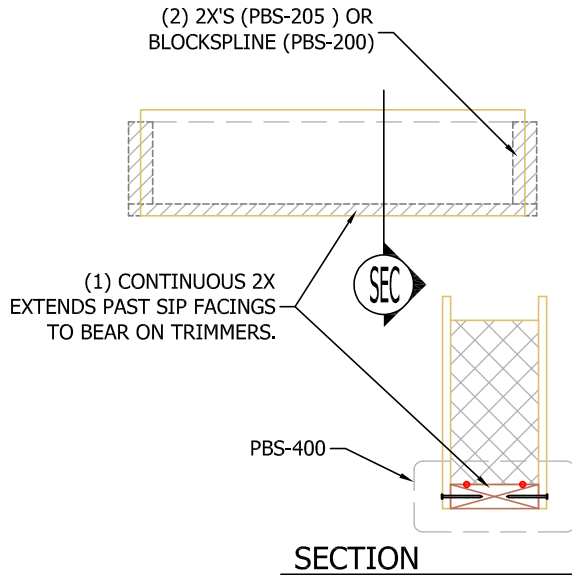

IHDR-1 PLY: INSULATED HEADER (1) PLY LVL.
SEE PBS-407 OR PBS-408 FOR ASSEMBLY SEQUENCE.

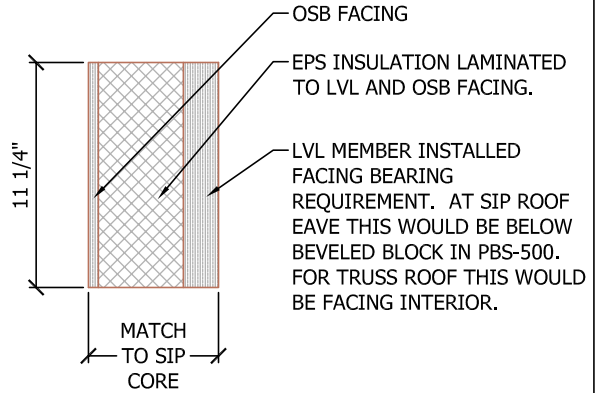

IHDR-2 PLY: INSULATED HEADER (2) PLY LVL.
SEE PBS-407 OR PBS-408 FOR ASSEMBLY SEQUENCE.

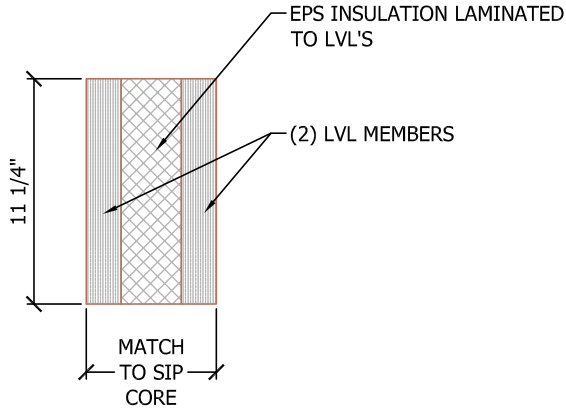

HBO: HEADER BY OTHERS.
SEE PBS-407 OR PBS-408 FOR ASSEMBLY SEQUENCE.

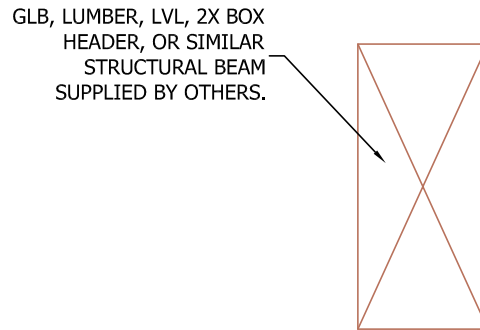

N.T.S.

Rev: 12/10/2021

PBS-411

HEADER ASSEMBLIES



NOTES:

1. ALL NAILING PER PBS-100S
2. USE (2) 3/8" BEADS OF SEALANT PER PBS-103.
3. FOAM EDGE OF SIPS WILL BE RECESSED AT FACTORY TO RECEIVE LUMBER PER SIP SHOP DRAWINGS.

STEP #1:
INSTALL OPENING TOP AND BOTTOM 2X MEMBERS FLUSH TO FOAM.

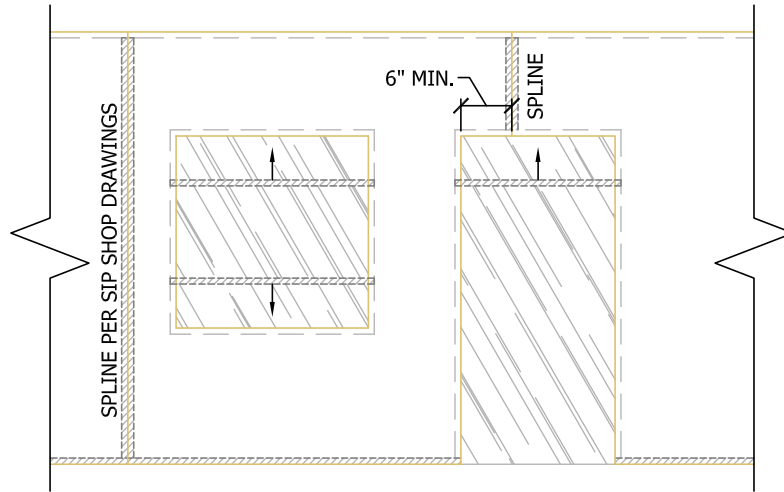

STEP #2:

1. PRE-DRILL ELECTRICAL CHASES PER PBS-106
2. INSTALL OPENING VERTICAL 2X MEMBERS FLUSH TO LUMBER PLATES AT TOP AND BOTTOM OF OPENING.
3. INSTALL CONTINUOUS TOP PLATE ACROSS SIP JOINTS.

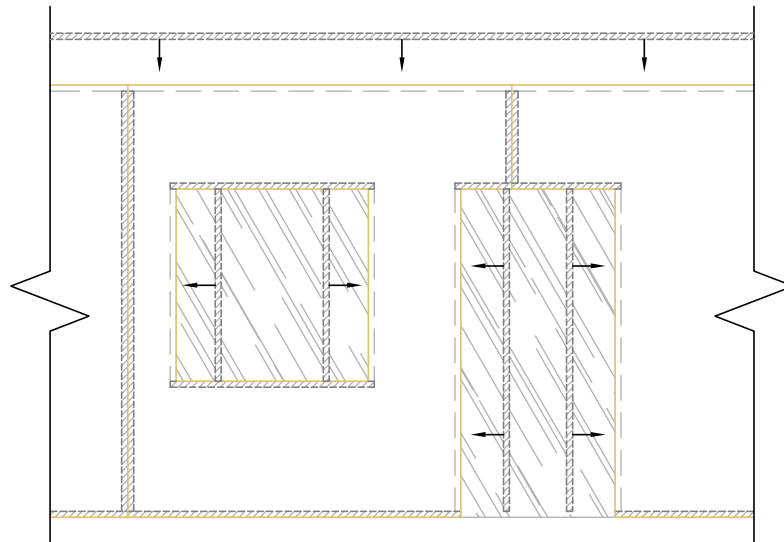

N.T.S.

Rev: 8/11/2022

PBS-412

FACTORY CUT OPENINGS



NOTES:

1. ALL NAILING PER PBS-100S
2. USE (2) 3/8" BEADS OF SEALANT PER PBS-103 AT ALL INTERFACES (LUMBER TO LUMBER AND LUMBER TO SIP).
3. FOAM EDGE OF SIPS WILL BE RECESSED AT FACTORY TO RECEIVE LUMBER PER SIP SHOP DRAWINGS.

STEP #1:

1. ASSEMBLE KINGS, TRIMMERS, NAILERS, SILL, FILLER SIP, AND HEADER INTO ONE PIECE.
2. PRE-DRILL ELECTRICAL CHASES PER PBS-106.
3. INSTALL ASSEMBLY INTO ADJACENT SIPS.

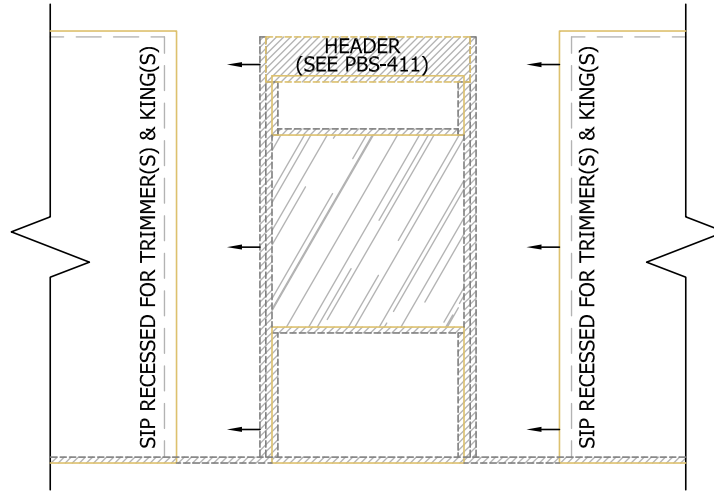

STEP #2:

INSTALL CONTINUOUS TOP PLATE ACROSS SIP JOINTS.

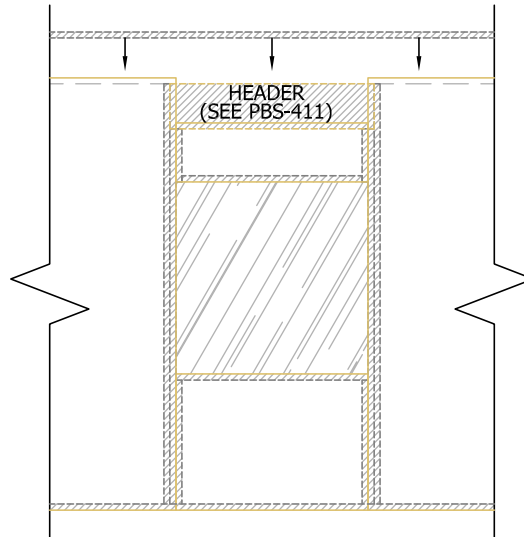

N.T.S.

Rev: 9/19/2022

PBS-413

**RTA OPENING
ASSEMBLY SEQUENCE**



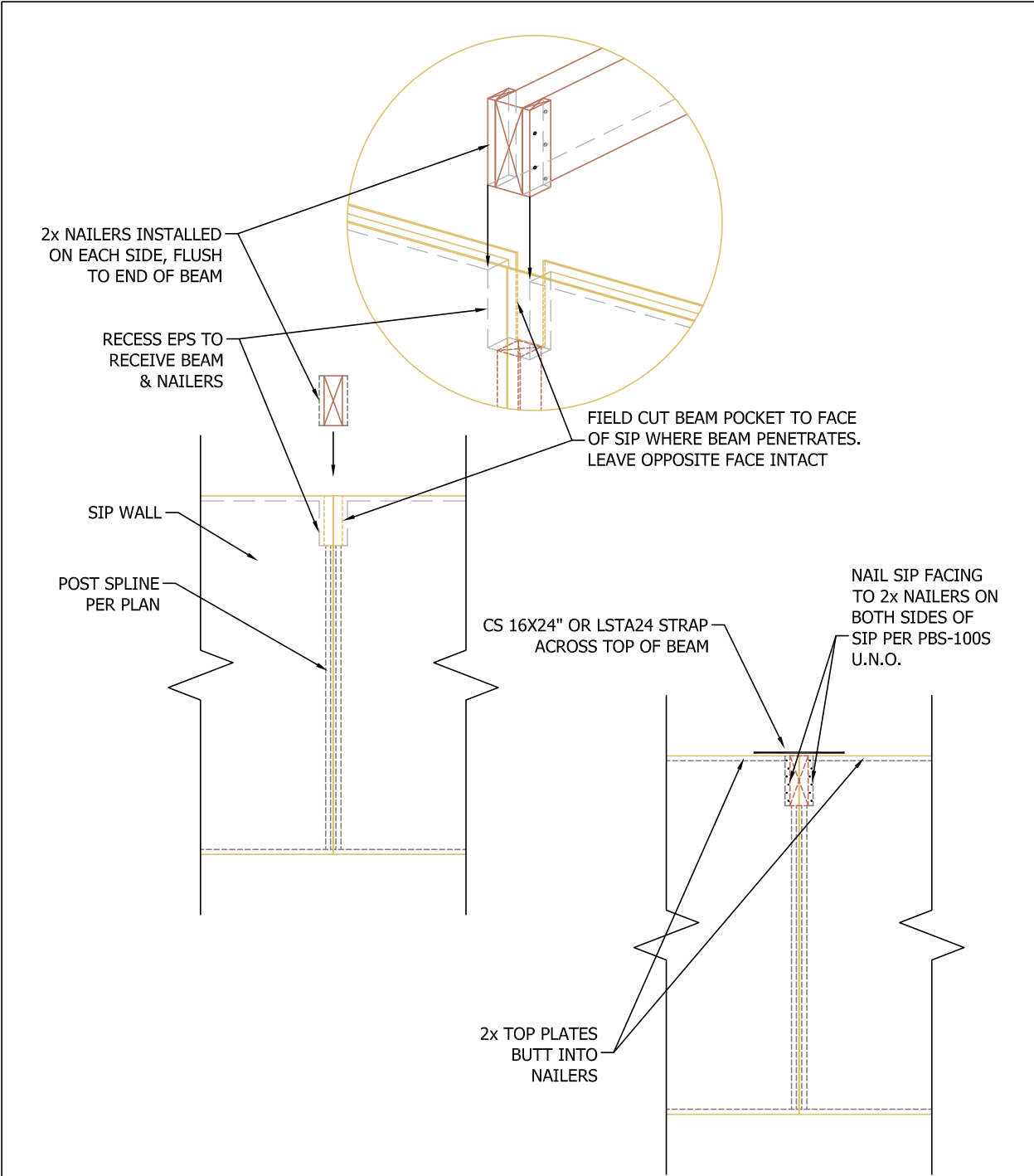

N.T.S.

Rev: 9/19/2022

PBS-414

SIP BEAM POCKET AT TOP OF WALL WITH POST



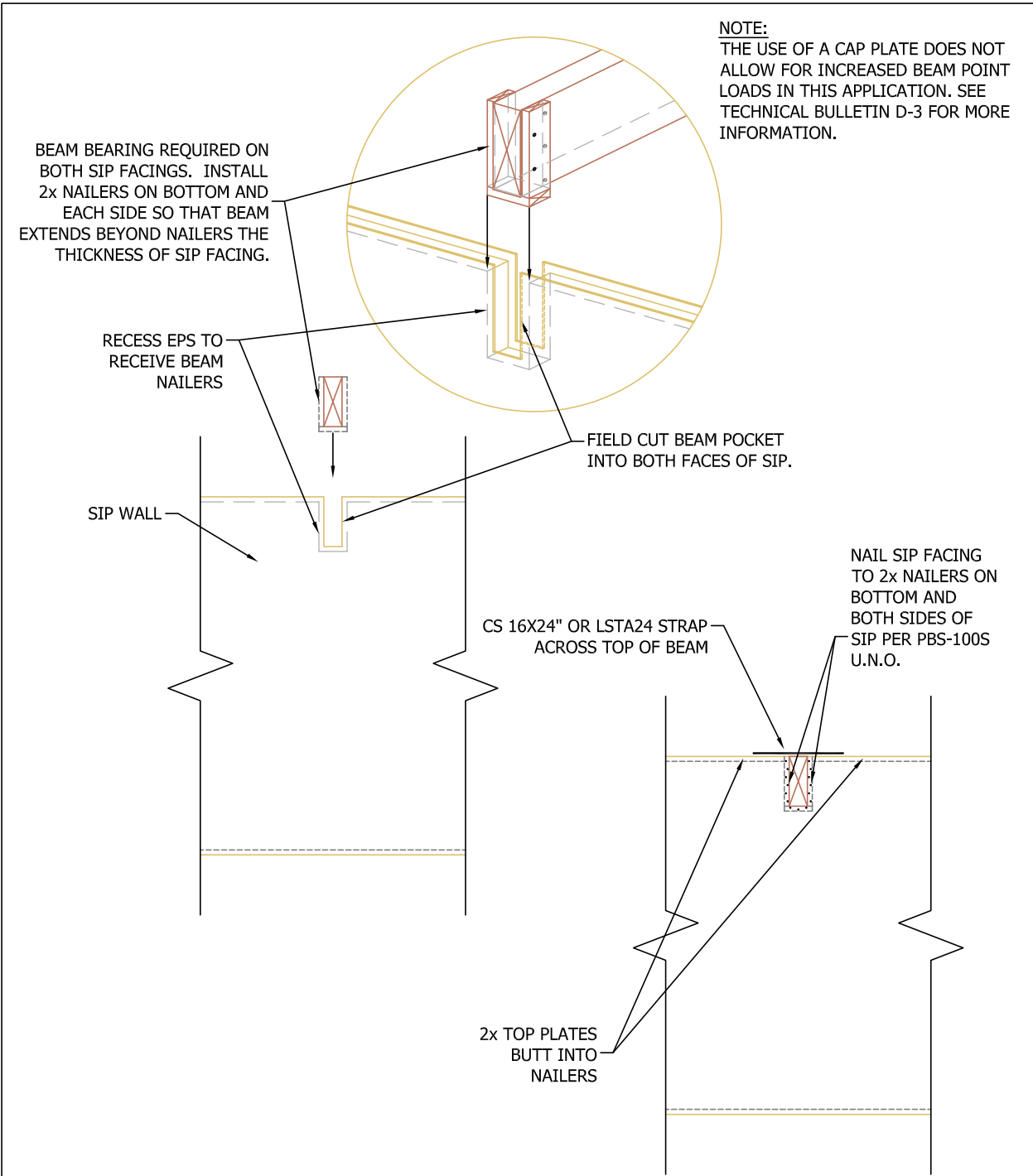

N.T.S.

Rev: 9/19/2022

<p>PBS-415</p>	<p>SIP BEAM POCKET AT TOP OF WALL WITHOUT POST</p>	
----------------	--	---

NOTE:
SEE PBS-600 FOR ALTERNATE SIP BEARING CONDITIONS

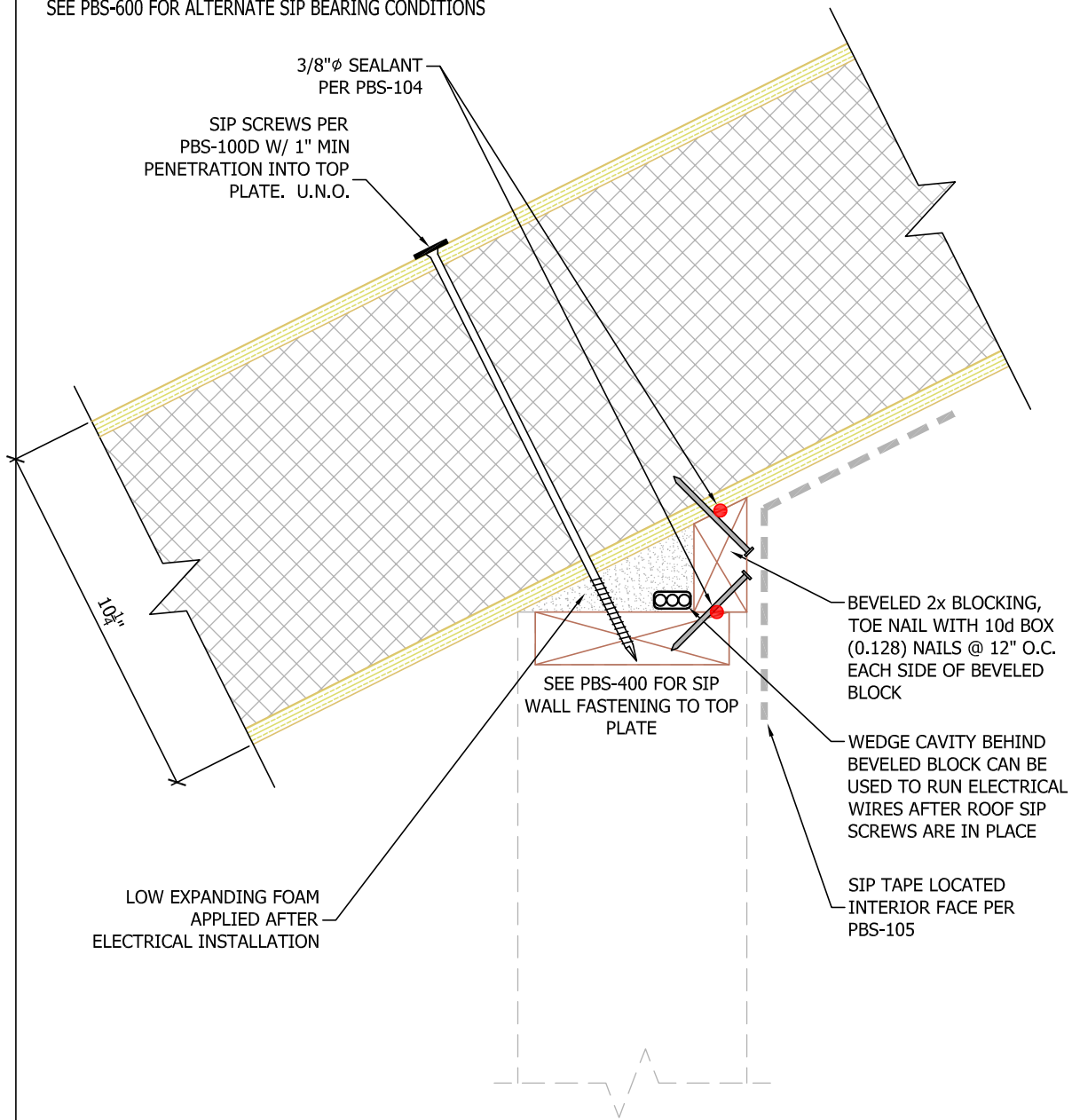

N.T.S.

Rev: 9/19/2022

PBS-500

SIP WALL TO ROOF
BEVELED BLOCK



NOTE:
SEE PBS-600 FOR ALTERNATE SIP BEARING CONDITIONS

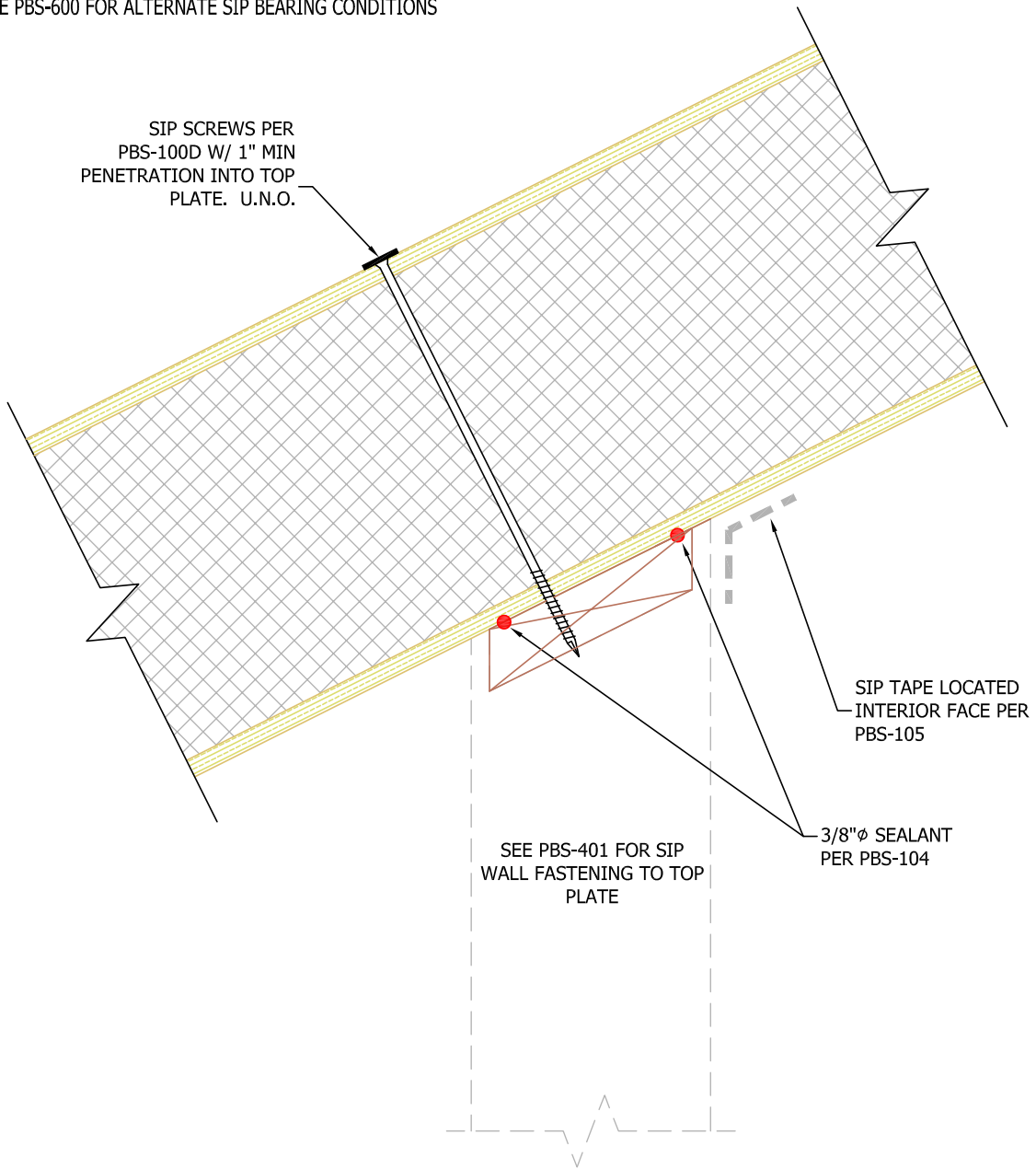

N.T.S.

Rev: 5/24/2022

PBS-501

SIP WALL TO ROOF
BEVELED TOP OF WALL



NOTE:
SEE PBS-600 FOR ALTERNATE SIP BEARING CONDITIONS

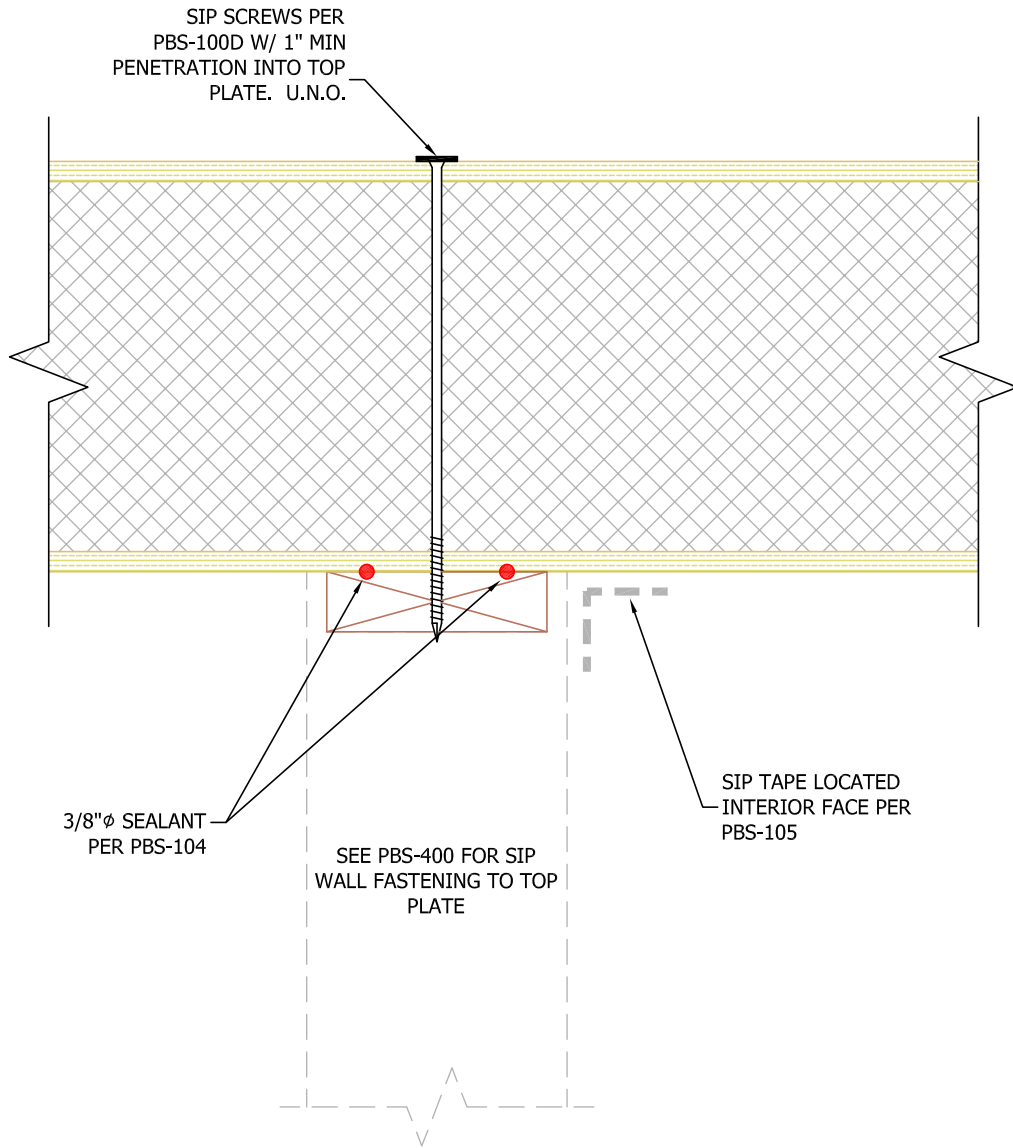

N.T.S.

Rev: 5/24/2022

PBS-502

SIP WALL TO ROOF
GABLE OVERHANG



NOTE:

SEE PBS-600 FOR ALTERNATE SIP BEARING CONDITIONS

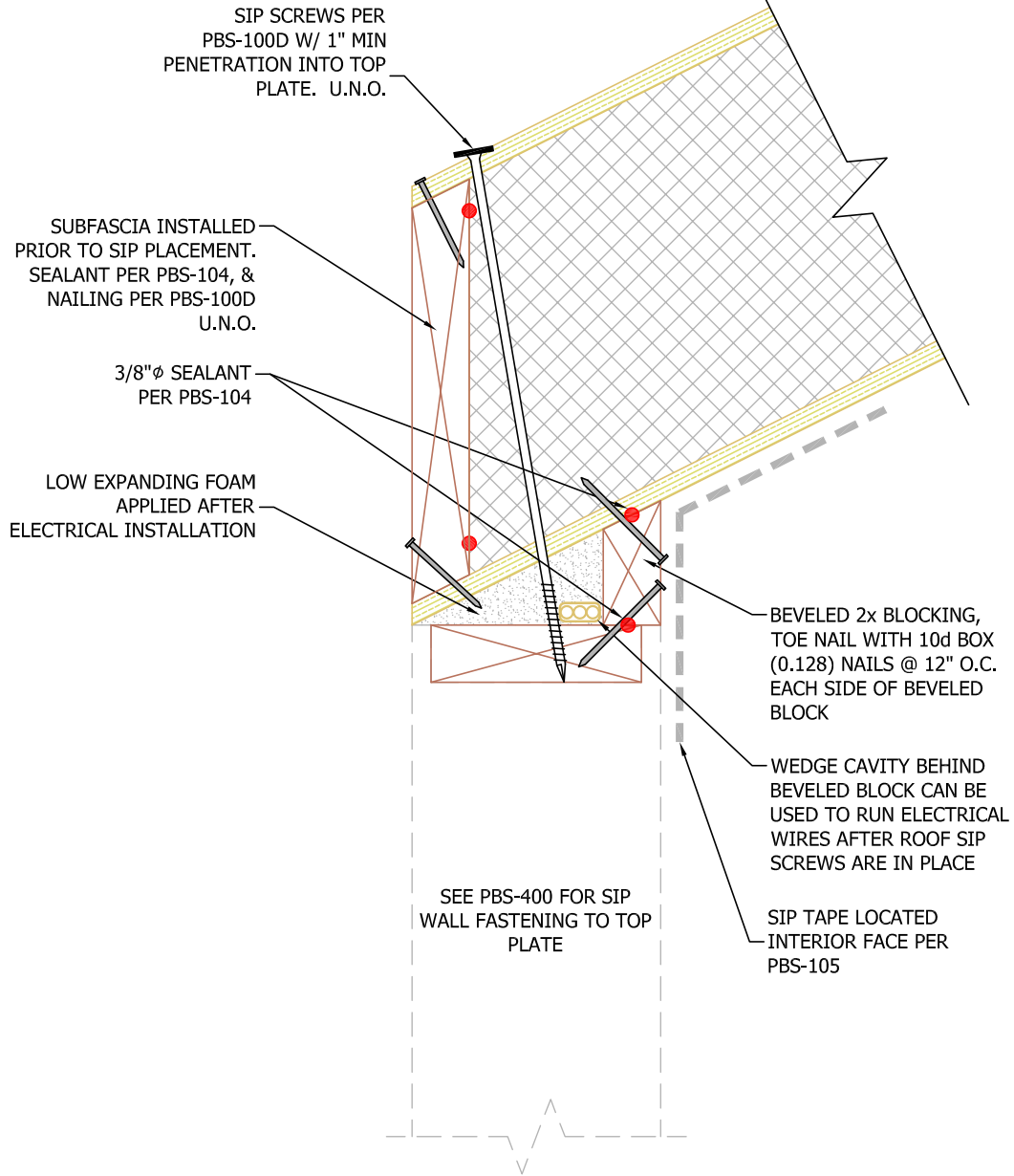

N.T.S.

Rev: 9/19/2022

PBS-503

SIP WALL TO ROOF, NO OVERHANG
BEVELED BLOCK



NOTE:

SEE PBS-600 FOR ALTERNATE SIP BEARING CONDITIONS

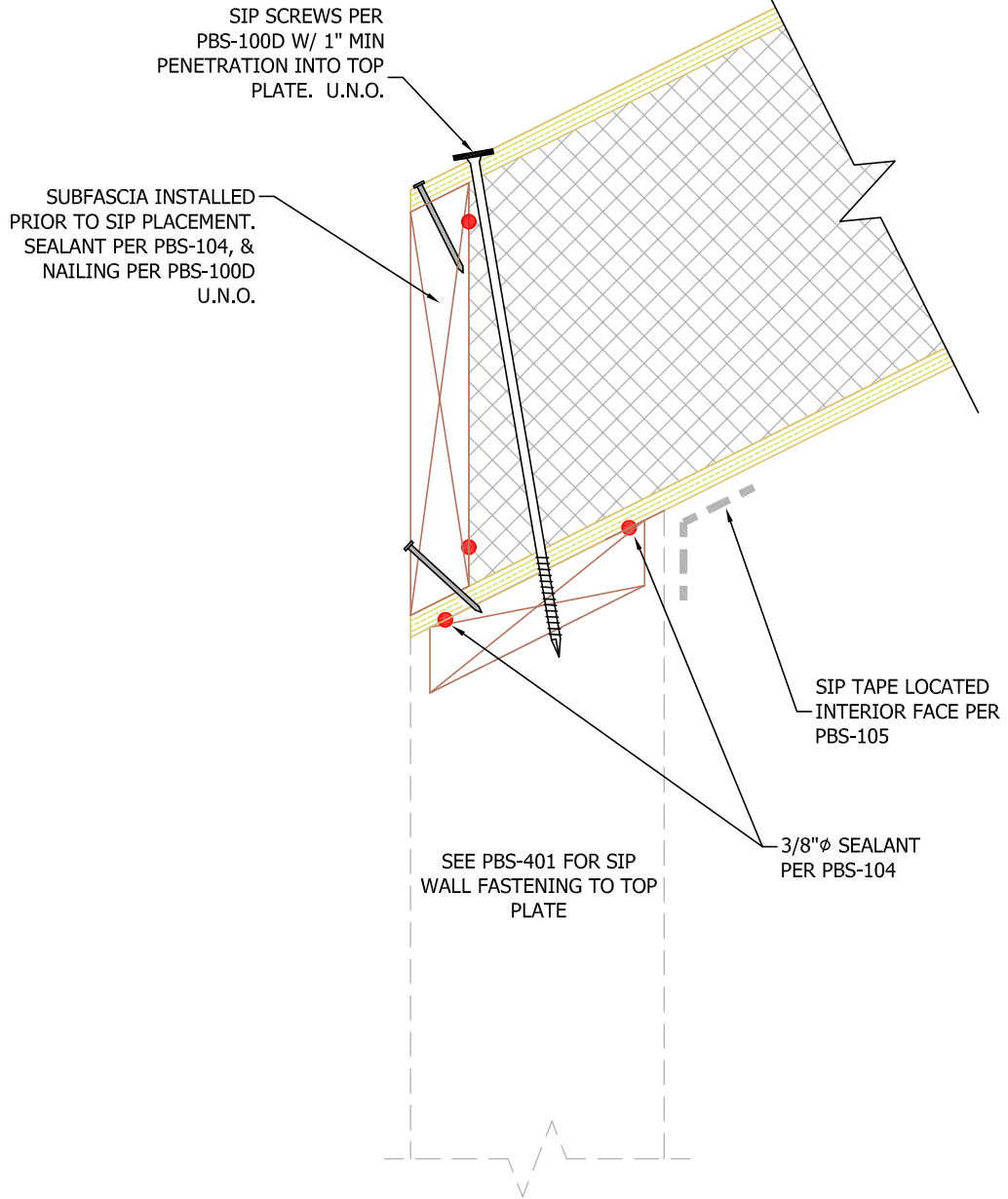

N.T.S.

Rev: 7/19/2022

PBS-504

SIP WALL TO ROOF, NO OVERHANG
BEVELED TOP OF WALL



NOTE:
SEE PBS-600 FOR ALTERNATE SIP BEARING CONDITIONS

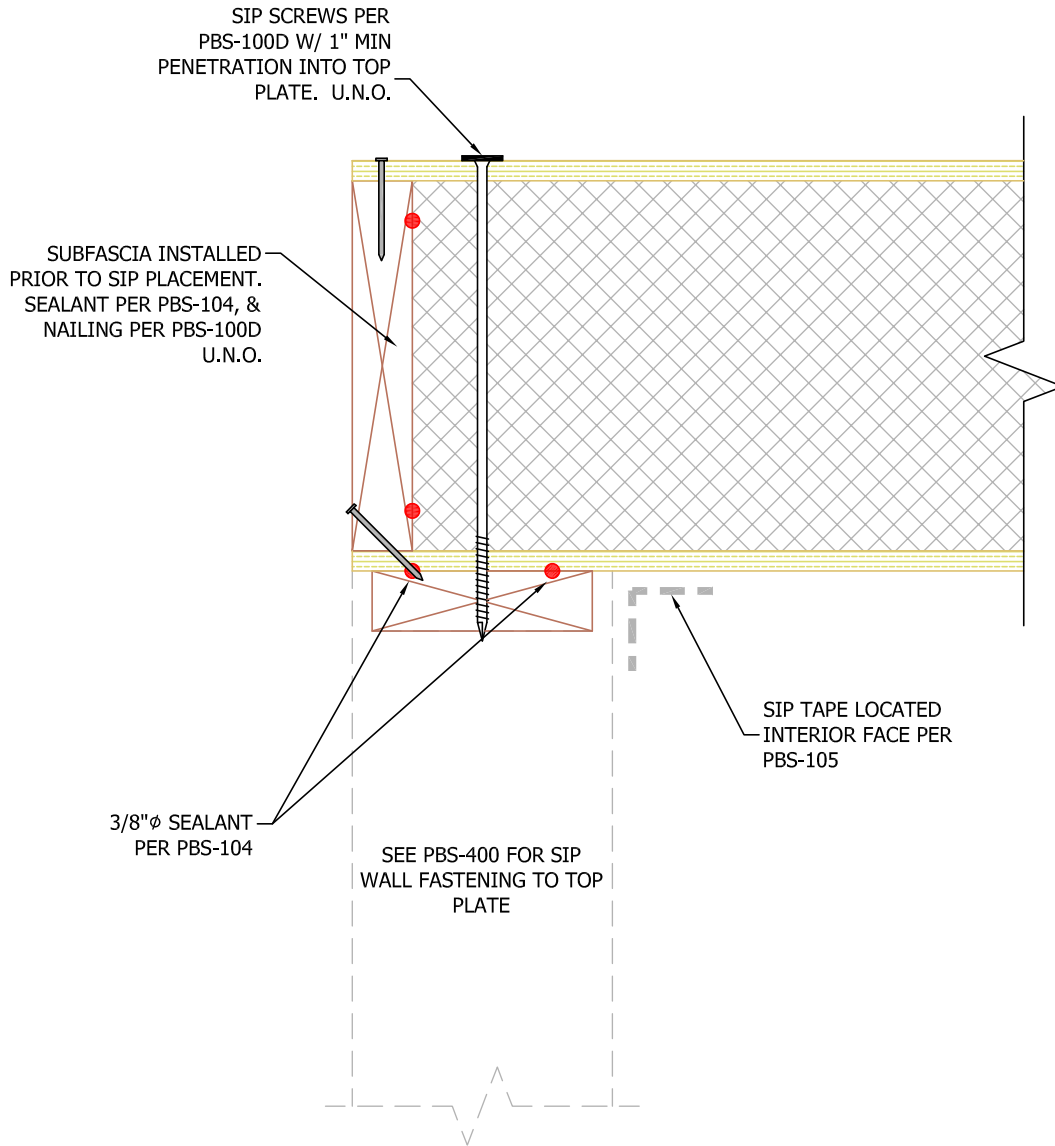

N.T.S.

Rev: 7/19/2022

PBS-505

**SIP WALL TO ROOF GABLE
NO OVERHANG**



OPTION A:

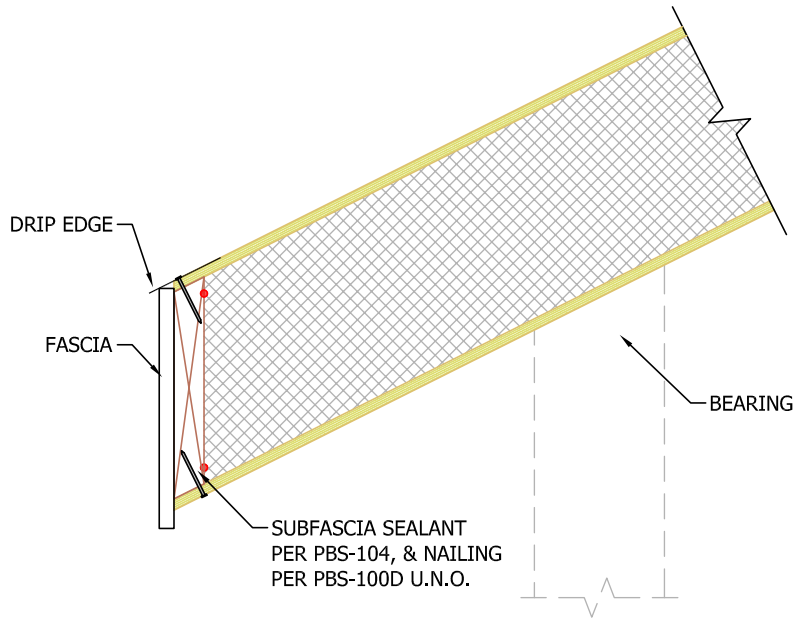

OPTION B:

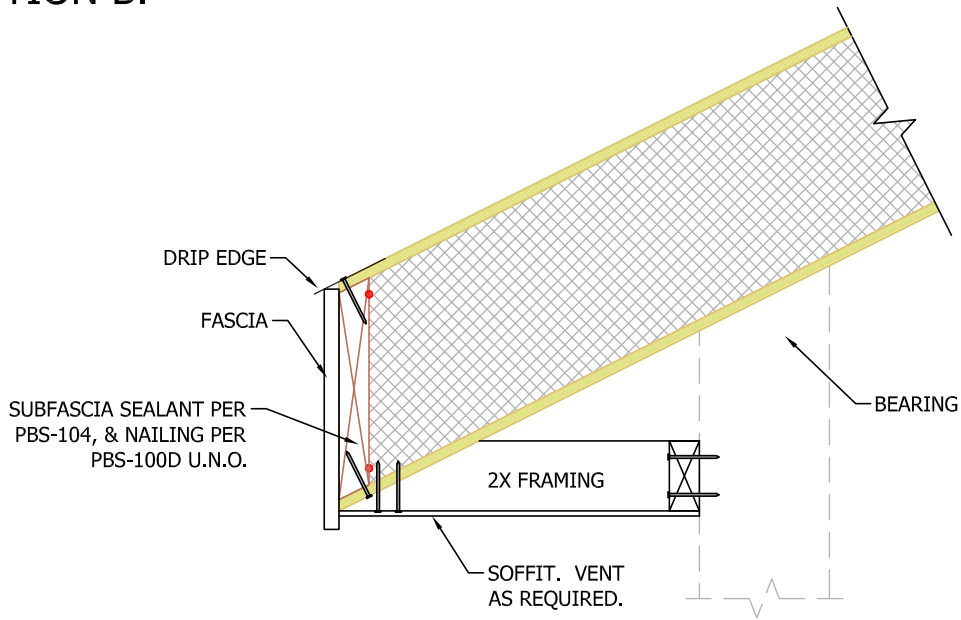

N.T.S.

Rev: 9/19/2022

PBS-506

**SIP EAVE
PLUMB CUT SIP**



OPTION A:

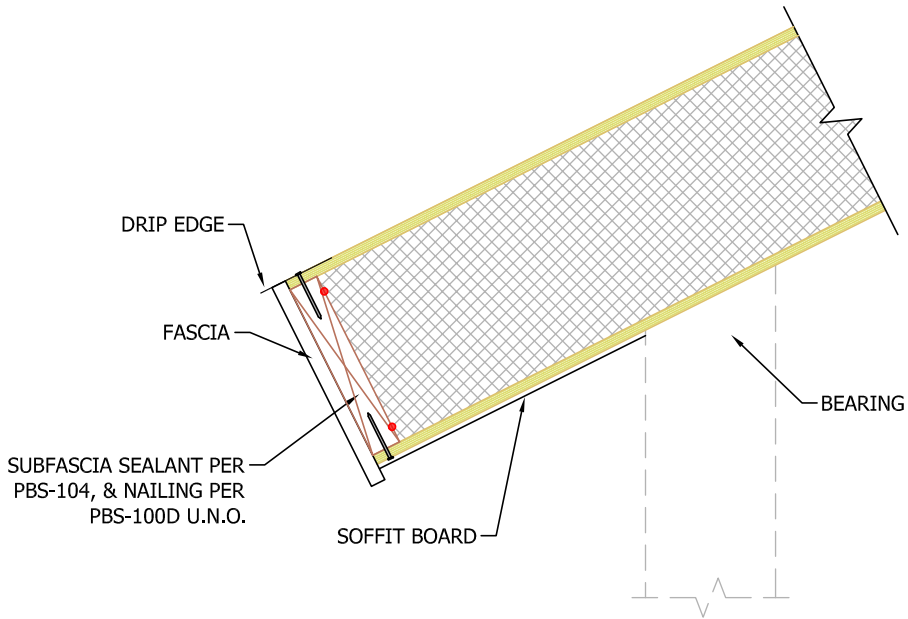

OPTION B:

BEVELED BLOCK ATTACHED TO SIP SUBFASCIA TO GENERATE PLUMB CUT EAVE

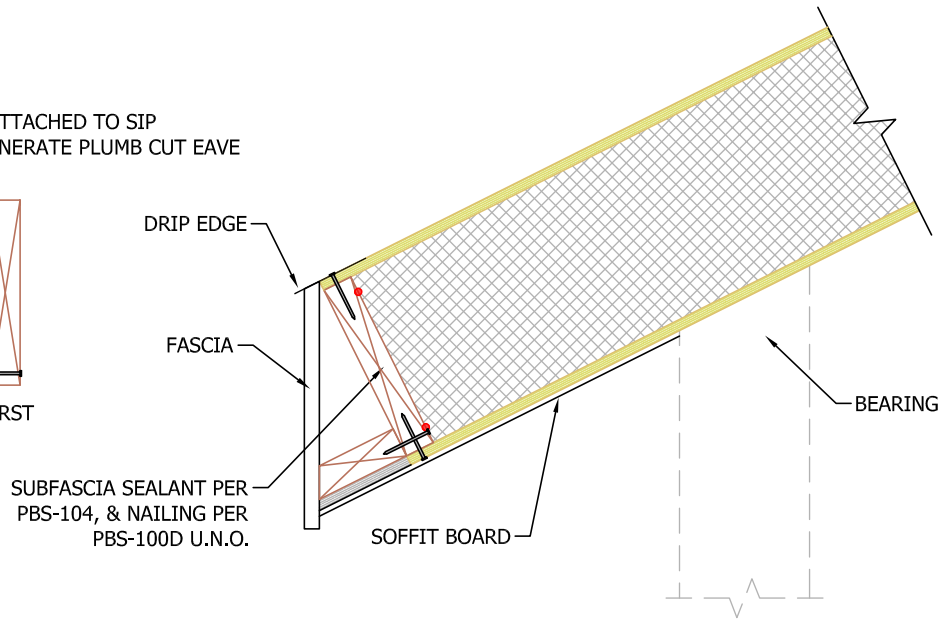
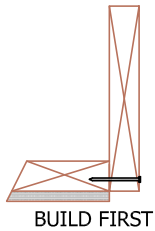

N.T.S.

Rev: 2/16/2023

PBS-507

**SIP EAVE
SQUARE CUT SIP**



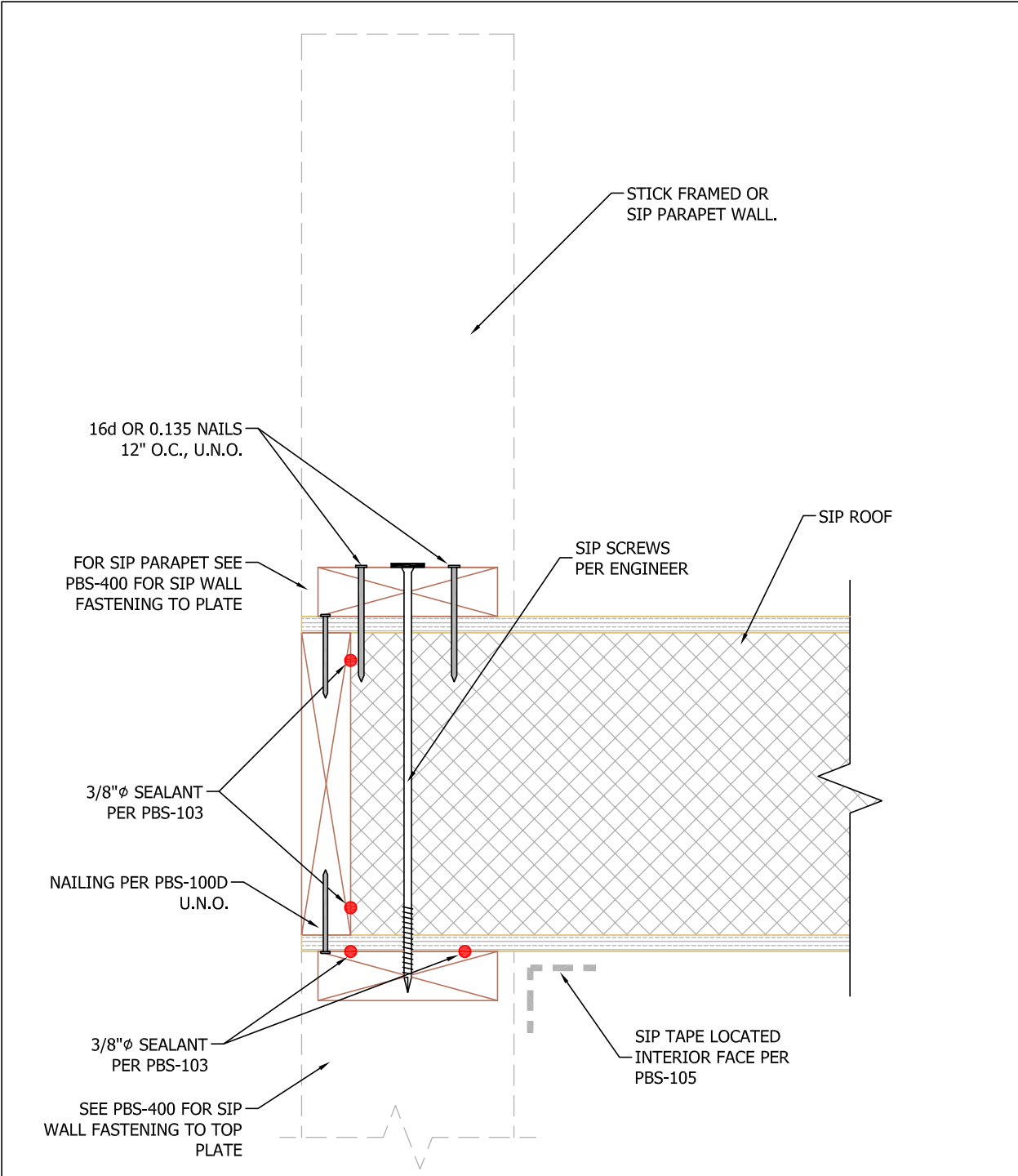

N.T.S.

Rev: 5/24/2022

PBS -508

PARAPET DETAIL



OPTION A:

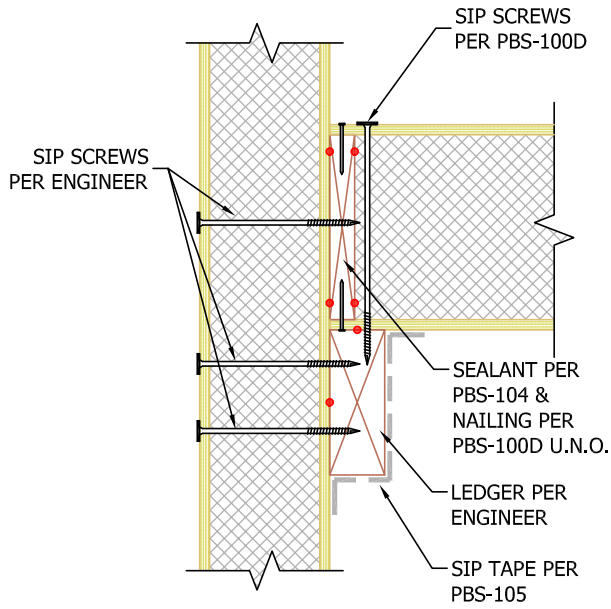

OPTION B:

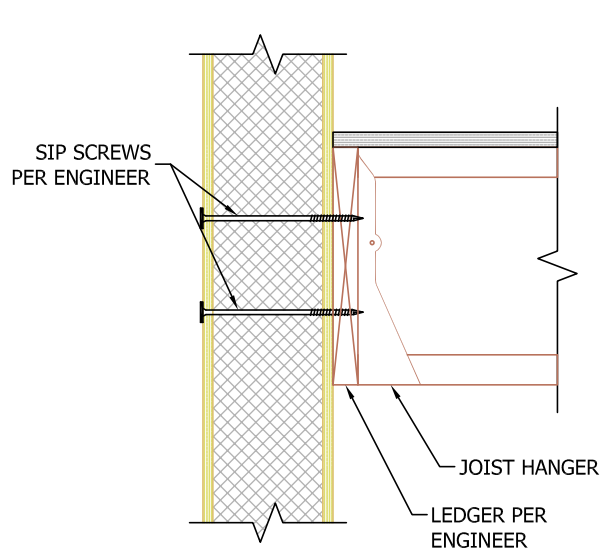

OPTION C:

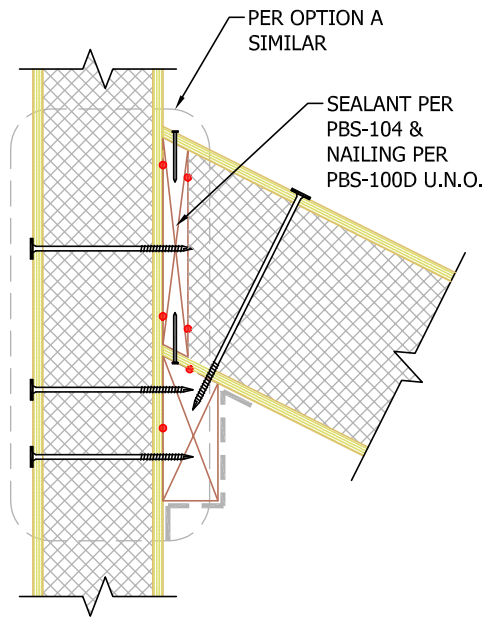

OPTION D:

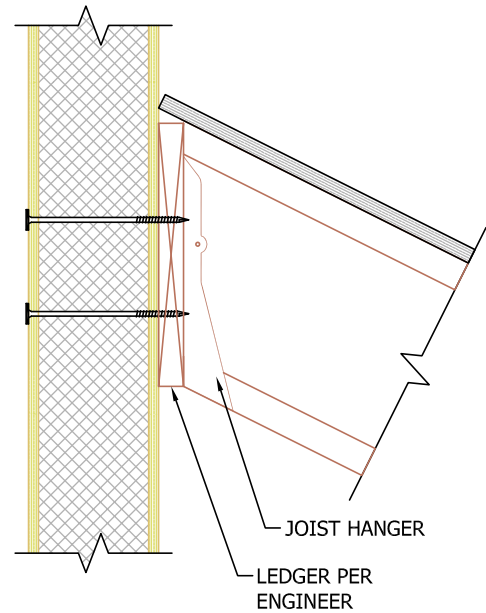

N.T.S.

Rev: 9/21/2022

PBS-509A-D

LEDGER DETAILS
SIP WALL



OPTION E:

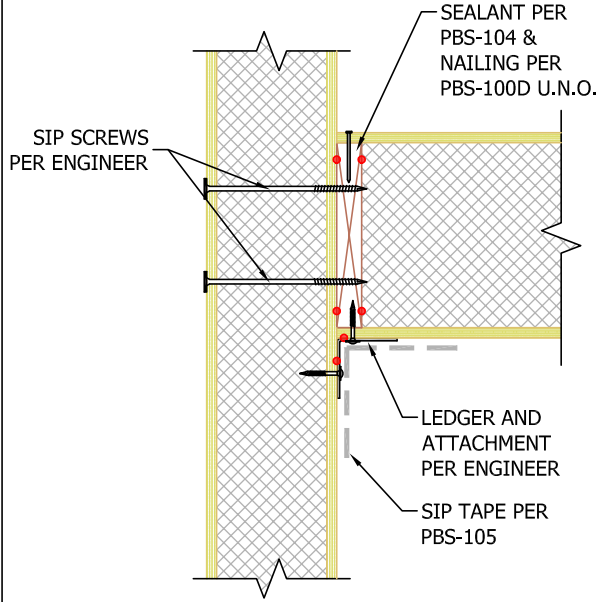

OPTION F:

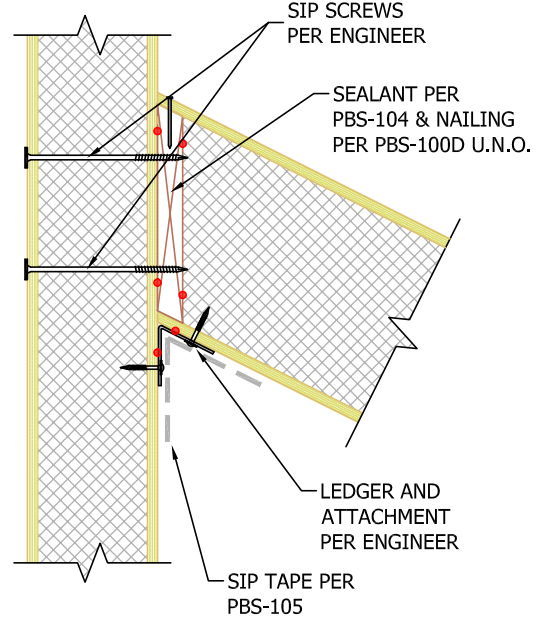

OPTION G:

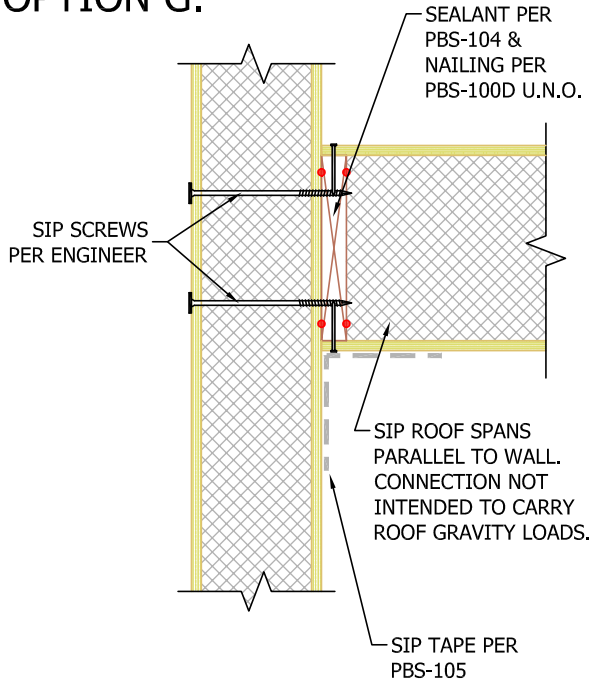

OPTION H:

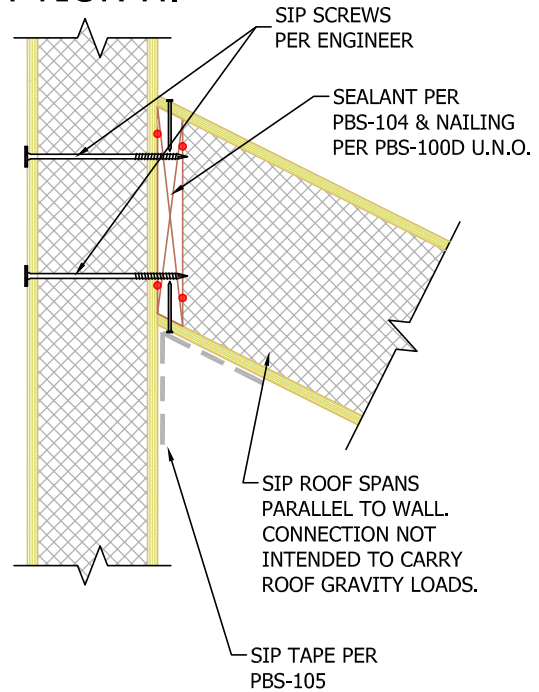

N.T.S.

Rev: 12/10/2021

PBS-509E-H

**LEDGER DETAILS
SIP WALL**



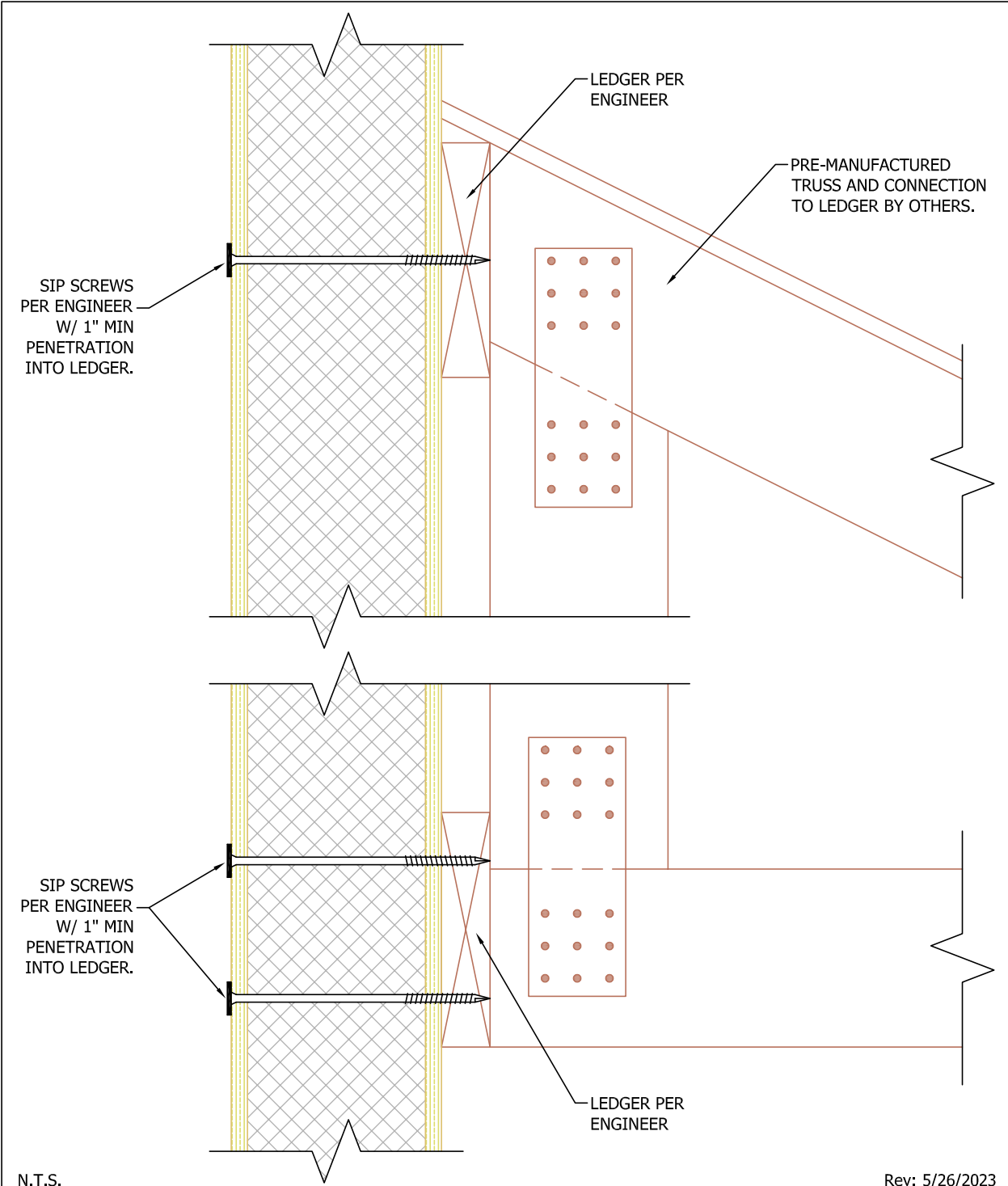

N.T.S.

Rev: 5/26/2023

PBS-509J

LEDGER DETAILS
SIP WALL



OPTION A:

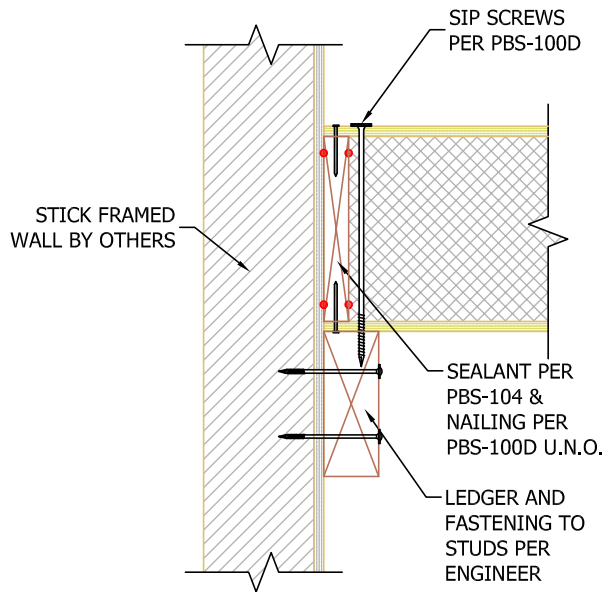

OPTION B:

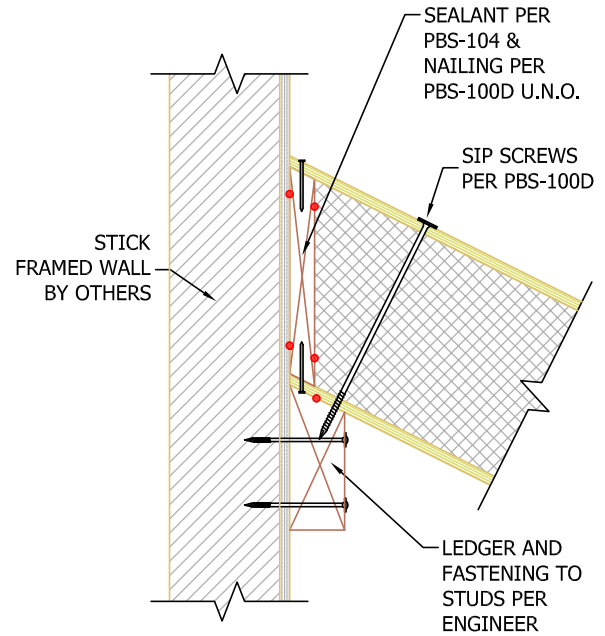

OPTION C:

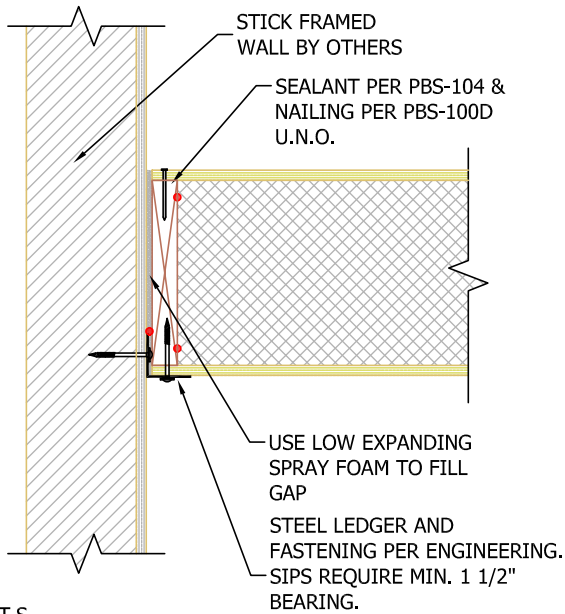

N.T.S.

OPTION D:

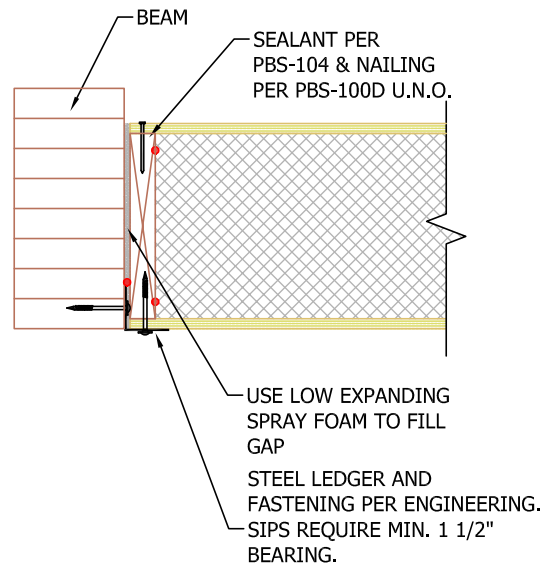

Rev: 9/20/2022

PBS-510

**LEDGER DETAILS
STICK WALL**



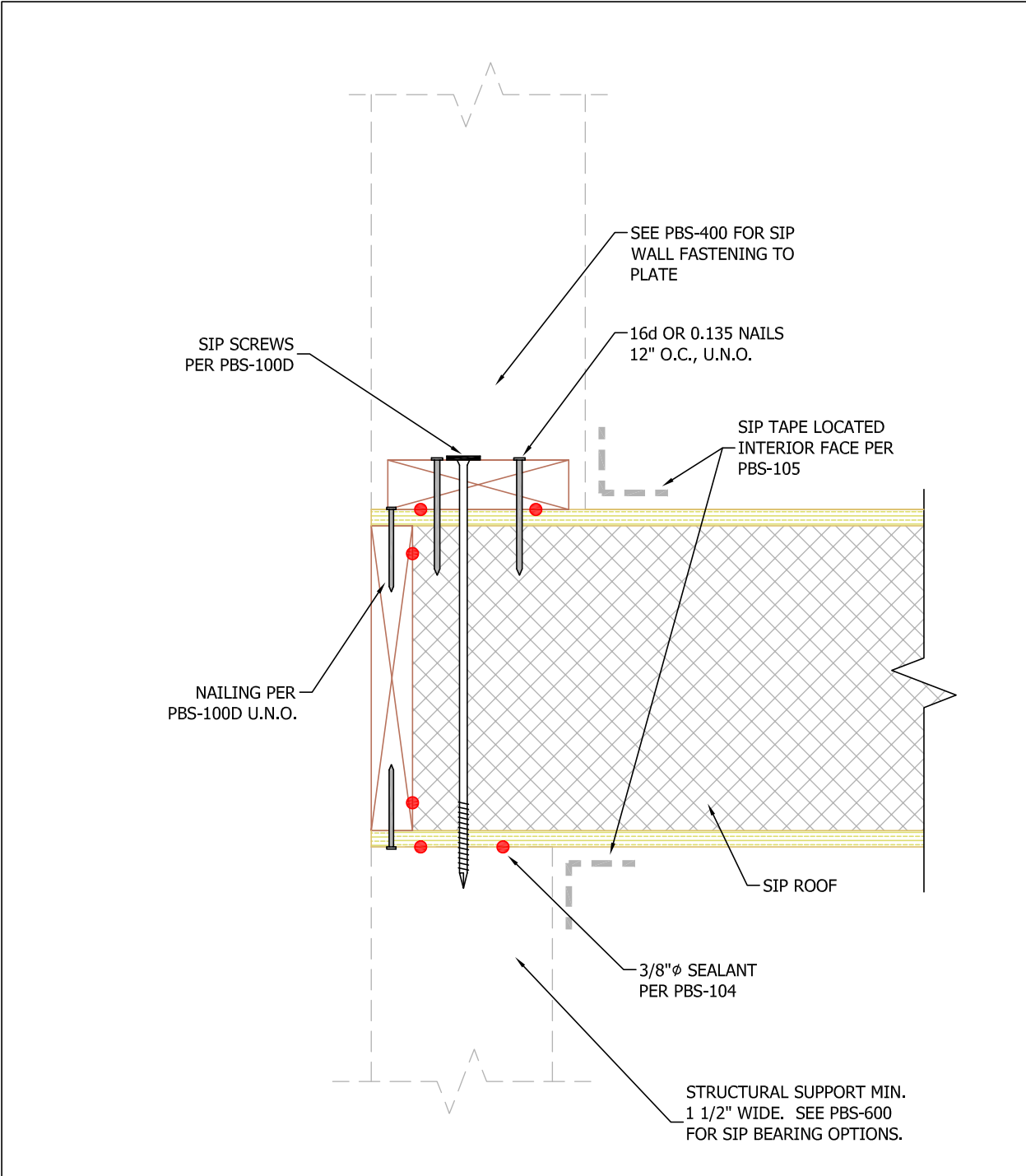

N.T.S.

Rev: 9/19/2022

<p>PBS-511</p>	<p>SIP WALL & ROOF PLATFORM FRAMING PERPENDICULAR INTERSECTION</p>	
----------------	--	--

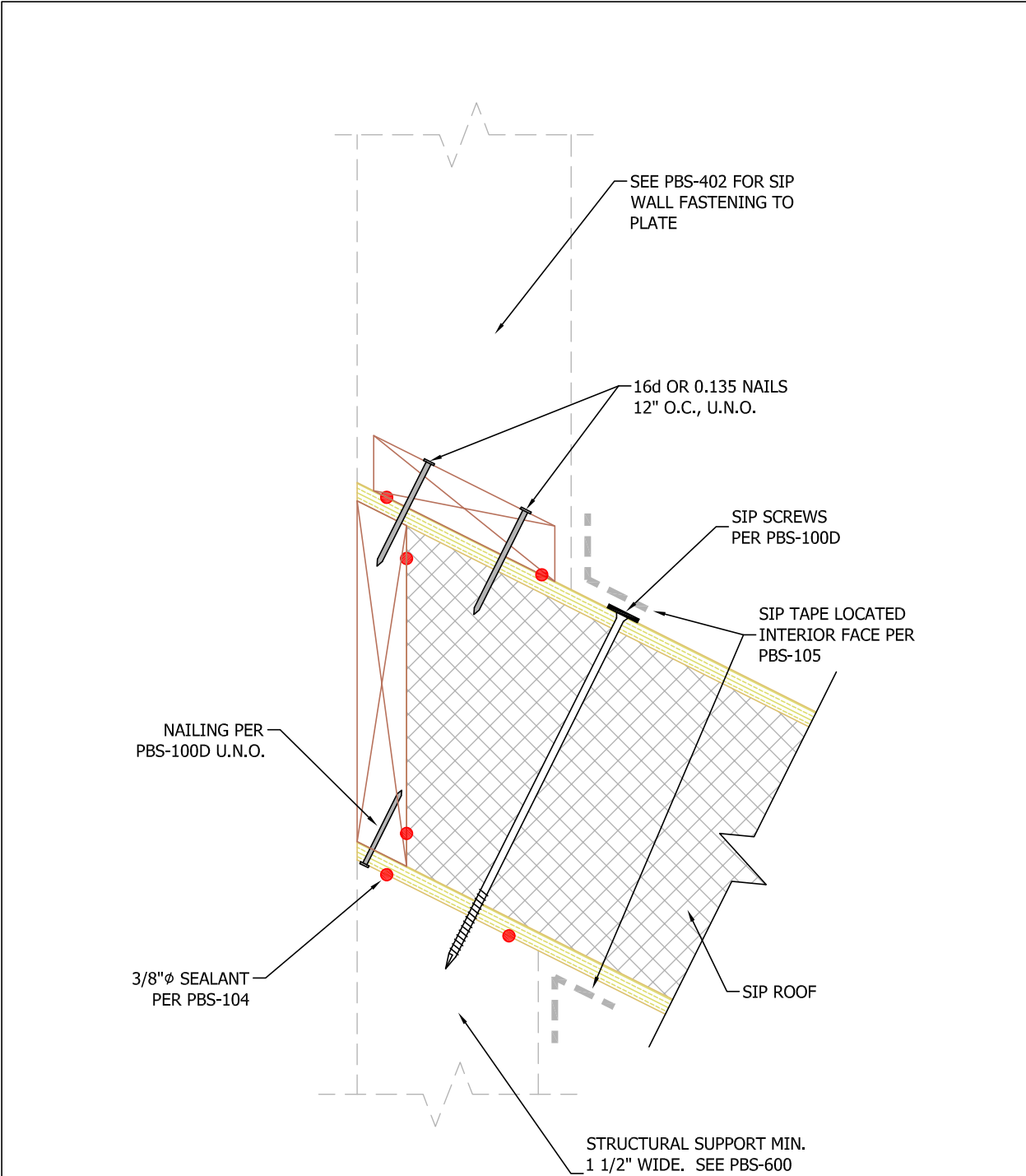

N.T.S.

Rev: 8/4/2022

PBS-512

**SIP WALL & ROOF PLATFORM FRAMING
SLOPED INTERSECTION**



OPTION A:

SIP SCREWS PER
PBS-100D W/ 1" MIN
PENETRATION INTO TOP
PLATE. U.N.O.

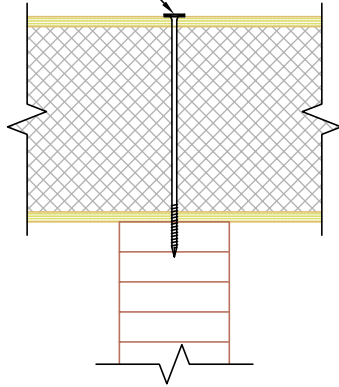

STRUCTURAL SUPPORT TO PROVIDE 1 1/2" MIN.
BEARING FOR SIP

OPTION B:

SIP SCREWS PER
PBS-100D W/ 1" MIN
PENETRATION INTO TOP
PLATE. U.N.O.

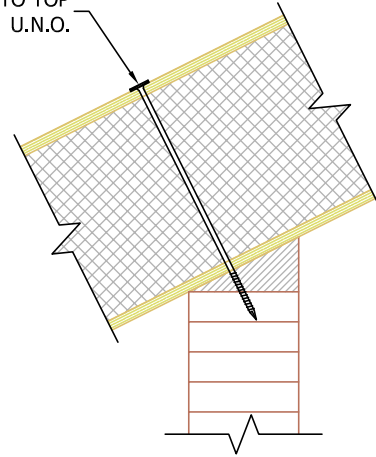

STRUCTURAL SUPPORT TO PROVIDE 1 1/2" MIN.
BEARING FOR SIP

OPTION C:

SIP SCREWS PER
PBS-100D W/ 1" MIN
PENETRATION INTO TOP
PLATE. U.N.O.

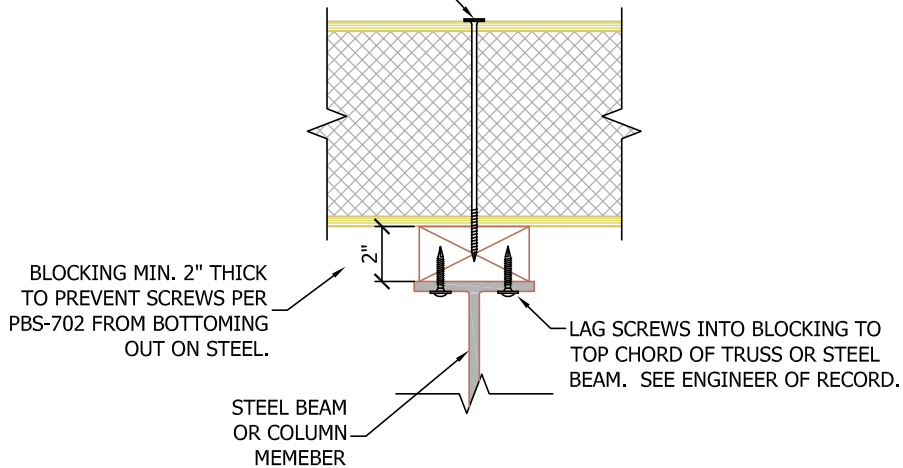

BLOCKING MIN. 2" THICK
TO PREVENT SCREWS PER
PBS-702 FROM BOTTOMING
OUT ON STEEL.

LAG SCREWS INTO BLOCKING TO
TOP CHORD OF TRUSS OR STEEL
BEAM. SEE ENGINEER OF RECORD.

STEEL BEAM
OR COLUMN
MEMEBER

STRUCTURAL SUPPORT TO PROVIDE 1 1/2" MIN.
BEARING FOR SIP

N.T.S.

Rev: 12/10/2021

PBS-600A-C

**SIP BEARING CONDITIONS
CONTINUOUS SIP**



OPTION D:

SIP SCREWS PER
PBS-100D W/ FULL
THREAD PENETRATION
INTO STEEL. U.N.O.

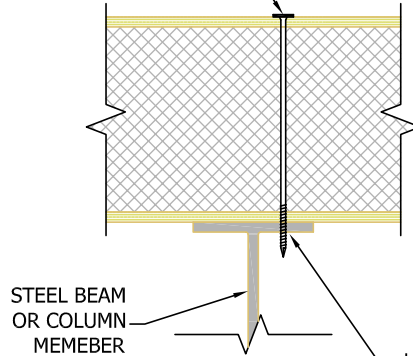

USE SELF TAPPING SIP SCREWS.
REFERENCE TECHNICAL BULLETIN D-15

STRUCTURAL SUPPORT TO PROVIDE 1 1/2" MIN.
BEARING FOR SIP

OPTION E:

SIP SCREWS PER
PBS-100D W/ 1" MIN
PENETRATION INTO TOP
PLATE. U.N.O.

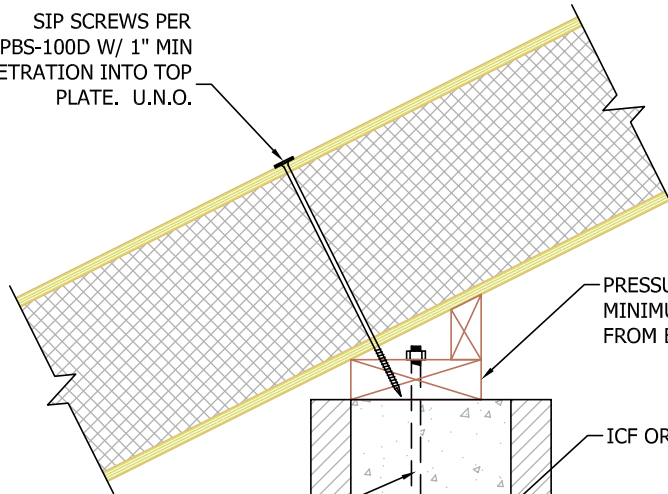

PRESSURE TREATED TOP PLATE
MINIMUM 2" THICK TO PREVENT SCREWS
FROM BOTTOMING OUT ON CONCRETE.

ICF OR CONCRETE WALL

ANCHOR BOLTS AS
REQUIRED BY CODE U.N.O.
IN SHEAR WALL SCHEDULE.

STRUCTURAL SUPPORT TO PROVIDE 1 1/2" MIN.
BEARING FOR SIP

N.T.S.

Rev: 9/19/2022

PBS-600D-E

**SIP BEARING CONDITIONS
CONTINUOUS SIP**



OPTION F:

SIP SCREWS PER PBS-100D
W/ 1" MIN PENETRATION
INTO BLOCKING U.N.O.

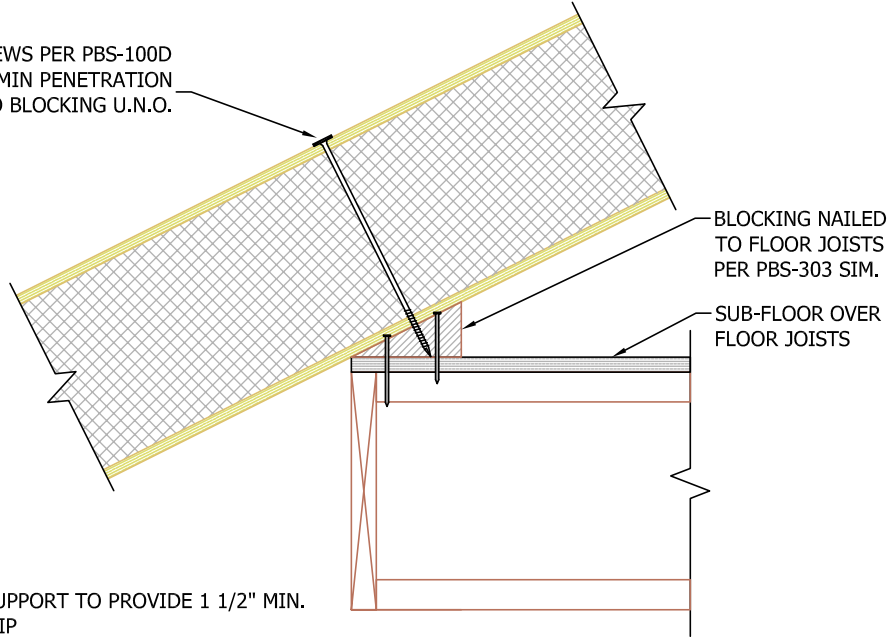

STRUCTURAL SUPPORT TO PROVIDE 1 1/2" MIN. BEARING FOR SIP

OPTION G:

SIP SCREWS PER
PBS-100D W/ 1" MIN
PENETRATION INTO
PLATE. U.N.O.

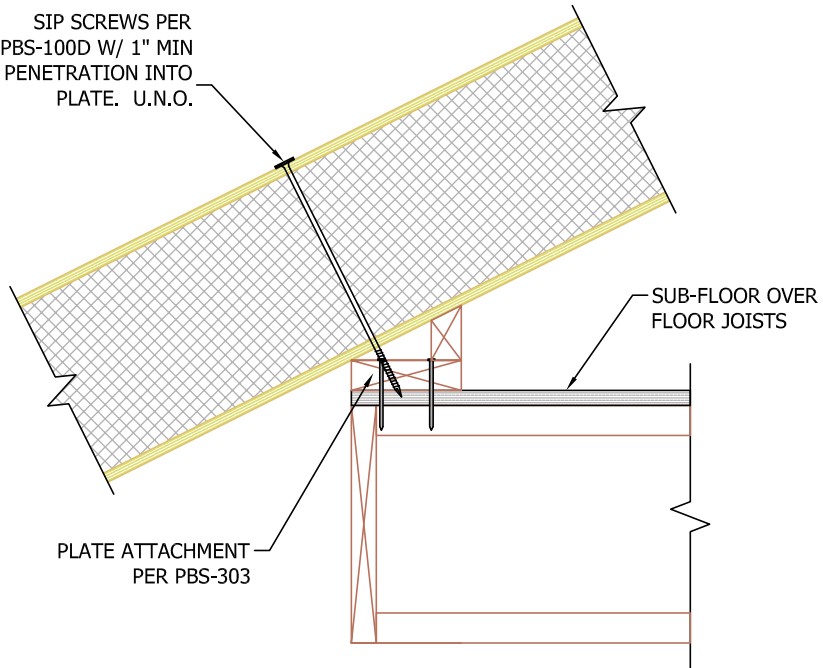

STRUCTURAL SUPPORT TO PROVIDE 1 1/2" MIN. BEARING FOR SIP

N.T.S.

Rev: 9/23/2022

PBS-600F-G

**SIP BEARING CONDITIONS
CONTINUOUS SIP**



OPTION H:

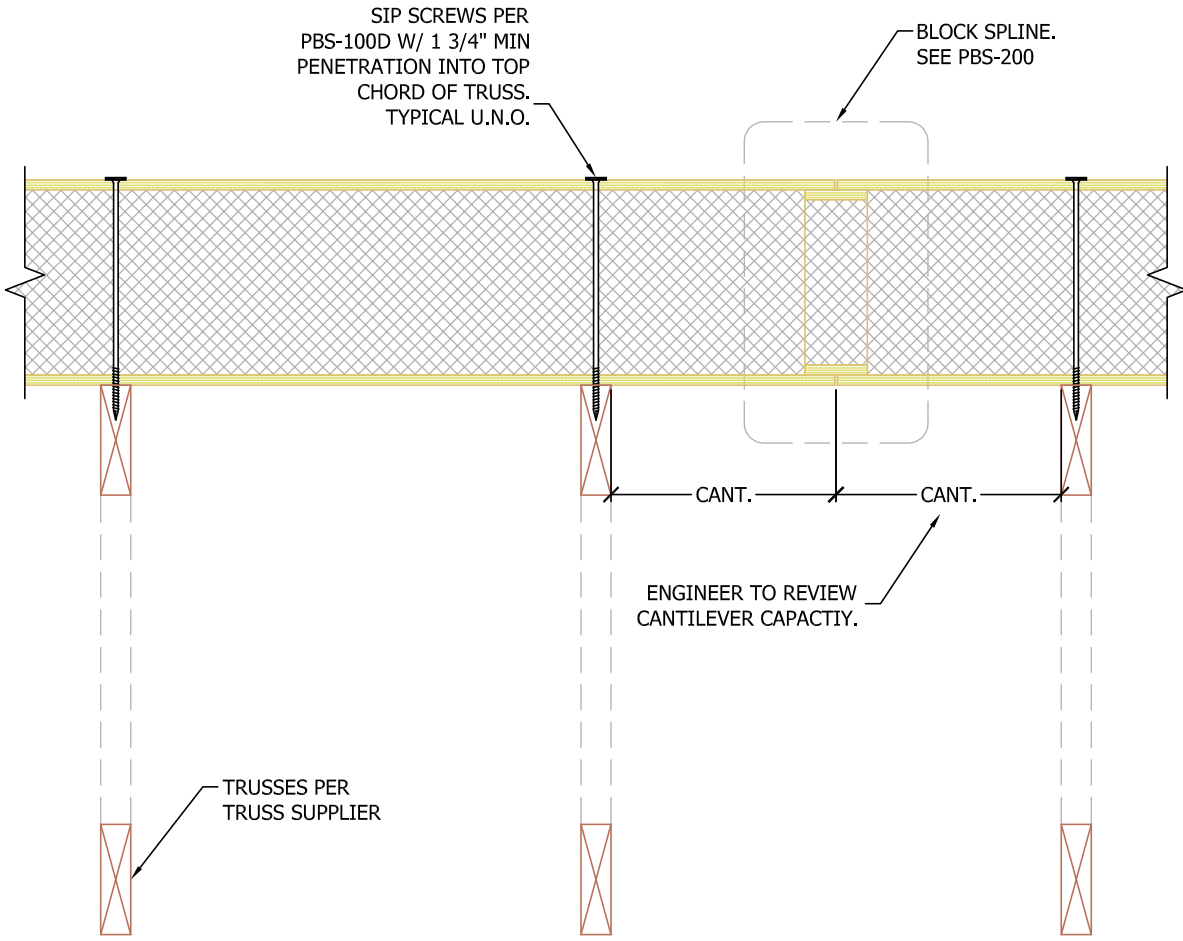

N.T.S.

Rev: 9/19/2022

PBS-600H

SIP BEARING CONDITIONS
CONTINUOUS SIP



OPTION A:

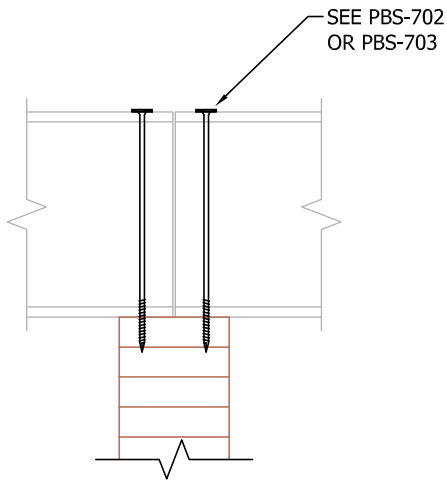

STRUCTURAL SUPPORT MIN. 3" WIDE TO PROVIDE 1 1/2" MIN. BEARING FOR EACH SIP

OPTION B:

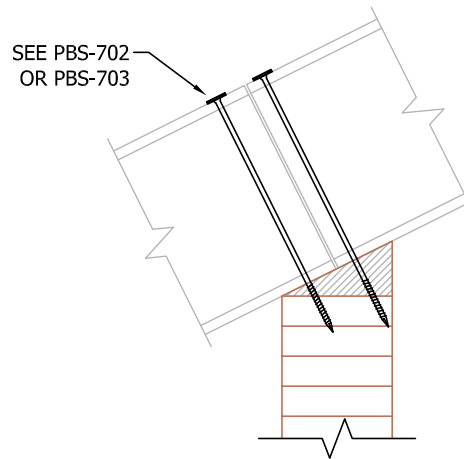

STRUCTURAL SUPPORT MIN. 3" WIDE TO PROVIDE 1 1/2" MIN. BEARING FOR EACH SIP

OPTION C:

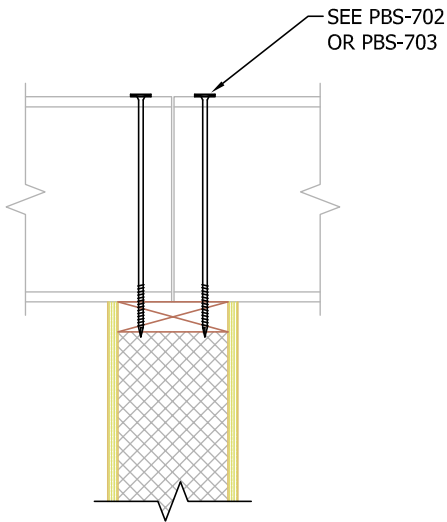

STRUCTURAL SUPPORT MIN. 3" WIDE TO PROVIDE 1 1/2" MIN. BEARING FOR EACH SIP

N.T.S.

OPTION D:

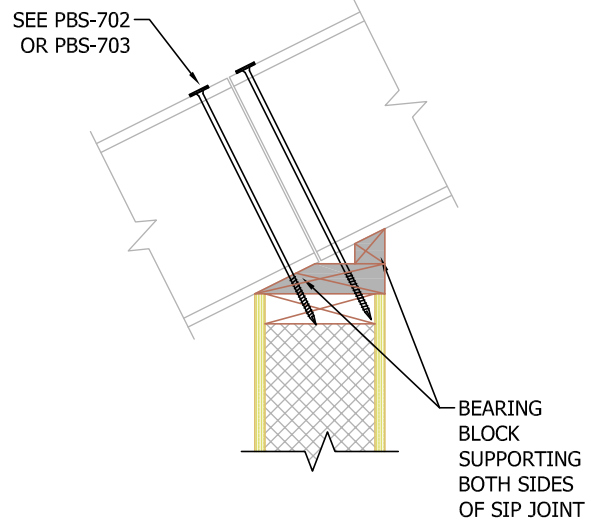

STRUCTURAL SUPPORT MIN. 3" WIDE TO PROVIDE 1 1/2" MIN. BEARING FOR EACH SIP

Rev: 1/18/2023

PBS-601A-D

**SIP BEARING CONDITIONS
SIP JOINT**



OPTION E:

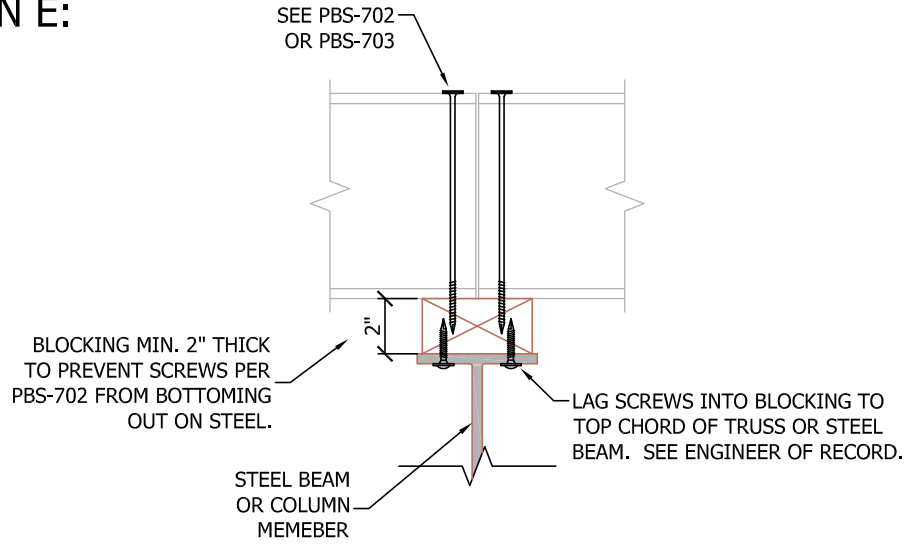

STRUCTURAL SUPPORT MIN. 3" WIDE TO PROVIDE
1 1/2" MIN. BEARING FOR EACH SIP

OPTION F:

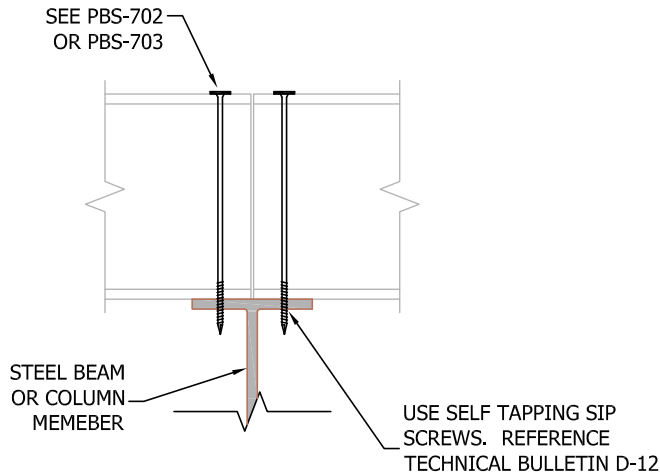

STRUCTURAL SUPPORT MIN. 3" WIDE TO PROVIDE
1 1/2" MIN. BEARING FOR EACH SIP

N.T.S.

Rev: 1/18/2023

PBS-601E-F

**SIP BEARING CONDITIONS
SIP JOINT**



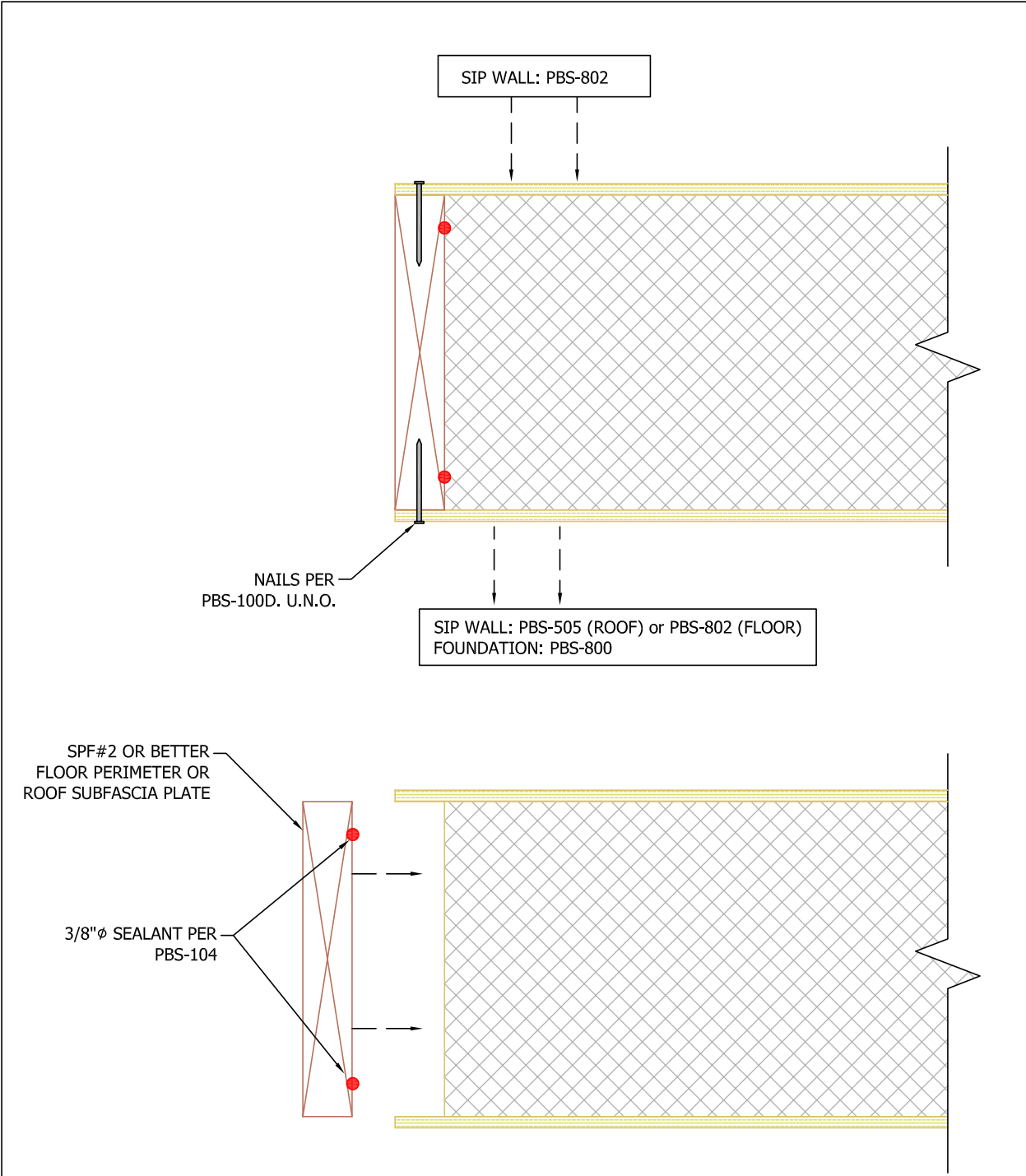

N.T.S.

Rev: 6/3/2021

PBS-700

SIP FLOOR/ROOF PLATE



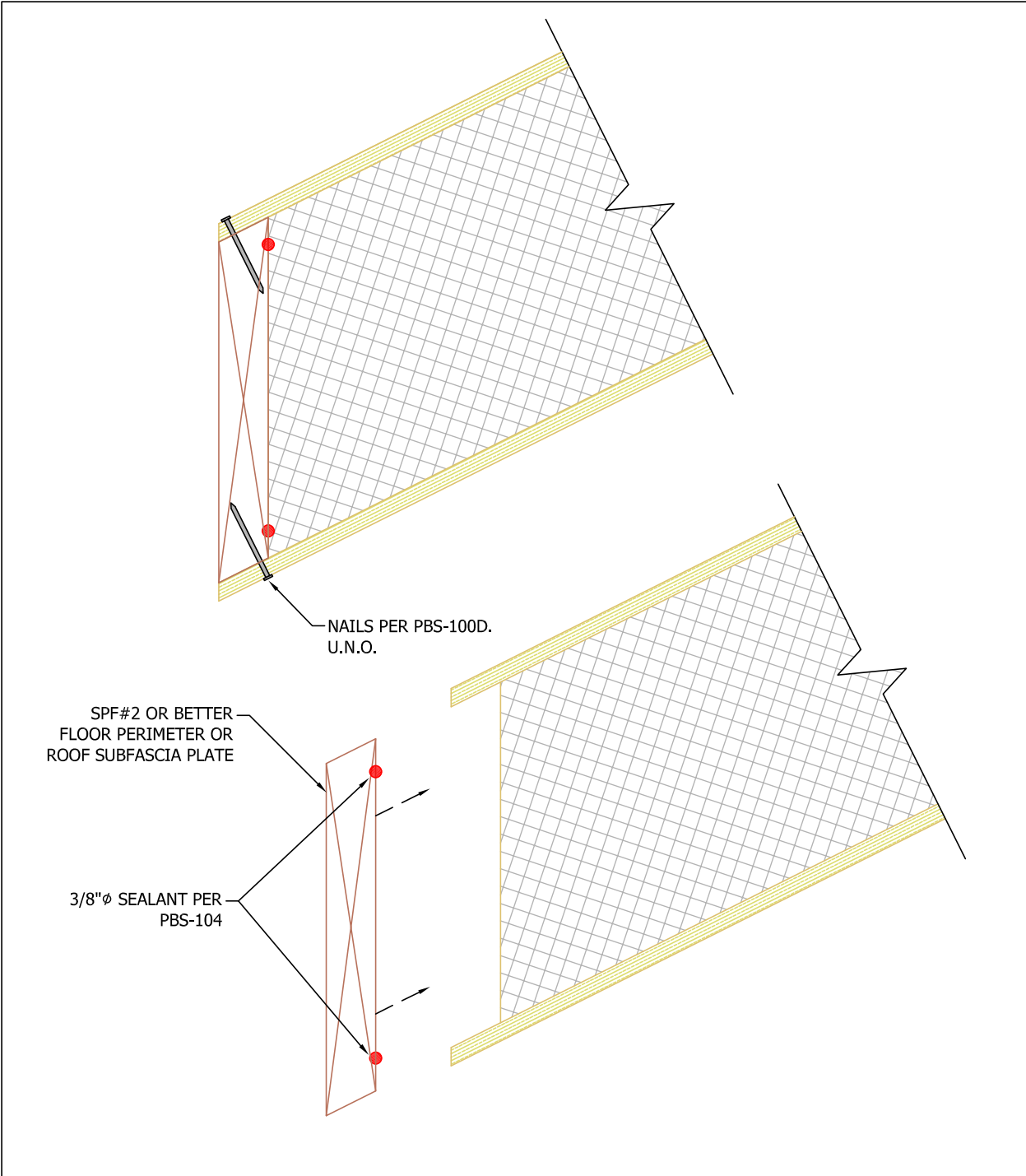

N.T.S.

Rev: 12/10/2021

PBS-701

BEVELED ROOF PLATE



SIP SCREWS PER
PBS-100D W/ 1" MIN
PENETRATION INTO
STRUCTURAL SUPPORT
U.N.O.

1/8" GAP

3/8"Ø SEALANT
PER PBS-104

18" SIP TAPE
PER PBS-105

SEE PBS-601 FOR SIP
BEARING OPTIONS

STRUCTURAL SUPPORT
MIN. 3" WIDE TO PROVIDE
1 1/2" MIN. BEARING FOR
EACH ROOF SIP

N.T.S.

Rev: 12/10/2021

PBS-702

FLUSH FOAM ABOVE BEARING



SIP SCREWS PER
PBS-100D W/ 1" MIN
PENETRATION INTO
STRUCTURAL SUPPORT
U.N.O.

1/8" GAP

NAILS PER PBS-100D.
U.N.O.

3/8"φ SEALANT PER
PBS-104

18" SIP TAPE
PER PBS-105

SEE PBS-601 FOR SIP
BEARING OPTIONS

STRUCTURAL SUPPORT
MIN. 3" WIDE TO PROVIDE
1 1/2" MIN. BEARING ON
EACH SIDE OF SIP JOINT

N.T.S.

Rev: 7/18/2022

PBS-703

BOX/BLOCK SPLINE ABOVE BEARING



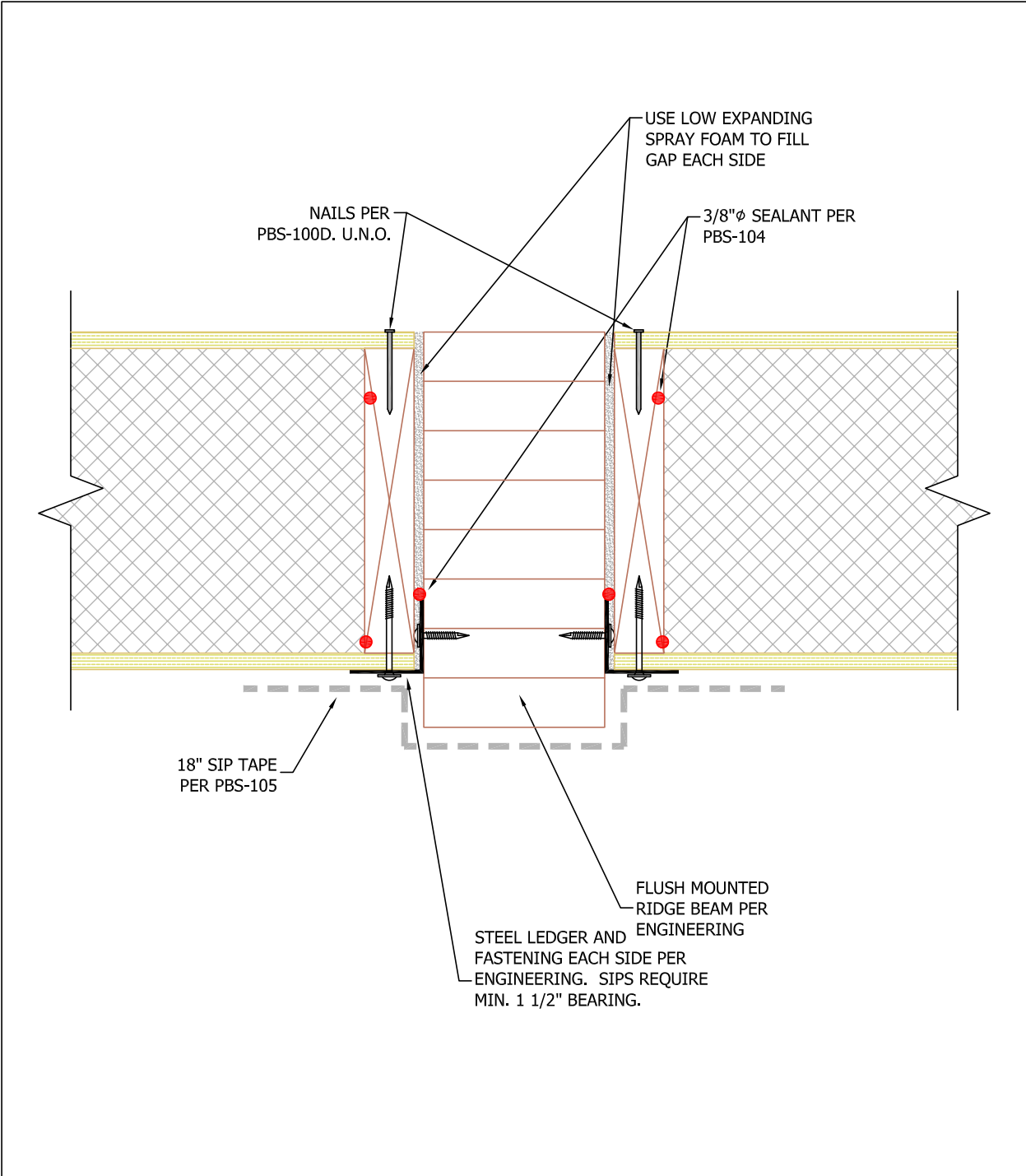

N.T.S.

Rev: 9/19/2022

<p>PBS-704</p>	<p>ROOF BEAM FLUSH MOUNTED BEAM</p>	
----------------	---	---

NOTE:
SEE PBS-600 FOR ALTERNATE SIP BEARING CONDITIONS

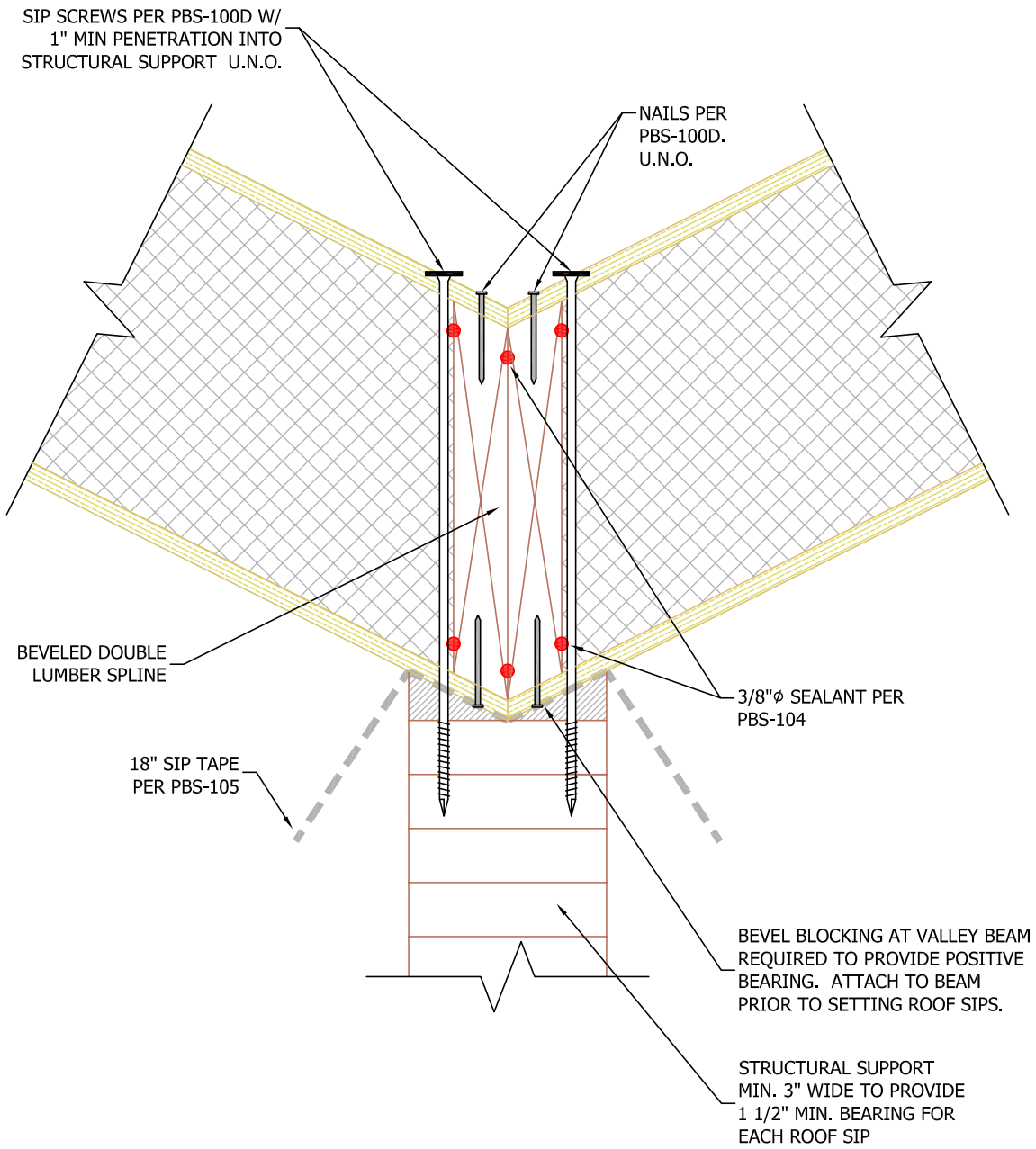

N.T.S.

Rev: 2/16/2023

PBS-705

**ROOF VALLEY
BEVEL CUT**



NOTES:

1. SEE PBS-600 FOR ALTERNATE SIP BEARING CONDITIONS
2. THE MAXIMUM VERTICAL REACTION SHALL NOT EXCEED 400 PLF (ASD) FROM EITHER ROOF SIP, OTHERWISE USE DETAIL PBS-705

SIP SCREWS PER PBS-100D W/
1" MIN PENETRATION INTO
STRUCTURAL SUPPORT U.N.O.

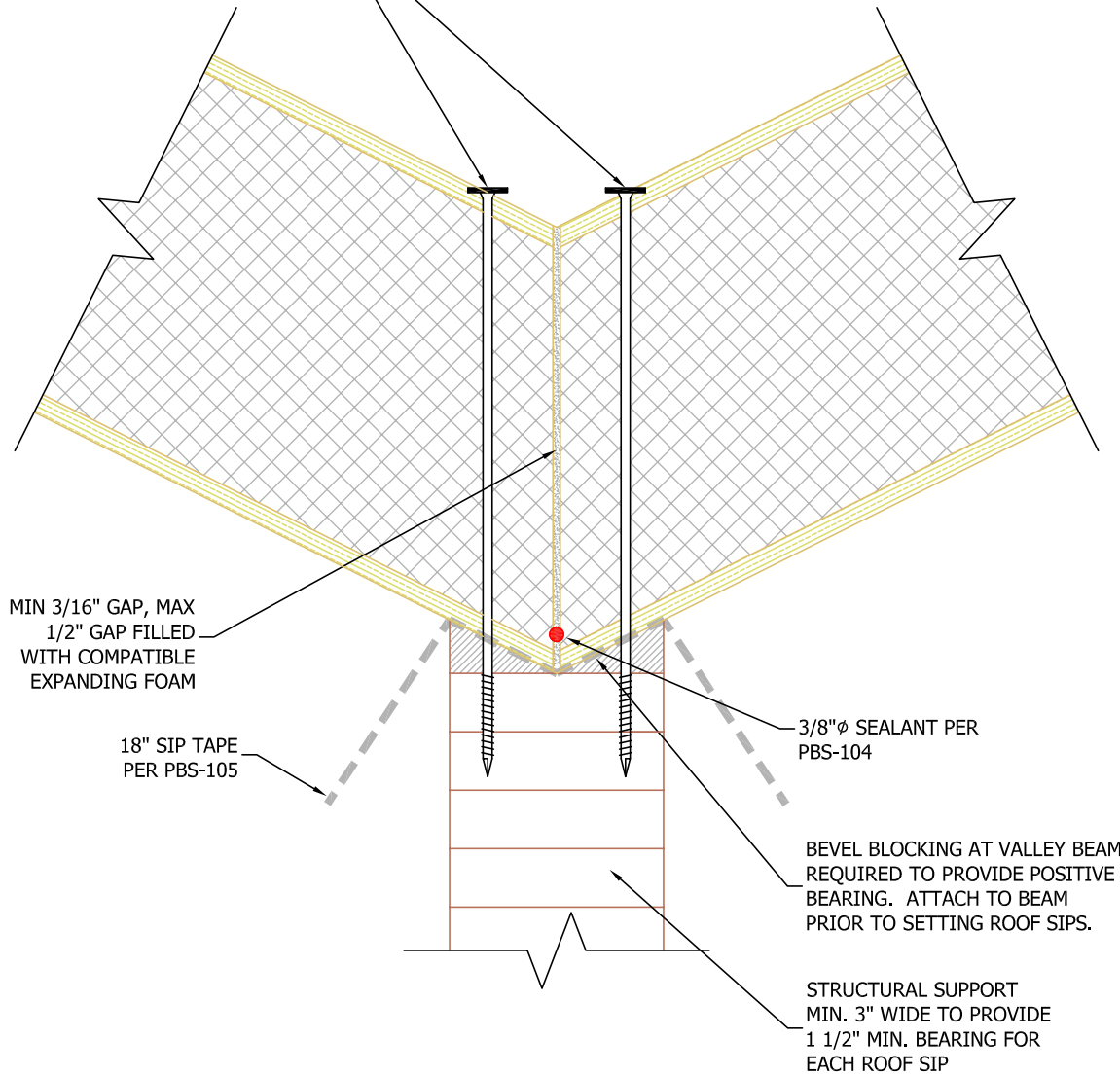

MIN 3/16" GAP, MAX
1/2" GAP FILLED
WITH COMPATIBLE
EXPANDING FOAM

18" SIP TAPE
PER PBS-105

3/8" ϕ SEALANT PER
PBS-104

BEVEL BLOCKING AT VALLEY BEAM
REQUIRED TO PROVIDE POSITIVE
BEARING. ATTACH TO BEAM
PRIOR TO SETTING ROOF SIPS.

STRUCTURAL SUPPORT
MIN. 3" WIDE TO PROVIDE
1 1/2" MIN. BEARING FOR
EACH ROOF SIP

N.T.S.

Rev: 12/10/2021

PBS-706

**ROOF VALLEY FLUSH FOAM
BEVEL CUT**



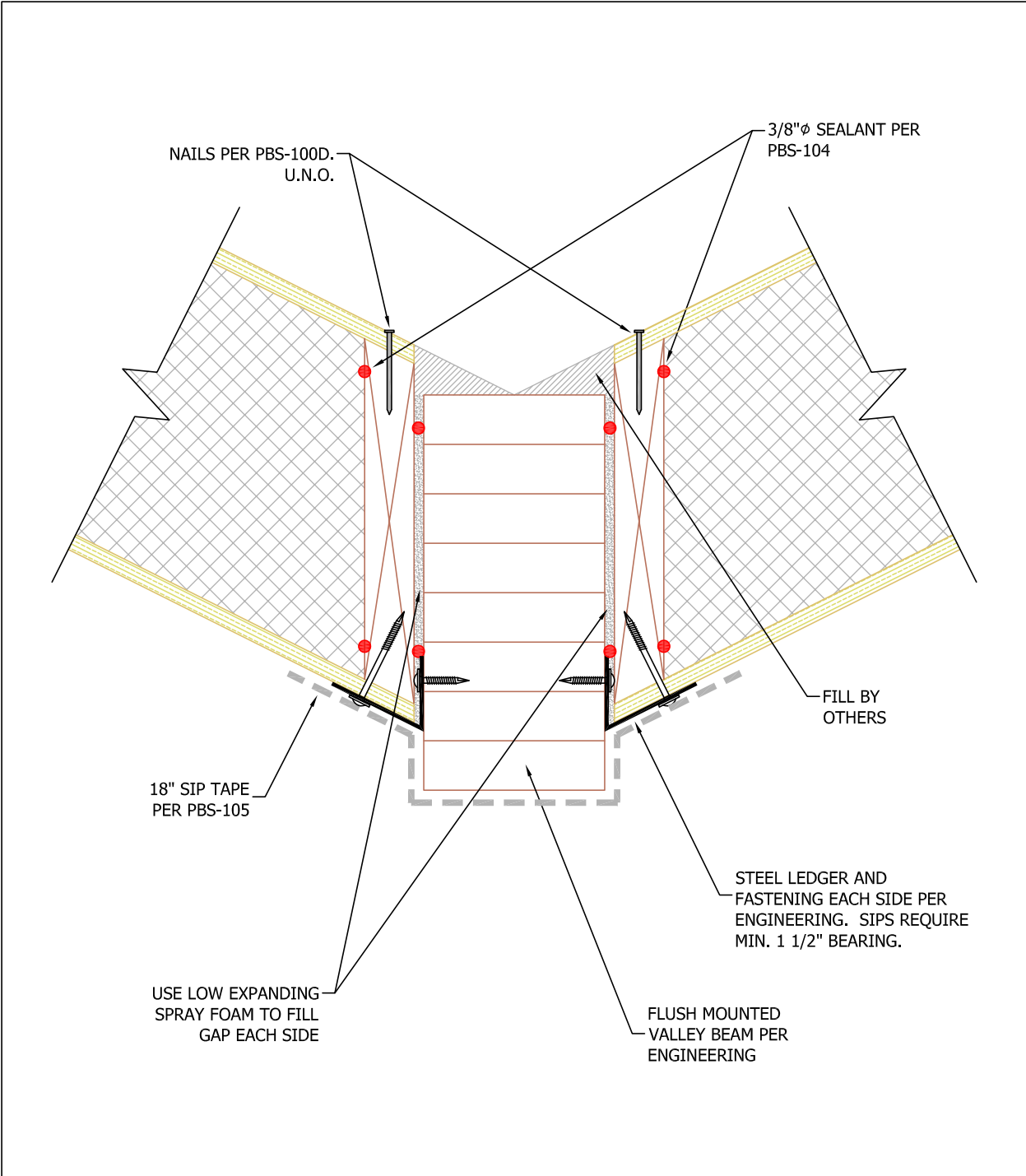

N.T.S.

Rev: 9/19/2022

<p>PBS-707</p>	<p>ROOF VALLEY FLUSH MOUNTED VALLEY BEAM</p>	
----------------	--	---

NOTE:
SEE PBS-600 FOR ALTERNATE SIP BEARING CONDITIONS

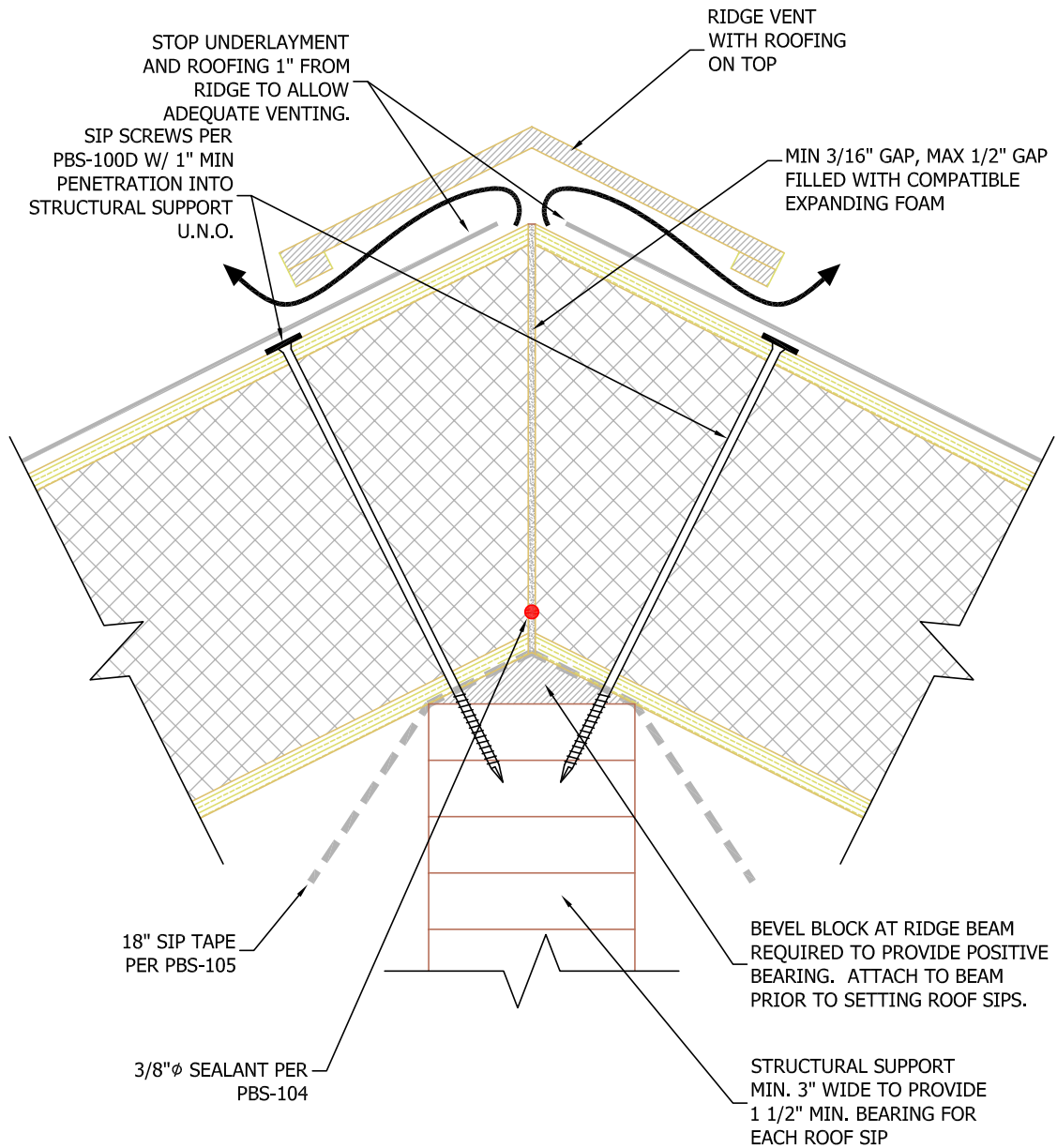

N.T.S.

Rev: 3/31/2022

PBS-708

ROOF RIDGE / HIP FLUSH FOAM
BEVEL CUT



NOTE:
SEE PBS-600 FOR ALTERNATE SIP BEARING CONDITIONS

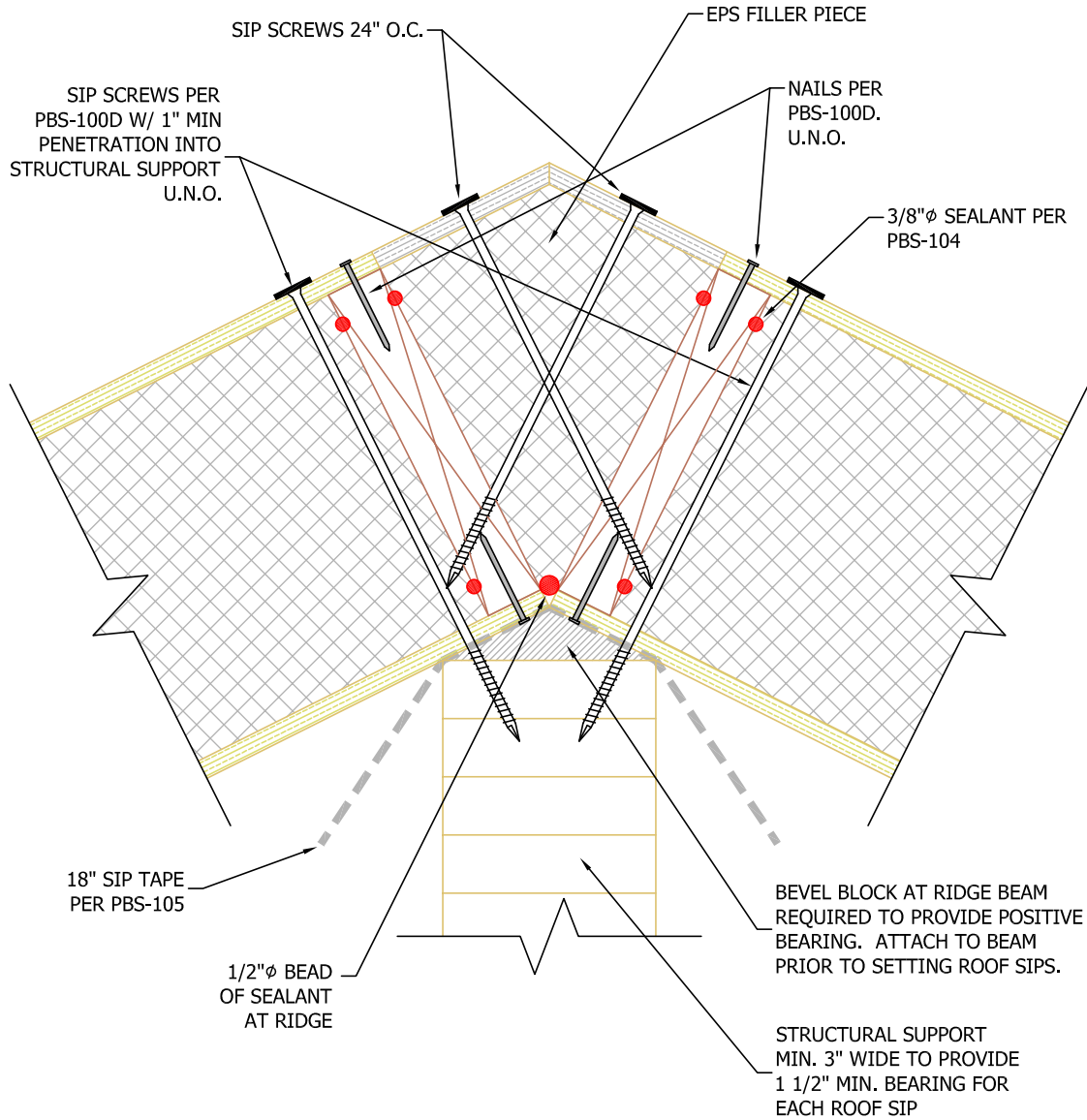

N.T.S.

Rev: 2/16/2023

PBS-709

**ROOF RIDGE
RIDGE CAP**



NOTE:
SEE PBS-600 FOR ALTERNATE SIP BEARING CONDITIONS

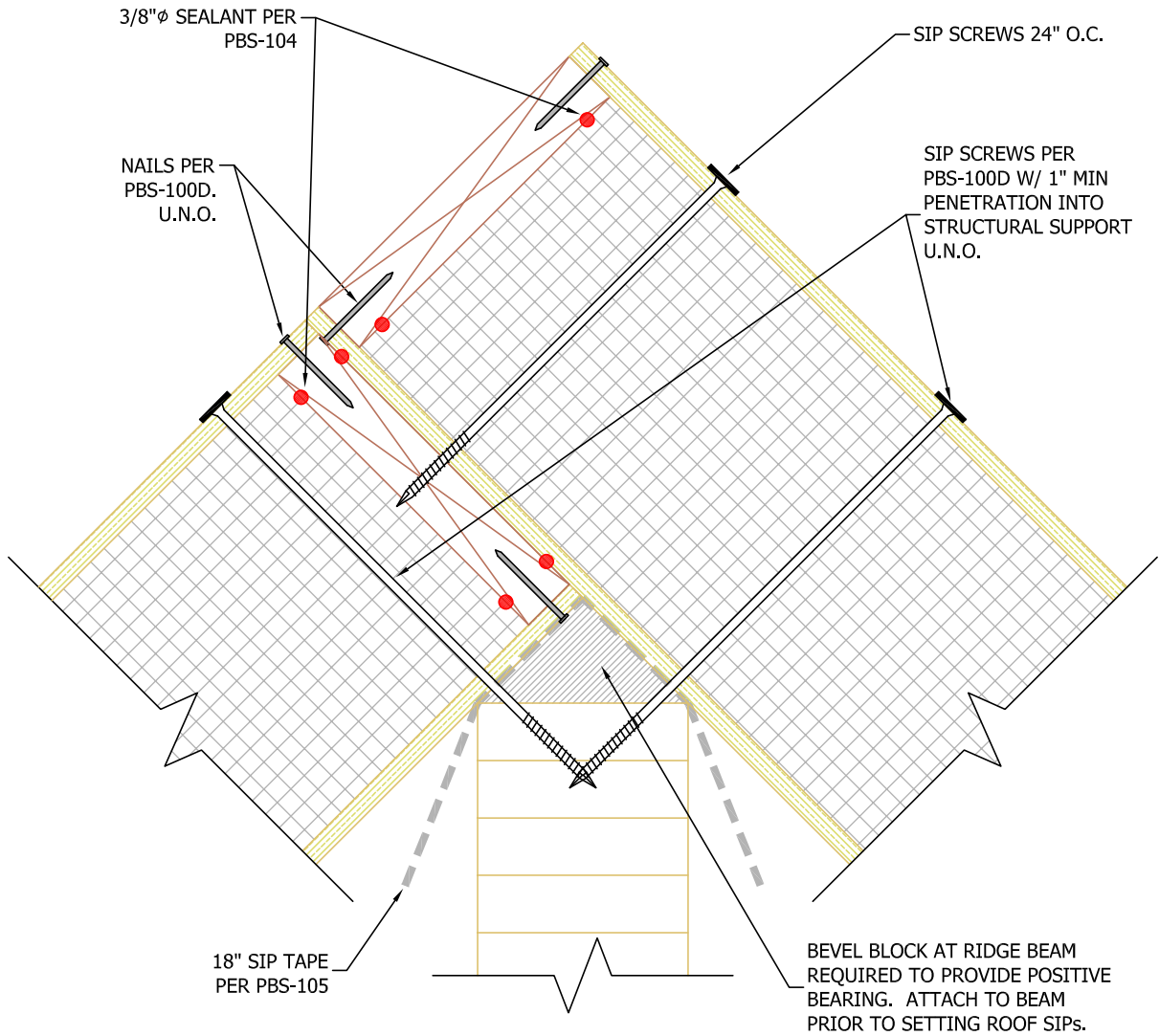

N.T.S.

Rev: 12/10/2021

PBS-710

ROOF RIDGE
OVERLAP



NOTE:

THIS DETAIL IS ONLY PERMITTED IN SITUATIONS WHERE THE SIP IS SPANNING PARALLEL TO THE RIDGE. E.G. BEARING ON TRUSSES, OR RAFTERS.

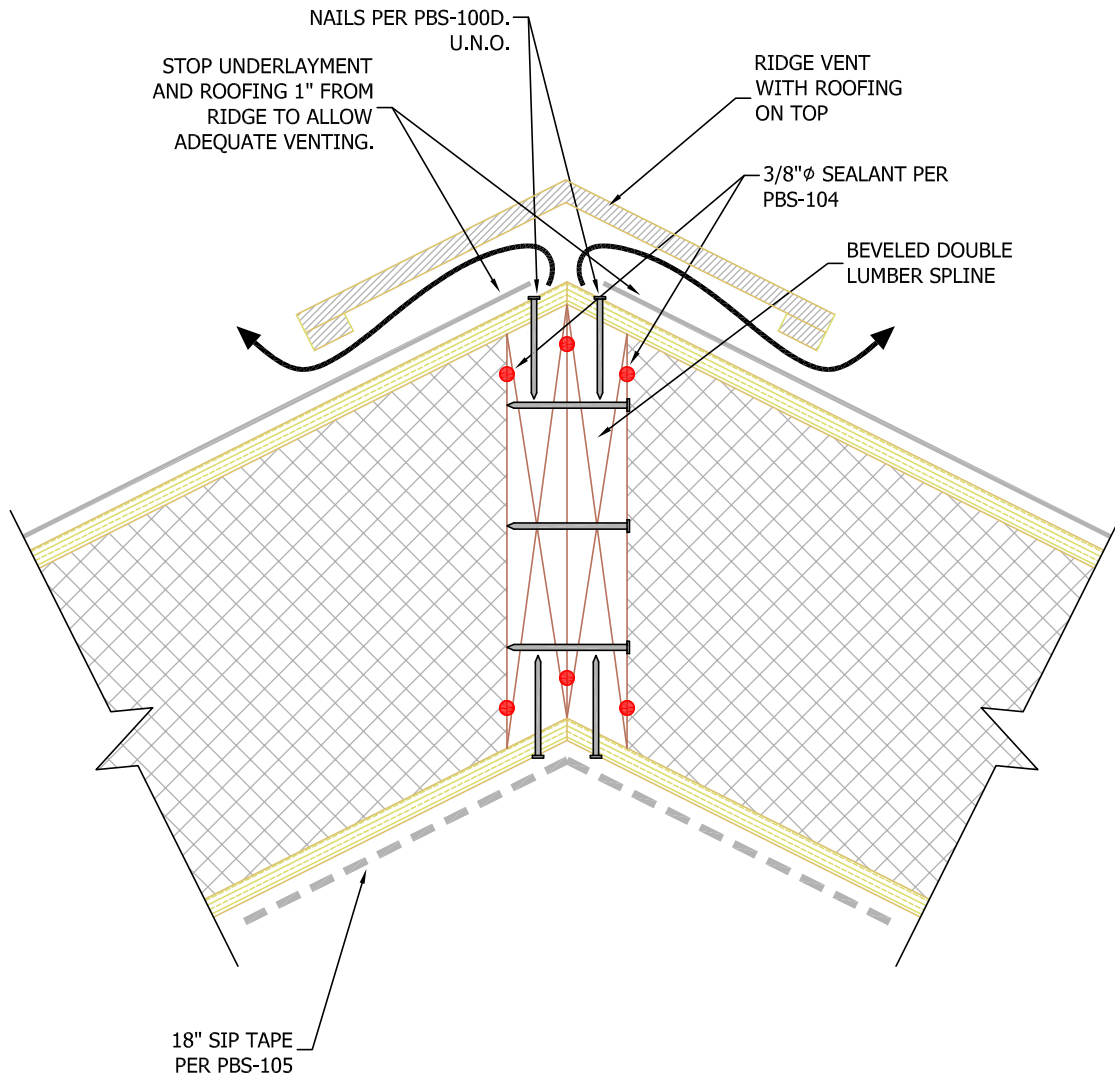

N.T.S.

Rev: 2/16/2023

PBS-711

**ROOF RIDGE
SIPS SPANNING PARALLEL TO RIDGE**



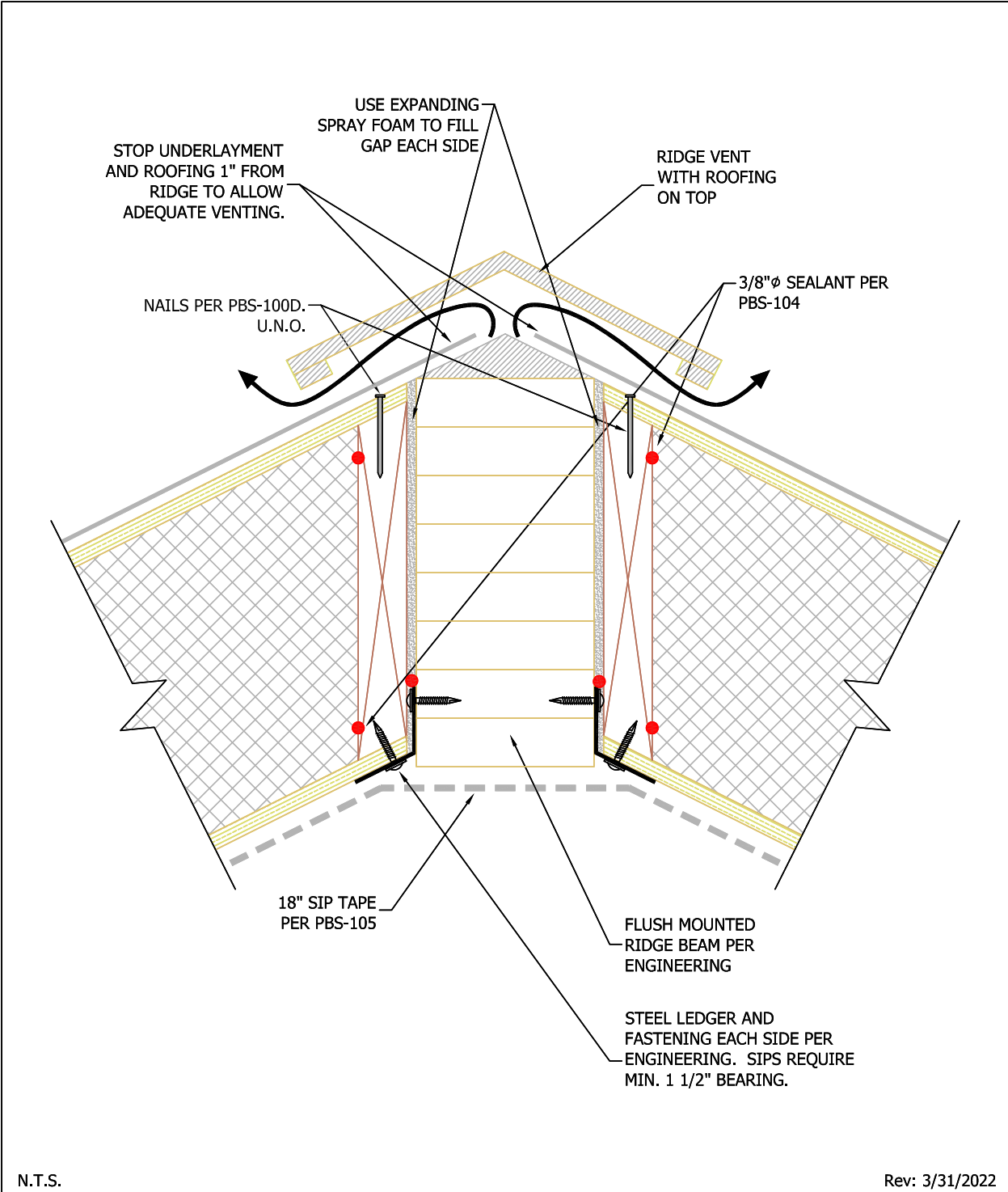

<p>PBS-712</p>	<p>ROOF RIDGE FLUSH MOUNTED RIDGE BEAM</p>	<p>PREMIER SIPS</p>
----------------	--	----------------------------

NOTE:

CANTILEVER SPAN PER ENGINEER.

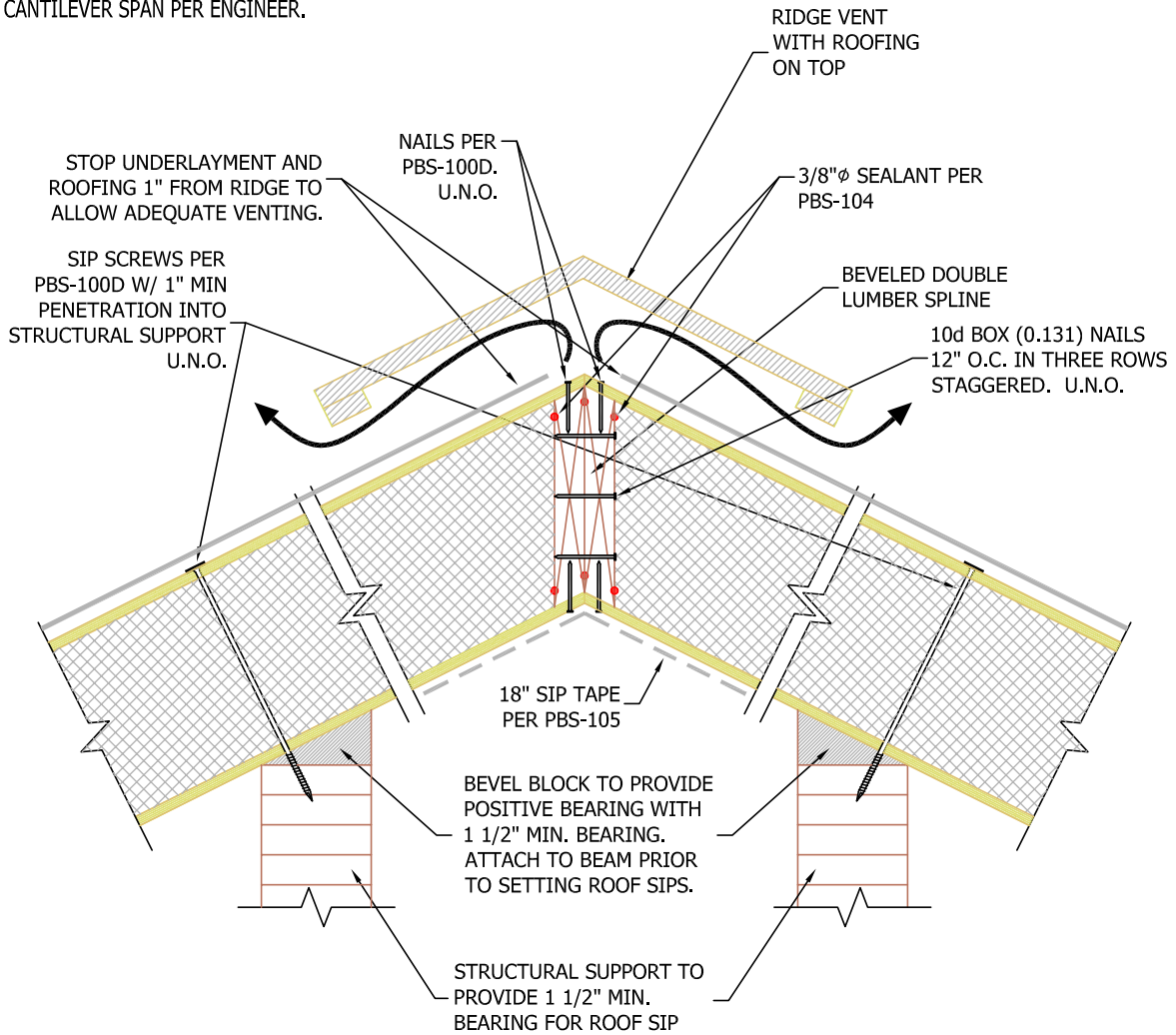

N.T.S.

Rev: 2/16/2023

PBS-713

**ROOF RIDGE
CANTILEVERED SIP**



NOTE:
SEE PBS-600 FOR ALTERNATE SIP BEARING CONDITIONS

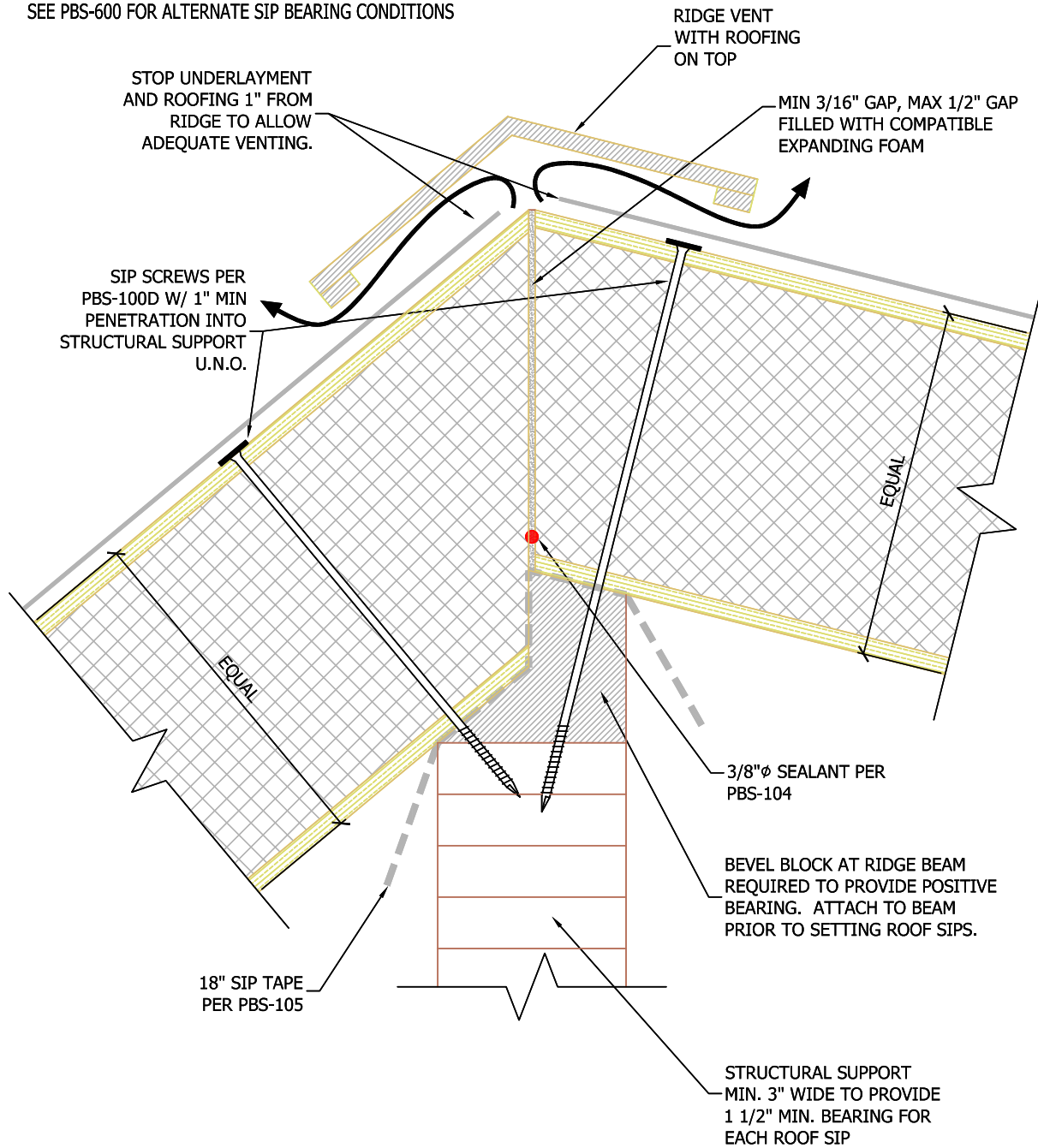

N.T.S.

Rev: 3/31/2022

PBS-714

**ROOF RIDGE FLUSH FOAM
PLUMB CUT AT DIFFERENT PITCHES**



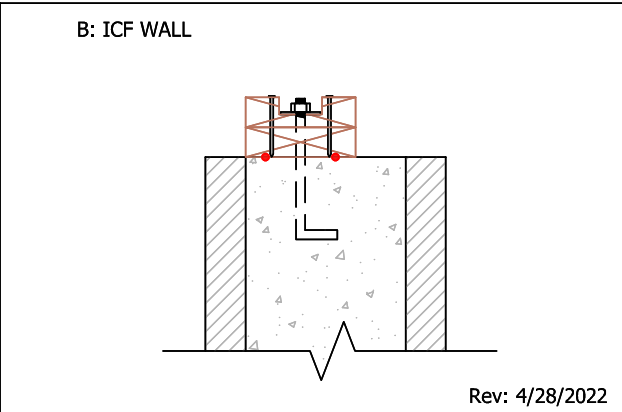
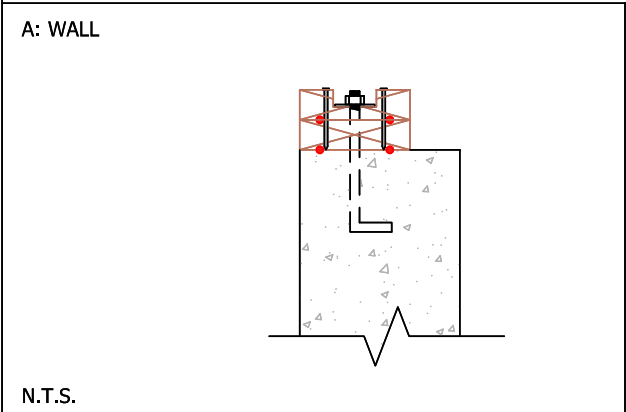
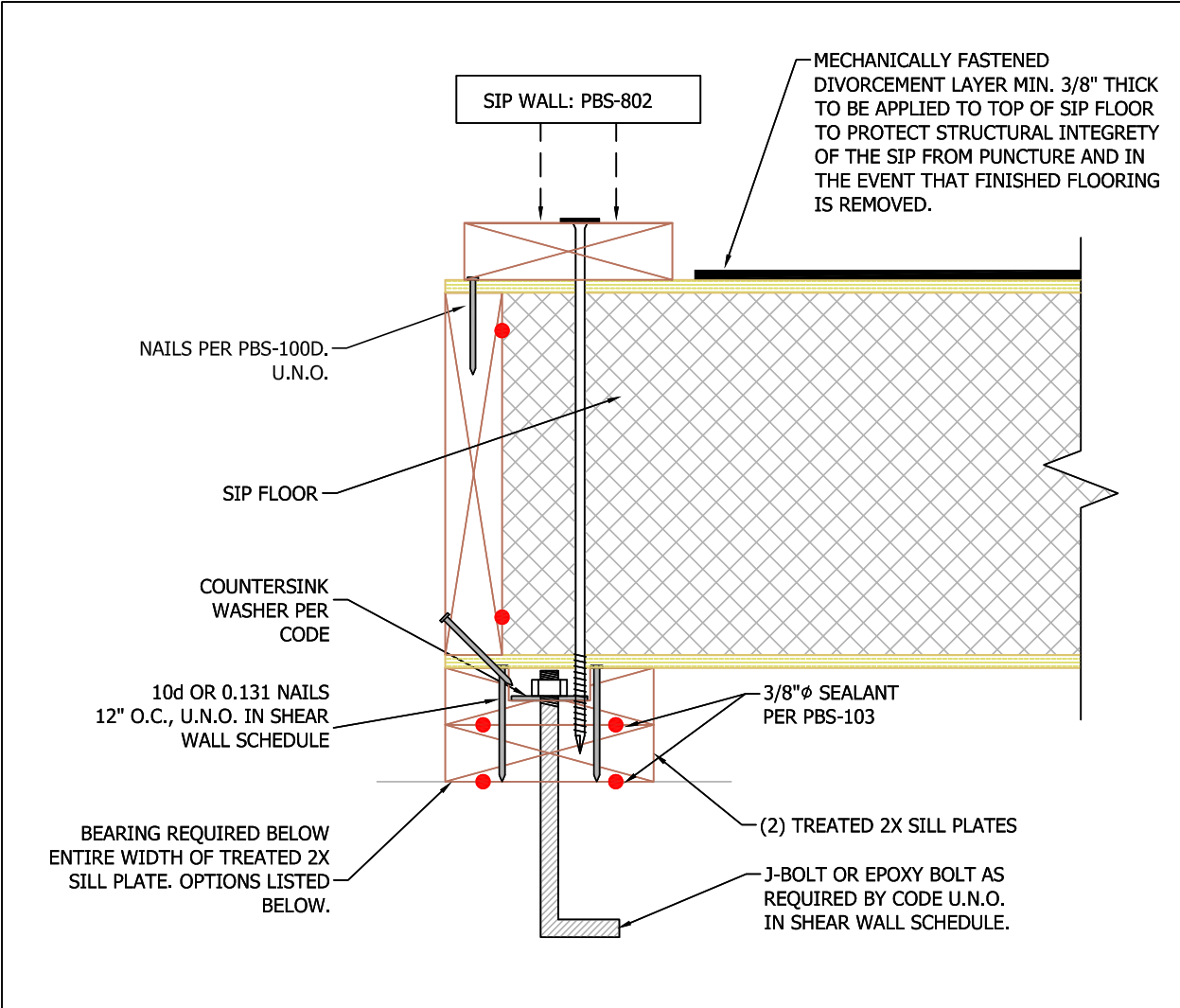

<p>PBS-800</p>	<p>CAPILLARY 2X SILL BOTTOM PLATE SIP FLOOR CONNECTION</p>	
-----------------------	---	--

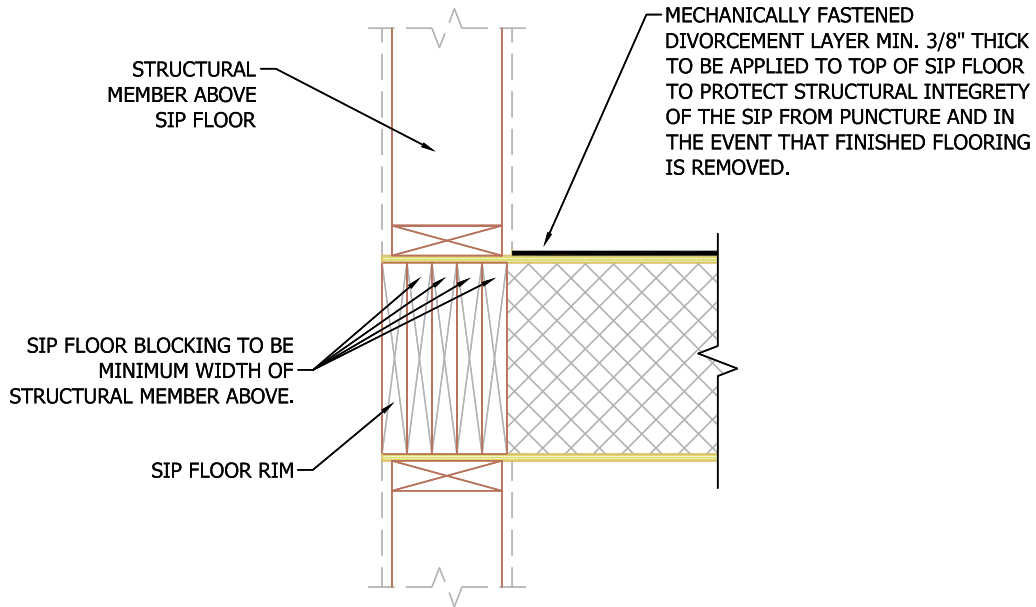
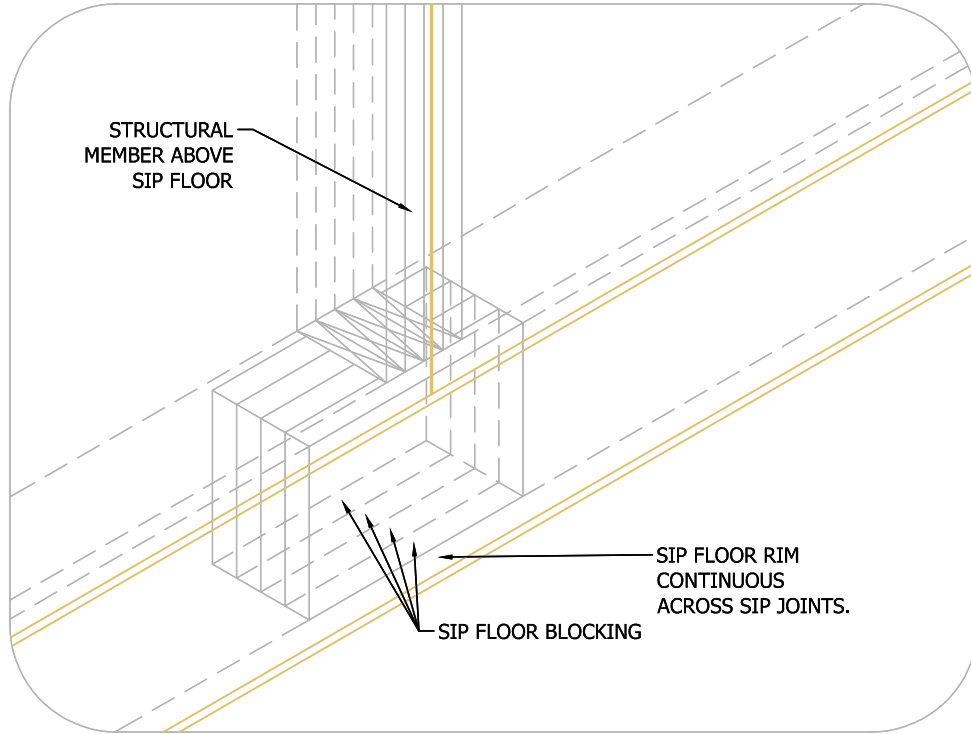

N.T.S.

Rev: 3/31/2022

PBS-801

SIP FLOOR POINTLOAD BLOCKING



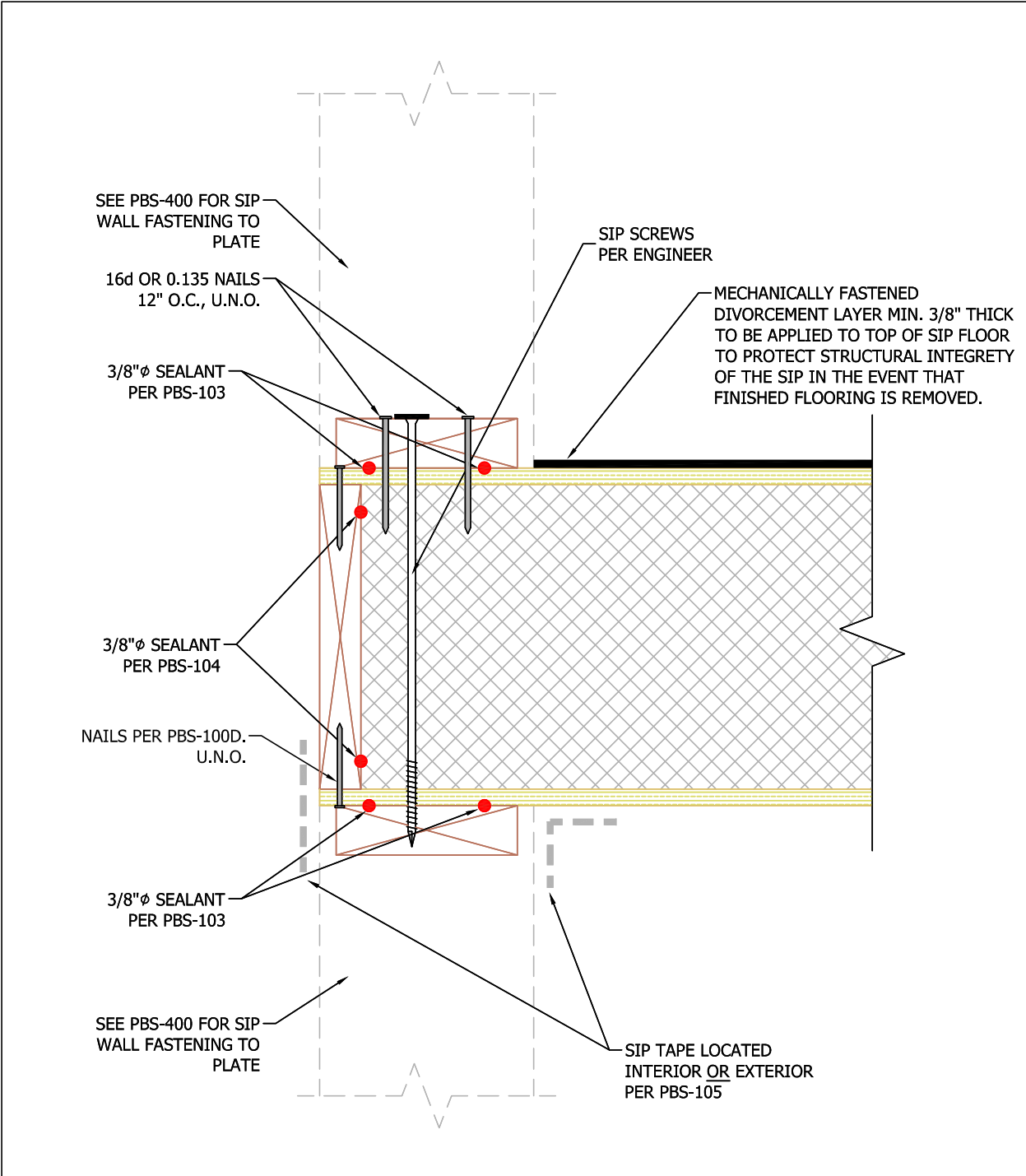

N.T.S.

Rev: 7/19/2022

PBS -802

SIP FLOOR PLATFORM FRAMING





Website: premierlips.com

Toll Free: 800-275-7086



A PRODUCT OF

PREMIER
BUILDING SYSTEMS

FASTER. STRONGER. GREENER.™